

BONENG

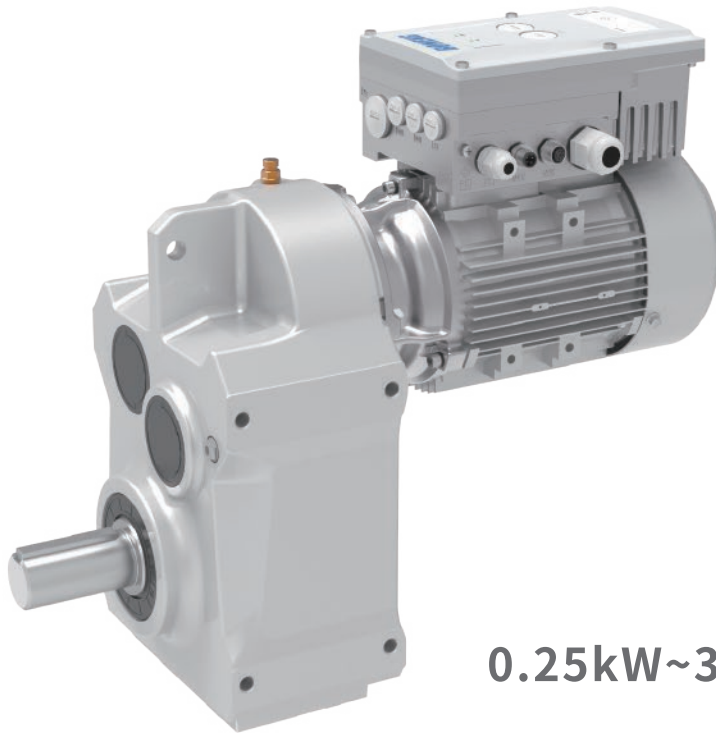

0.25kW~3kW

F平行轴齿轮马达
变频驱动一体机

F Parallel Shaft
Gearmotor Variable
Frequency Drive
All-in-one

Edit date 04/2023
Selection Catalogue: C05.0052-CN/EN

Boneng Transmission

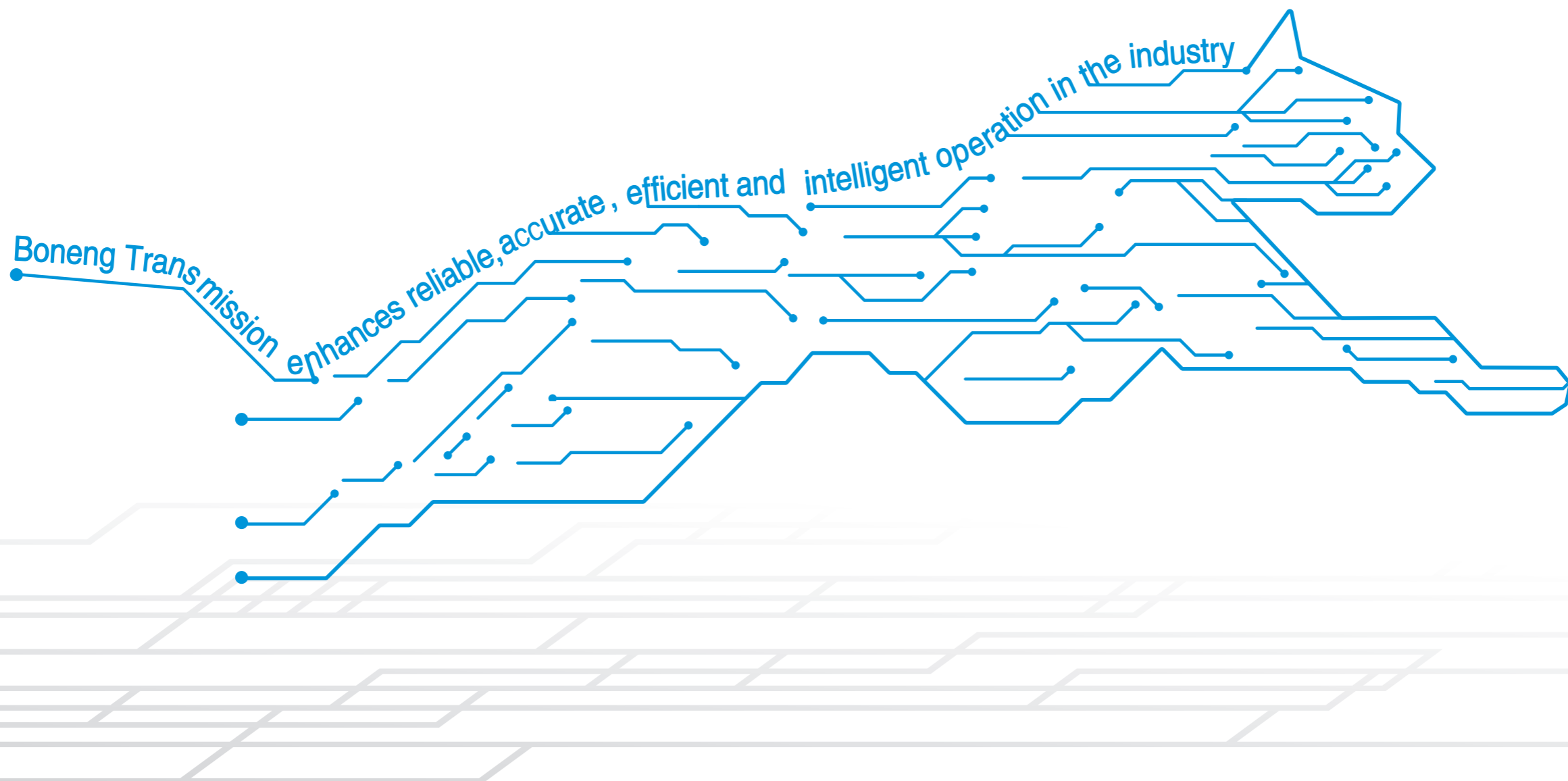

控制器/驱动器/马达/
齿轮马达/齿轮箱

Controller/ Drive/ Motor/
Gearmotor/ Gearbox

选型注意事项:

- ◆ 结构示意图、外形图及其他附图只属范例，无严格比例要求。（未注尺寸单位均为mm）。
- ◆ 所注重量仅为平均值，并不具有约束力。
- ◆ 注油量只作为参考值，实际注油量应以油镜上的标记为准。

⚠ 使用注意事项

- ◆ 为防止意外事故发生，所有旋转部件均按照使用者所在国家和地区的安全规范由购置方加罩保护。
- ◆ 试车之前必须认真阅读使用说明书。
- ◆ 齿轮马达在供货时已处于准运行状态，运行前需加注润滑油。
- ◆ 齿轮马达应由熟悉相关安全要求的专业人员安装；安装时必须有安全装置以防止事故发生，安装位置必须符合规定。

Note:

- ◆ The structure scheme, appearance diagram and other attached diagrams in sample are examples, there is no strict proportion requirement. (The unmarked dimension units are mm).
- ◆ The marked weight is average value, it has no constraint force.
- ◆ The marked oil quantity in sample is only reference value, actual oil filling quantity should be the same with the mark on oil immersion lens.

⚠ You must confirm to the following instructions

- ◆ To prevent accidents, all the rotation parts are added with protective covers according to the safety regulations of the nation and region.
- ◆ Before debugging, you should carefully read instruction book.
- ◆ Gearmotor is on running-permission status when delivered, you should add lubrication oil before putting it into running.
- ◆ The gearmotor should be installed by technical staffs who could be familiar with corresponding security requirements. Security device should be required for preventing from accidents while installation position must be satisfied with regulations.

目录

Contents

01.概述	01	01.Overview	01
02.产品特性	01	02.Characteristics	01
03.优势特点	04	03.Advantages	04
04.型号表示方法	05	04.Type Designation	05
05.传动能力表	07	05.Transmission Capacity	07
06.外形尺寸图	15	06.Dimensions	15
07.允许的输出轴径向力表	29	07.Permissible Radial Force of Output Shaft	29
08.被驱动轴推荐尺寸	30	08.Recommended Dimensions for Driven Equipment Shaft	30
09.轴端中心孔尺寸	32	09.Dimensions of Shaft End Centre Hole	32
10.平键与键槽的尺寸	33	10.Dimension of Parallel Key and Keyway	33
11.可选附件和指定配置	34	11.Accessories and Specific Configuration	34
12.润滑油	35	12.Oil	35
13.重量表	35	13.Weight	35

1.概述

齿轮马达变频驱动一体机是基于分布式应用的齿轮马达、驱动器一体式产品，搭配全封闭自扇冷却三相交流异步马达，设计生产符合ISO、IEC、GB等相关标准的要求。适用于连续工作制(S1)、恒转速或一定速度范围内的变频调速应用，同时也满足大部分断续工作方式(S2-S10)。

该一体机系统专门针对输送带、分拣系统、行李和货物运输系统、仓库和配送物流、邮件分拣以及包裹配送等应用中的节能和成本效益水平运动进行了优化。可广泛应用于多机水平输送等行业，以及对防护等级有较高要求的电气传动场合。

2.产品特性

2.1.技术特性

- ◆ 颜色：银色RAL9006
- ◆ 马达额定功率：0.25kW~3kW；
- ◆ 马达极数：4；
- ◆ 马达效率：达到GB18613-2020标准能效等级3级，且满足IEC 60034-30标准中的IE2和IE3效率等级；
- ◆ 马达防护等级：防护等级为IP55；
- ◆ 马达绝缘等级：绝缘系统按155°C (F) 温度等级设计，按130°C (B) 温度等级考核；
- ◆ 马达冷却方式：马达标准冷却方式为IC411自扇冷却。
- ◆ 支持SVC(开环矢量)控制、VF控制
- ◆ 可实现速度控制与转矩控制
- ◆ 支持Modbus通讯、EtherCAT通讯
- ◆ 支持本地上位机连接

2.2.运行环境

- ◆ 高度不超过海拔1000m；
- ◆ 允许的环境温度在-20°C ~ 40°C；
- ◆ 所允许的相对湿度：
 - 20°C ≤ T ≤ 20°C：100%
 - 20°C < T ≤ 30°C：95%
 - 30°C < T ≤ 40°C：55%

1.Overview

Gearmotor variable frequency drive all-in-one is based on distributed application and equipped with totally enclosed fan cooled three-phase asynchronous motor. Its design and production meet the requirements of ISO, IEC, GB and other related standards. The integrated machine is applicable for continuous running duty (S1), constant speed and variable frequency speed control within a specific speed range. Also, it can meet most short-time duty (S2-S10).

The integrated machine system is optimized for energy conservation and cost performance in the field of conveyor belt, automatic sorting systems, baggage and cargo system, warehouse and distribution logistics, mail sorting, parcel delivery and other objects. It is widely used in multi-machine horizontal conveying and other industries, as well as electrical transmission occasions with higher requirements for protection levels.

2.Characteristics

2.1.Technical characteristics

- ◆ Motor color: silver RAL9006;
- ◆ Rated power: 0.25kW~3kW;
- ◆ Poles of motor:4;
- ◆ Motor efficiency: meet Grade 3 according to GB18613-2020 and IE2, IE3 according to IEC 60034-30
- ◆ Degree of protection : IP55
- ◆ Insulation class: the insulation system is designed for temperature class 155°C(F) and checked by temperature class 130°C(B);
- ◆ Cooling method: self-ventilated (IC411) as standard;
- ◆ Support SVC (open-loop vector) control and VF control;
- ◆ Realize speed control;
- ◆ Support Modbus communication and EtherCAT communication;
- ◆ Support local upper computer connection.

2.2.Operating environment

- ◆ Altitude shall not exceed 1000m above seal-level;
- ◆ Allowed temperature between -20°C and 40°C;
- ◆ Permitted relative humidity:
 - 20°C ≤ T ≤ 20°C：100%
 - 20°C ≤ T ≤ 30°C：95%
 - 30°C ≤ T ≤ 40°C：55%

2.3.驱动器规格参数

端口参数	
输出电源	外接24V电源 ● 24VDC±10%, 最大40mA
	外接10V电源 ● +10V-GND, 最大10mA
数字量输入	4通道共COM输入 ● DI0~DI3, 光耦隔离, 支持双向输入
	● 输入电压 12VDC~30VDC
模拟量输入	1通道输入 ● 电压型: DC 0~10V ● 精度1%
LED指示灯	2个双色指示 ● 运行、故障、通信状态指示
通讯端口	RS485通讯 或以太网通讯 ● Modbus RTU 格兰头接口 ● EtherCAT 航空插头
	PC通讯接口 ● RS485通讯, 特制端口 ● 支持PC上位机调试及软件更新

2.3 Drive specification parameters

Port parameters	
Output power supply	External 24V power supply ● 24VDC±10%, max. 40mA
	External 10V power supply ● +10V-GND, max. 10mA
Digital input	4 channels COM input ● DI0~DI3, opto-isolator, support bidirectional input
	● Input voltage: 12VDC~30VDC
Analog input	1 channel input ● Voltage type: DC 0~10V ● Precision: 1%
LED indicator	2 two-color indicator lights ● Indication of running, failure and communication status
Communication port	RS485 communication or EtherCAT communication ● ModBus RTU cable gland port ● EtherCAT aviation plug
	PC communication port ● RS485 communication, Special purpose port
	● Support PC uppercomputer debugging and software update

功率参数 (通用参数)	
输入电压	380...480V 3AC ±10%
输入频率	47...63Hz
输出频率	0...300Hz 50Hz不降容, <50Hz参见降容曲线
载波频率	4kHz (标准)
功率因素	0.95
控制器效率	95...97%
过载能力	1.2倍额定输出电流1min, 1.5倍额定输出电流3sec, 周期10min
电磁兼容	可选符合EN 55011 标准的A级和B级滤波器
防护等级	IP55
工作温度	-20...+40℃不降容, >40...60℃, 参见降容曲线
标准SCCR	10kA
保护功能	● 欠电压
	● 过电压
	● 过载
	● 短路
	● 电机失速保护
	● 电机过载
	● 变频器过温

Power parameter (common parameters)	
Input voltage	380~480V, 3AC, ±10%
Input frequency	47~63Hz
Output frequency	0~300Hz (see the derating curve when frequency less than 50Hz)
Carrier frequency	4kHz (standard)
Power factor	0.95
Efficiency of controller	95~97%
Overload capability	1.2 times rated output current for 1min, 1.5 times rated output current for 3 s within a cycle time of 10min
Electromagnetic compatibility	Class A and B filters are available according to EN 55011
Protection grade	IP55
Operating temperature	-20~+40℃: no derating; 40~60℃: see the derating curve
Standard SCCR	10kA
Defensive function	Under voltage
	Over voltage
	Overload
	Short circuit
	Mortor stall protection
	Motor overload
	Inverter over temperature

2.4.驱动器特性曲线

电流降容 · 环境温度

2.4 Drive characteristic curve

Current derating · environment temperature

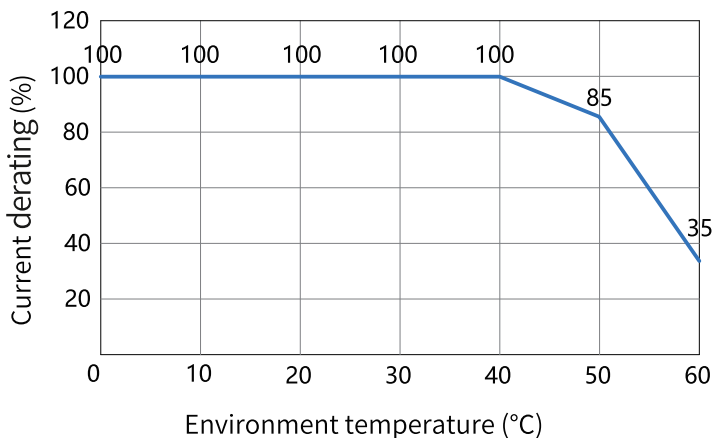

电流降容 · 海拔高度

Current derating · altitude

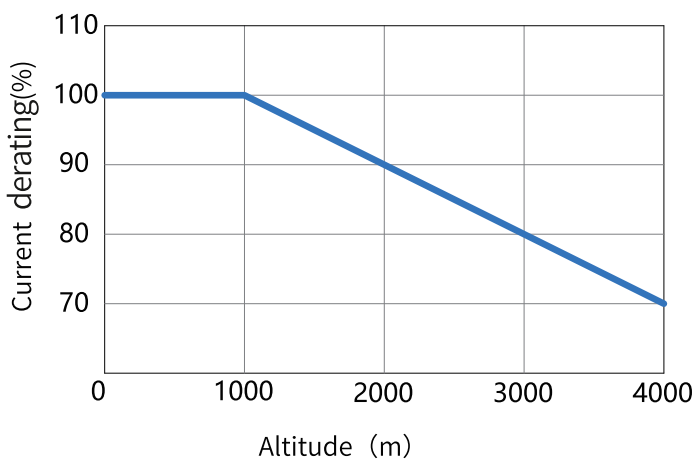

电流降容 · 输出频率

Current derating · output frequency

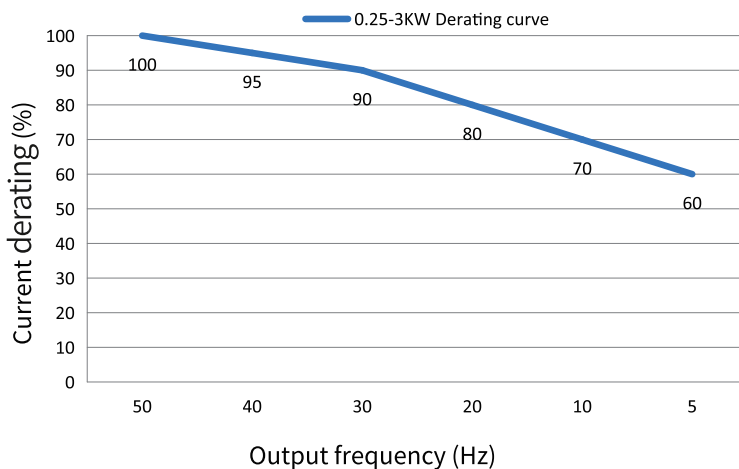

3. 优势特点

(1) 用户友好

安装灵活	具备多方向进线、多方位安装，匹配客户环境需求
参数拷贝	调试一台驱动器，通过PC软件拷贝到其他驱动器
参数分组	功能码合理分组，参数简单直观，方便理解
支持Boneng Drivesoft 软件	参数显示及修改，虚拟示波器，已修改参数等功能方便调试
选配电位器	带电位器旋钮，实现无极调速

(2) 品质可靠

高质量电子元件/电容器	使用寿命更长
所有变频器出厂前进行满负荷测试	可靠性高
完善的驱动器保护功能	平均无故障时间长
带涂层线路板，防潮、防腐蚀外壳	适应更恶劣环境

(3) 性能卓越

过程比例积分(PID)控制器	无需外部控制器
自动识别电机模型	发挥电机的全部潜能
随载随速	轻载高速 重载限速 提升工作效率
跟踪启动(跟踪自由旋转的电机)	避免启动冲击
支持参数互联	参数可互联到P组，可实现启停来源，速度来源等选择来自P组参数，极其灵活
支持自由功能块	支持逻辑，算术运算，延时，数据选择，适用特殊工况参数设置

(4) 成本节约

由于无需机柜和长距离电机电缆，可以节省成本，且系统设计外观漂亮。

3. Advantages

(1) User-friendliness

Flexible installation	With multi-directional cable entry and multi-direction installation, it meet the customer environmental requirements
Parameter copy	Debug a drive and copy it to another drive using PC software
Grouping of parameters	Function code is grouped reasonably and parameters are simple and intuitive for understanding
Support Boneng Drivesoft software	Parameter display and modification, virtual oscilloscope, modified parameters and other functions are convenient for debugging
Optional potentiometer	Stepless speed regulation is achieved with potential knob to achieve

(2) Reliable quality

High quality electronic components/capacitor	Longer service life
All frequency converters are tested at full load before leaving the factory	high reliability
Complete drive protection function	Longer mean time between failures
Coated circuit board, damp and corrosion proof housing	Adapt to the harsher environment

(3) Superior performance

Process proportional integral controller (PID)	No external controller required
Automatic identification of motor models	Develop the full potential of the motor
Following load and speed	Light load with high speed, heavy load with limited speed, thereby improving work efficiency
Trace startup (track freely spinning motors)	Avoid start-up shocks
Support parameter interconnection	The parameters can be interconnected to the P group and realize the parameter selection from the P group such as the start and stop source, the speed source, etc., which is extremely flexible
Support free function modules	Support logic, arithmetic operation, delay, data selection and special working conditions parameter setting

(4) Cost saving

Without cabinets and long-distance motor cables, costs are saved and the system design looks great.

4.型号表示方法

系列名
传动级数
 2级/3级
机座号
安装形式
 H=底脚安装
 F=法兰安装
 S=小法兰安装
 A=轴装式安装
 T=带扭力臂附件安装

输出形式
 A=单向平键实心轴
 C=双向平键实心轴
 G=平键空心轴
 I=锁紧盘空心轴
 K=渐开线花键空心轴

公称减速比代号
安装方位
 D1/D2/D3/D4/D5/D6

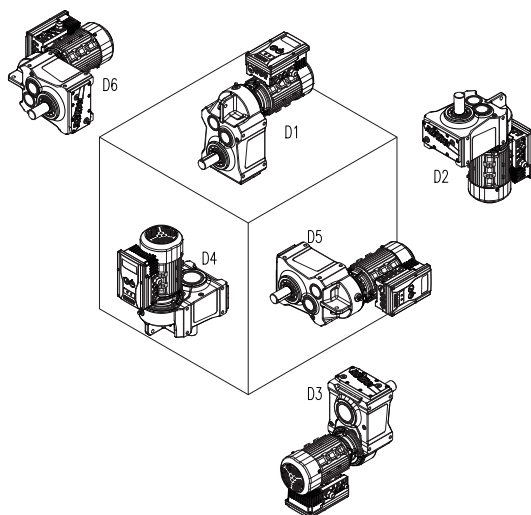

可选附件和指定配置
 0=无可选附件和指定配置
 6=补偿油箱

润滑油代号
 0=不加润滑油 (不加油出厂时, 请选此项)
 1=矿物润滑油VG220 (环境温度 $-20^{\circ}\text{C}\sim+40^{\circ}\text{C}$, 需加油出厂时, 请选此项)
 5=合成润滑油VG220 (环境温度 $<0^{\circ}\text{C}$, 需加油出厂时, 推荐选用此项)

4.Type Designation

Series
Stages
 2-stage/ 3-stage
Size
Mounting Mode
 H=Horizontal foot-mounted
 F=Flange-mounted
 S=Short flange-mounted
 A=Shaft-mounted
 T=Torque arm-mounted with accessory

Output Mode
 A=Unidirectional output shaft
 C=Bidirectional output shaft
 G=Hollow shaft with parallel key
 I=Hollow shaft with shrink disk
 K=Hollow shaft with involute spline

Nominal Ratio Code
Mounting Positions
 D1/D2/D3/D4/D5/D6

Accessories and Specific Configuration
 0=None
 6=Oil Compensating Tank

Oil Code
 0=Without oil filling(Please select this option when you do not need lubricating oil)
 1=With mineral oil VG220(Please select this option when the ambient temperature is $-20^{\circ}\text{C}\sim+40^{\circ}\text{C}$)
 5=With synthetic lubricating oil VG220(It is recommended to select this option when you need lubricating oil and the ambient temperature is below 0°C)

F 3 04 H A - C71 - D1 0 1 -

MH080M4A75 A L 2 - D 0 EC 0 - 0 1 1

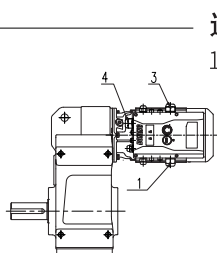

进线孔位置

1/3/4

Cable entry location

1/3/4

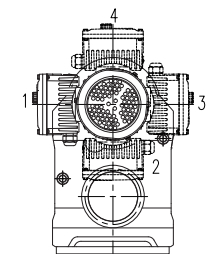

接线盒位置

1/2/3/4

Terminal box location

1/2/3/4

马达安装方位 0

Motor mounting position 0

一体机防护等级

0=IP55

1=IP55和防雨罩

Protection degree

0=IP55

1=IP55+Rain cover

通讯协议

MB=Modbus RTU

EC=EtherCAT

Communication protocol

MB=Modbus RTU

EC=EtherCAT

调速旋钮 1)

0=无调速旋钮

1=有调速旋钮

Speed control knob 1)

0=No speed control knob

1=Speed control knob

驱动器

D=分布式

Drive

D=Distributed

频率/电压代号

2=47~63Hz/380~480V

Code of voltage and frequency

2=47~63Hz/380~480V

机座材质

L=铝机座

Cast-aluminum frame

L=Aluminum

安装形式A

Construction type A

功率 (kW)	MH=IE2三相交流异步马达4极规格 MP=IE3三相交流异步马达4极规格		
Power(kw)	MH=IE2 4-pole three-phase asynchronous motor MP=IE3 4-pole three-phase asynchronous motor		
0.25	MH071M4A25... MP071M4A25...	1.1	MH090S4B11... MP090S4B11...
0.37	MH071M4A37... MP071M4A37...	1.5	MH090S4B15... MP090M4B15...
0.55	MH080M4A55... MP080M4A55...	2.2	MH100M4B22... MP100M4B22...
0.75	MH080M4A75... MP080M4A75...	3	MH100M4B30... MP100M4B30...

5.传动能力表

5.Transmission Capacity

马达 额定功率	马达 额定转速	减速机实际 输出转速	减速机实际 输出扭矩	减速机公称 减速比代号	减速机公称 减速比	减速机精确 减速比	减速机额定 输出扭矩	服务系数	通讯方式	订货号
Motor Rated Power	Motor Rated Speed	Actual Output Speed of Gearmotor	Actual Output Torque of Gearmotor	Nominal Ratio Code of Gearmotor	Nominal Ratio of Gearmotor	Exact Ratio of Gearmotor	Normal Output Torque of Gearmotor	Service Coefficient	Communication Mode	Order Code
P _{IN} (kw)	n _{IN} (r/min)	n _{2N} (r/min)	T ₂ (N.m)	Code	i _N	i _{ex}	T _{2N} (N.m)	f		
0.25	1380	349	6.7	B40	4	3.95	130	19.4	MB/EC	F202□□-B40-D□□□-□□071□4A25AL□-D□□□□-0□□
0.25	1380	309	7.6	B45	4.5	4.46	140	18.42	MB/EC	F202□□-B45-D□□□-□□071□4A25AL□-D□□□□-0□□
0.25	1380	272	8.6	B50	5	5.08	140	16.28	MB/EC	F202□□-B50-D□□□-□□071□4A25AL□-D□□□□-0□□
0.25	1380	240	9.8	B56	5.6	5.74	150	15.31	MB/EC	F202□□-B56-D□□□-□□071□4A25AL□-D□□□□-0□□
0.25	1380	212	11	B63	6.3	6.50	150	13.64	MB/EC	F202□□-B63-D□□□-□□071□4A25AL□-D□□□□-0□□
0.25	1380	197	12	B71	7.1	7.00	150	12.5	MB/EC	F202□□-B71-D□□□-□□071□4A25AL□-D□□□□-0□□
0.25	1380	177	13	B80	8	7.80	150	11.54	MB/EC	F202□□-B80-D□□□-□□071□4A25AL□-D□□□□-0□□
0.25	1380	157	15	B90	9	8.79	150	10	MB/EC	F202□□-B90-D□□□-□□071□4A25AL□-D□□□□-0□□
0.25	1380	138	17	C10	10	10.0	150	8.82	MB/EC	F202□□-C10-D□□□-□□071□4A25AL□-D□□□□-0□□
0.25	1380	122	19	C11	11.2	11.3	150	7.89	MB/EC	F202□□-C11-D□□□-□□071□4A25AL□-D□□□□-0□□
0.25	1380	108	22	C13	12.5	12.8	150	6.82	MB/EC	F202□□-C13-D□□□-□□071□4A25AL□-D□□□□-0□□
0.25	1380	100	23	C14	14	13.8	150	6.52	MB/EC	F202□□-C14-D□□□-□□071□4A25AL□-D□□□□-0□□
0.25	1380	86.3	27	C16	16	16.0	150	5.56	MB/EC	F302□□-C16-D□□□-□□071□4A25AL□-D□□□□-0□□
0.25	1380	78	30	C18	18	17.7	150	5	MB/EC	F302□□-C18-D□□□-□□071□4A25AL□-D□□□□-0□□
0.25	1380	69.3	34	C20	20	19.9	150	4.41	MB/EC	F302□□-C20-D□□□-□□071□4A25AL□-D□□□□-0□□
0.25	1380	60.8	39	C22	22.4	22.7	150	3.85	MB/EC	F302□□-C22-D□□□-□□071□4A25AL□-D□□□□-0□□
0.25	1380	53.7	44	C25	25	25.7	150	3.41	MB/EC	F302□□-C25-D□□□-□□071□4A25AL□-D□□□□-0□□
0.25	1380	47.4	49	C28	28	29.1	150	3.06	MB/EC	F302□□-C28-D□□□-□□071□4A25AL□-D□□□□-0□□
0.25	1380	44.1	53	C32	31.5	31.3	150	2.83	MB/EC	F302□□-C32-D□□□-□□071□4A25AL□-D□□□□-0□□
0.25	1380	39.5	59	C36	35.5	34.9	150	2.54	MB/EC	F302□□-C36-D□□□-□□071□4A25AL□-D□□□□-0□□
0.25	1380	35.1	67	C40	40	39.3	150	2.24	MB/EC	F302□□-C40-D□□□-□□071□4A25AL□-D□□□□-0□□
0.25	1380	30.8	76	C45	45	44.8	150	1.97	MB/EC	F302□□-C45-D□□□-□□071□4A25AL□-D□□□□-0□□
0.25	1380	27.3	86	C50	50	50.6	150	1.74	MB/EC	F302□□-C50-D□□□-□□071□4A25AL□-D□□□□-0□□
0.25	1380	24.1	97	C56	56	57.3	150	1.55	MB/EC	F302□□-C56-D□□□-□□071□4A25AL□-D□□□□-0□□
0.25	1380	22.4	105	C63	63	61.7	150	1.43	MB/EC	F302□□-C63-D□□□-□□071□4A25AL□-D□□□□-0□□
0.25	1380	19.1	123	C71	71	72.3	150	1.22	MB/EC	F302□□-C71-D□□□-□□071□4A25AL□-D□□□□-0□□
0.25	1380	16.8	139	C80	80	81.9	150	1.08	MB/EC	F302□□-C80-D□□□-□□071□4A25AL□-D□□□□-0□□
0.25	1380	15.3	154	C90	90	90.3	150	0.97	MB/EC	F302□□-C90-D□□□-□□071□4A25AL□-D□□□□-0□□
0.25	1380	14	168	D10	100	98.7	150	0.89	MB/EC	F302□□-D10-D□□□-□□071□4A25AL□-D□□□□-0□□
0.25	1380	12.8	183	D11	112	107.9	150	0.82	MB/EC	F302□□-D11-D□□□-□□071□4A25AL□-D□□□□-0□□
0.25	1380	17.3	135	C80	80	79.6	240	1.78	MB/EC	F303□□-C80-D□□□-□□071□4A25AL□-D□□□□-0□□
0.25	1380	15.3	153	C90	90	90.2	240	1.57	MB/EC	F303□□-C90-D□□□-□□071□4A25AL□-D□□□□-0□□
0.25	1380	13.9	169	D10	100	99.4	240	1.42	MB/EC	F303□□-D10-D□□□-□□071□4A25AL□-D□□□□-0□□
0.25	1380	12.7	185	D11	112	108.7	240	1.3	MB/EC	F303□□-D11-D□□□-□□071□4A25AL□-D□□□□-0□□
0.25	1380	11.6	202	D13	125	118.8	240	1.19	MB/EC	F303□□-D13-D□□□-□□071□4A25AL□-D□□□□-0□□

马达 额定功率	马达 额定转速	减速机实际 输出转速	减速机实际 输出扭矩	减速机公称 减速比代号	减速机公称 减速比	减速机精确 减速比	减速机额定 输出扭矩	服务系数	通讯方式	订货号
Motor Rated Power	Motor Rated Speed	Actual Output Speed of Gearmotor	Actual Output Torque of Gearmotor	Nominal Ratio Code of Gearmotor	Nominal Ratio of Gearmotor	Exact Ratio of Gearmotor	Normal Output Torque of Gearmotor	Service Coefficient	Communication Mode	Order Code
P _{1N} (kw)	n _{1N} (r/min)	n _{2N} (r/min)	T ₂ (N.m)	Code	i _N	i _{ex}	T _{2N} (N.m)	f		
0.37	1385	351	10	B40	4	3.95	130	13	MB/EC	F202□□-B40-D□□□-□□071□4A37AL□-D□□□□-0□□
0.37	1385	311	12	B45	4.5	4.46	140	11.67	MB/EC	F202□□-B45-D□□□-□□071□4A37AL□-D□□□□-0□□
0.37	1385	273	13	B50	5	5.08	140	10.77	MB/EC	F202□□-B50-D□□□-□□071□4A37AL□-D□□□□-0□□
0.37	1385	241	15	B56	5.6	5.74	150	10	MB/EC	F202□□-B56-D□□□-□□071□4A37AL□-D□□□□-0□□
0.37	1385	213	17	B63	6.3	6.50	150	8.82	MB/EC	F202□□-B63-D□□□-□□071□4A37AL□-D□□□□-0□□
0.37	1385	198	18	B71	7.1	7.00	150	8.33	MB/EC	F202□□-B71-D□□□-□□071□4A37AL□-D□□□□-0□□
0.37	1385	178	20	B80	8	7.80	150	7.5	MB/EC	F202□□-B80-D□□□-□□071□4A37AL□-D□□□□-0□□
0.37	1385	158	23	B90	9	8.79	150	6.52	MB/EC	F202□□-B90-D□□□-□□071□4A37AL□-D□□□□-0□□
0.37	1385	139	26	C10	10	10.0	150	5.77	MB/EC	F202□□-C10-D□□□-□□071□4A37AL□-D□□□□-0□□
0.37	1385	123	29	C11	11.2	11.3	150	5.17	MB/EC	F202□□-C11-D□□□-□□071□4A37AL□-D□□□□-0□□
0.37	1385	108	33	C13	12.5	12.8	150	4.55	MB/EC	F202□□-C13-D□□□-□□071□4A37AL□-D□□□□-0□□
0.37	1385	100	36	C14	14	13.8	150	4.17	MB/EC	F202□□-C14-D□□□-□□071□4A37AL□-D□□□□-0□□
0.37	1385	86.6	42	C16	16	16.0	150	3.57	MB/EC	F302□□-C16-D□□□-□□071□4A37AL□-D□□□□-0□□
0.37	1385	78.2	46	C18	18	17.7	150	3.26	MB/EC	F302□□-C18-D□□□-□□071□4A37AL□-D□□□□-0□□
0.37	1385	69.6	52	C20	20	19.9	150	2.88	MB/EC	F302□□-C20-D□□□-□□071□4A37AL□-D□□□□-0□□
0.37	1385	61	59	C22	22.4	22.7	150	2.54	MB/EC	F302□□-C22-D□□□-□□071□4A37AL□-D□□□□-0□□
0.37	1385	53.9	67	C25	25	25.7	150	2.24	MB/EC	F302□□-C25-D□□□-□□071□4A37AL□-D□□□□-0□□
0.37	1385	47.6	76	C28	28	29.1	150	1.97	MB/EC	F302□□-C28-D□□□-□□071□4A37AL□-D□□□□-0□□
0.37	1385	44.2	81	C32	31.5	31.3	150	1.85	MB/EC	F302□□-C32-D□□□-□□071□4A37AL□-D□□□□-0□□
0.37	1385	39.7	91	C36	35.5	34.9	150	1.65	MB/EC	F302□□-C36-D□□□-□□071□4A37AL□-D□□□□-0□□
0.37	1385	35.2	102	C40	40	39.3	150	1.47	MB/EC	F302□□-C40-D□□□-□□071□4A37AL□-D□□□□-0□□
0.37	1385	30.9	116	C45	45	44.8	150	1.29	MB/EC	F302□□-C45-D□□□-□□071□4A37AL□-D□□□□-0□□
0.37	1385	27.4	132	C50	50	50.6	150	1.14	MB/EC	F302□□-C50-D□□□-□□071□4A37AL□-D□□□□-0□□
0.37	1385	24.2	149	C56	56	57.3	150	1.01	MB/EC	F302□□-C56-D□□□-□□071□4A37AL□-D□□□□-0□□
0.37	1385	22.4	160	C63	63	61.7	150	0.94	MB/EC	F302□□-C63-D□□□-□□071□4A37AL□-D□□□□-0□□
0.37	1385	19.2	188	C71	71	72.3	150	0.8	MB/EC	F302□□-C71-D□□□-□□071□4A37AL□-D□□□□-0□□
0.37	1385	24.8	145	C56	56	55.8	240	1.66	MB/EC	F303□□-C56-D□□□-□□071□4A37AL□-D□□□□-0□□
0.37	1385	21.9	164	C63	63	63.1	240	1.46	MB/EC	F303□□-C63-D□□□-□□071□4A37AL□-D□□□□-0□□
0.37	1385	20.4	177	C71	71	68.0	240	1.36	MB/EC	F303□□-C71-D□□□-□□071□4A37AL□-D□□□□-0□□
0.37	1385	17.4	207	C80	80	79.6	240	1.16	MB/EC	F303□□-C80-D□□□-□□071□4A37AL□-D□□□□-0□□
0.37	1385	15.4	235	C90	90	90.2	240	1.02	MB/EC	F303□□-C90-D□□□-□□071□4A37AL□-D□□□□-0□□
0.37	1385	13.9	258	D10	100	99.4	240	0.93	MB/EC	F303□□-D10-D□□□-□□071□4A37AL□-D□□□□-0□□
0.37	1385	12.7	283	D11	112	108.7	240	0.85	MB/EC	F303□□-D11-D□□□-□□071□4A37AL□-D□□□□-0□□
0.37	1385	15.1	239	D10	100	91.9	430	1.8	MB/EC	F304□□-D10-D□□□-□□071□4A37AL□-D□□□□-0□□
0.37	1385	13	278	D11	112	106.8	440	1.58	MB/EC	F304□□-D11-D□□□-□□071□4A37AL□-D□□□□-0□□
0.37	1385	11.5	313	D13	125	120.2	440	1.41	MB/EC	F304□□-D13-D□□□-□□071□4A37AL□-D□□□□-0□□
0.37	1385	9.6	374	D14	140	144.0	440	1.18	MB/EC	F304□□-D14-D□□□-□□071□4A37AL□-D□□□□-0□□
0.37	1385	8.9	407	D16	160	156.4	440	1.08	MB/EC	F304□□-D16-D□□□-□□071□4A37AL□-D□□□□-0□□

马达 额定功率	马达 额定转速	减速机实际 输出转速	减速机实际 输出扭矩	减速机公称 减速比代号	减速机公称 减速比	减速机精确 减速比	减速机额定 输出扭矩	服务系数	通讯方式	订货号
Motor Rated Power	Motor Rated Speed	Actual Output Speed of Gearmotor	Actual Output Torque of Gearmotor	Nominal Ratio Code of Gearmotor	Nominal Ratio of Gearmotor	Exact Ratio of Gearmotor	Normal Output Torque of Gearmotor	Service Coefficient	Communication Mode	Order Code
P _{IN} (kw)	n _{1N} (r/min)	n _{2N} (r/min)	T ₂ (N.m)	Code	i _N	i _{ex}	T _{2N} (N.m)	f		
0.55	1430	362	15	B40	4	3.95	130	8.67	MB/EC	F202□□-B40-D□□□-□□080□4A55AL□-D□□□□-0□□
0.55	1430	321	17	B45	4.5	4.46	140	8.24	MB/EC	F202□□-B45-D□□□-□□080□4A55AL□-D□□□□-0□□
0.55	1430	281	19	B50	5	5.08	140	7.37	MB/EC	F202□□-B50-D□□□-□□080□4A55AL□-D□□□□-0□□
0.55	1430	249	21	B56	5.6	5.74	150	7.14	MB/EC	F202□□-B56-D□□□-□□080□4A55AL□-D□□□□-0□□
0.55	1430	220	24	B63	6.3	6.50	150	6.25	MB/EC	F202□□-B63-D□□□-□□080□4A55AL□-D□□□□-0□□
0.55	1430	204	26	B71	7.1	7.00	150	5.77	MB/EC	F202□□-B71-D□□□-□□080□4A55AL□-D□□□□-0□□
0.55	1430	183	29	B80	8	7.80	150	5.17	MB/EC	F202□□-B80-D□□□-□□080□4A55AL□-D□□□□-0□□
0.55	1430	163	33	B90	9	8.79	150	4.55	MB/EC	F202□□-B90-D□□□-□□080□4A55AL□-D□□□□-0□□
0.55	1430	143	37	C10	10	10.0	150	4.05	MB/EC	F202□□-C10-D□□□-□□080□4A55AL□-D□□□□-0□□
0.55	1430	127	42	C11	11.2	11.3	150	3.57	MB/EC	F202□□-C11-D□□□-□□080□4A55AL□-D□□□□-0□□
0.55	1430	112	47	C13	12.5	12.8	150	3.19	MB/EC	F202□□-C13-D□□□-□□080□4A55AL□-D□□□□-0□□
0.55	1430	104	51	C14	14	13.8	150	2.94	MB/EC	F202□□-C14-D□□□-□□080□4A55AL□-D□□□□-0□□
0.55	1430	89.4	59	C16	16	16.0	150	2.54	MB/EC	F302□□-C16-D□□□-□□080□4A55AL□-D□□□□-0□□
0.55	1430	80.8	65	C18	18	17.7	150	2.31	MB/EC	F302□□-C18-D□□□-□□080□4A55AL□-D□□□□-0□□
0.55	1430	71.9	74	C20	20	19.9	150	2.03	MB/EC	F302□□-C20-D□□□-□□080□4A55AL□-D□□□□-0□□
0.55	1430	63	84	C22	22.4	22.7	150	1.79	MB/EC	F302□□-C22-D□□□-□□080□4A55AL□-D□□□□-0□□
0.55	1430	55.6	95	C25	25	25.7	150	1.58	MB/EC	F302□□-C25-D□□□-□□080□4A55AL□-D□□□□-0□□
0.55	1430	49.1	108	C28	28	29.1	150	1.39	MB/EC	F302□□-C28-D□□□-□□080□4A55AL□-D□□□□-0□□
0.55	1430	45.7	116	C32	31.5	31.3	150	1.29	MB/EC	F302□□-C32-D□□□-□□080□4A55AL□-D□□□□-0□□
0.55	1430	41	129	C36	35.5	34.9	150	1.16	MB/EC	F302□□-C36-D□□□-□□080□4A55AL□-D□□□□-0□□
0.55	1430	36.4	145	C40	40	39.3	150	1.03	MB/EC	F302□□-C40-D□□□-□□080□4A55AL□-D□□□□-0□□
0.55	1430	31.9	166	C45	45	44.8	150	0.9	MB/EC	F302□□-C45-D□□□-□□080□4A55AL□-D□□□□-0□□
0.55	1430	28.3	187	C50	50	50.6	150	0.8	MB/EC	F302□□-C50-D□□□-□□080□4A55AL□-D□□□□-0□□
0.55	1430	37.2	142	C40	40	38.4	240	1.69	MB/EC	F303□□-C40-D□□□-□□080□4A55AL□-D□□□□-0□□
0.55	1430	33	160	C45	45	43.3	240	1.5	MB/EC	F303□□-C45-D□□□-□□080□4A55AL□-D□□□□-0□□
0.55	1430	29	182	C50	50	49.3	240	1.32	MB/EC	F303□□-C50-D□□□-□□080□4A55AL□-D□□□□-0□□
0.55	1430	25.6	206	C56	56	55.8	240	1.17	MB/EC	F303□□-C56-D□□□-□□080□4A55AL□-D□□□□-0□□
0.55	1430	22.7	233	C63	63	63.1	240	1.03	MB/EC	F303□□-C63-D□□□-□□080□4A55AL□-D□□□□-0□□
0.55	1430	21	252	C71	71	68.0	240	0.95	MB/EC	F303□□-C71-D□□□-□□080□4A55AL□-D□□□□-0□□
0.55	1430	18	295	C80	80	79.6	240	0.81	MB/EC	F303□□-C80-D□□□-□□080□4A55AL□-D□□□□-0□□
0.55	1430	23.6	224	C63	63	60.6	430	1.92	MB/EC	F304□□-C63-D□□□-□□080□4A55AL□-D□□□□-0□□
0.55	1430	20.6	257	C71	71	69.4	430	1.67	MB/EC	F304□□-C71-D□□□-□□080□4A55AL□-D□□□□-0□□
0.55	1430	18.7	282	C80	80	76.3	430	1.52	MB/EC	F304□□-C80-D□□□-□□080□4A55AL□-D□□□□-0□□
0.55	1430	16.6	318	C90	90	86.0	430	1.35	MB/EC	F304□□-C90-D□□□-□□080□4A55AL□-D□□□□-0□□
0.55	1430	15.6	340	D10	100	91.9	430	1.26	MB/EC	F304□□-D10-D□□□-□□080□4A55AL□-D□□□□-0□□
0.55	1430	13.4	395	D11	112	106.8	440	1.11	MB/EC	F304□□-D11-D□□□-□□080□4A55AL□-D□□□□-0□□
0.55	1430	11.9	445	D13	125	120.2	440	0.99	MB/EC	F304□□-D13-D□□□-□□080□4A55AL□-D□□□□-0□□
0.55	1430	9.9	533	D14	140	144.0	440	0.83	MB/EC	F304□□-D14-D□□□-□□080□4A55AL□-D□□□□-0□□
0.55	1430	13.4	395	D11	112	106.7	700	1.77	MB/EC	F305□□-D11-D□□□-□□080□4A55AL□-D□□□□-0□□
0.55	1430	12.2	433	D13	125	117.0	700	1.62	MB/EC	F305□□-D13-D□□□-□□080□4A55AL□-D□□□□-0□□
0.55	1430	11.3	470	D14	140	127.1	700	1.49	MB/EC	F305□□-D14-D□□□-□□080□4A55AL□-D□□□□-0□□

马达 额定功率	马达 额定转速	减速机实际 输出转速	减速机实际 输出扭矩	减速机公称 减速比代号	减速机公称 减速比	减速机精确 减速比	减速机额定 输出扭矩	服务系数	通讯方式	订货号
Motor Rated Power	Motor Rated Speed	Actual Output Speed of Gearmotor	Actual Output Torque of Gearmotor	Nominal Ratio Code of Gearmotor	Nominal Ratio of Gearmotor	Exact Ratio of Gearmotor	Normal Output Torque of Gearmotor	Service Coefficient	Communication Mode	Order Code
P _{IN} (kw)	n _{1N} (r/min)	n _{2N} (r/min)	T ₂ (N.m)	Code	i _N	i _{ex}	T _{2N} (N.m)	f		
0.75	1430	362	20	B40	4	3.95	130	6.5	MB/EC	F202□□-B40-D□□□-□□080□4A75AL□-D□□□□-0□□□
0.75	1430	321	22	B45	4.5	4.46	140	6.36	MB/EC	F202□□-B45-D□□□-□□080□4A75AL□-D□□□□-0□□□
0.75	1430	281	25	B50	5	5.08	140	5.6	MB/EC	F202□□-B50-D□□□-□□080□4A75AL□-D□□□□-0□□□
0.75	1430	249	29	B56	5.6	5.74	150	5.17	MB/EC	F202□□-B56-D□□□-□□080□4A75AL□-D□□□□-0□□□
0.75	1430	220	33	B63	6.3	6.50	150	4.55	MB/EC	F202□□-B63-D□□□-□□080□4A75AL□-D□□□□-0□□□
0.75	1430	204	35	B71	7.1	7.00	150	4.29	MB/EC	F202□□-B71-D□□□-□□080□4A75AL□-D□□□□-0□□□
0.75	1430	183	39	B80	8	7.80	150	3.85	MB/EC	F202□□-B80-D□□□-□□080□4A75AL□-D□□□□-0□□□
0.75	1430	163	44	B90	9	8.79	150	3.41	MB/EC	F202□□-B90-D□□□-□□080□4A75AL□-D□□□□-0□□□
0.75	1430	143	50	C10	10	10.0	150	3	MB/EC	F202□□-C10-D□□□-□□080□4A75AL□-D□□□□-0□□□
0.75	1430	127	57	C11	11.2	11.3	150	2.63	MB/EC	F202□□-C11-D□□□-□□080□4A75AL□-D□□□□-0□□□
0.75	1430	112	64	C13	12.5	12.8	150	2.34	MB/EC	F202□□-C13-D□□□-□□080□4A75AL□-D□□□□-0□□□
0.75	1430	104	69	C14	14	13.8	150	2.17	MB/EC	F202□□-C14-D□□□-□□080□4A75AL□-D□□□□-0□□□
0.75	1430	89.4	80	C16	16	16.0	150	1.88	MB/EC	F302□□-C16-D□□□-□□080□4A75AL□-D□□□□-0□□□
0.75	1430	80.8	89	C18	18	17.7	150	1.69	MB/EC	F302□□-C18-D□□□-□□080□4A75AL□-D□□□□-0□□□
0.75	1430	71.9	100	C20	20	19.9	150	1.5	MB/EC	F302□□-C20-D□□□-□□080□4A75AL□-D□□□□-0□□□
0.75	1430	63	114	C22	22.4	22.7	150	1.32	MB/EC	F302□□-C22-D□□□-□□080□4A75AL□-D□□□□-0□□□
0.75	1430	55.6	129	C25	25	25.7	150	1.16	MB/EC	F302□□-C25-D□□□-□□080□4A75AL□-D□□□□-0□□□
0.75	1430	49.1	146	C28	28	29.1	150	1.03	MB/EC	F302□□-C28-D□□□-□□080□4A75AL□-D□□□□-0□□□
0.75	1430	45.7	157	C32	31.5	31.3	150	0.96	MB/EC	F302□□-C32-D□□□-□□080□4A75AL□-D□□□□-0□□□
0.75	1430	41	175	C36	35.5	34.9	150	0.86	MB/EC	F302□□-C36-D□□□-□□080□4A75AL□-D□□□□-0□□□
0.75	1430	49.5	145	C28	28	28.9	240	1.66	MB/EC	F303□□-C28-D□□□-□□080□4A75AL□-D□□□□-0□□□
0.75	1430	46	156	C32	31.5	31.1	240	1.54	MB/EC	F303□□-C32-D□□□-□□080□4A75AL□-D□□□□-0□□□
0.75	1430	41.1	174	C36	35.5	34.8	240	1.38	MB/EC	F303□□-C36-D□□□-□□080□4A75AL□-D□□□□-0□□□
0.75	1430	37.2	192	C40	40	38.4	240	1.25	MB/EC	F303□□-C40-D□□□-□□080□4A75AL□-D□□□□-0□□□
0.75	1430	33	217	C45	45	43.3	240	1.11	MB/EC	F303□□-C45-D□□□-□□080□4A75AL□-D□□□□-0□□□
0.75	1430	29	247	C50	50	49.3	240	0.97	MB/EC	F303□□-C50-D□□□-□□080□4A75AL□-D□□□□-0□□□
0.75	1430	25.6	279	C56	56	55.8	240	0.86	MB/EC	F303□□-C56-D□□□-□□080□4A75AL□-D□□□□-0□□□
0.75	1430	29.6	242	C50	50	48.3	420	1.74	MB/EC	F304□□-C50-D□□□-□□080□4A75AL□-D□□□□-0□□□
0.75	1430	26.2	273	C56	56	54.6	420	1.54	MB/EC	F304□□-C56-D□□□-□□080□4A75AL□-D□□□□-0□□□
0.75	1430	23.6	303	C63	63	60.6	430	1.42	MB/EC	F304□□-C63-D□□□-□□080□4A75AL□-D□□□□-0□□□
0.75	1430	20.6	347	C71	71	69.4	430	1.24	MB/EC	F304□□-C71-D□□□-□□080□4A75AL□-D□□□□-0□□□
0.75	1430	18.7	382	C80	80	76.3	430	1.13	MB/EC	F304□□-C80-D□□□-□□080□4A75AL□-D□□□□-0□□□
0.75	1430	16.6	430	C90	90	86.0	430	1	MB/EC	F304□□-C90-D□□□-□□080□4A75AL□-D□□□□-0□□□
0.75	1430	15.6	460	D10	100	91.9	430	0.93	MB/EC	F304□□-D10-D□□□-□□080□4A75AL□-D□□□□-0□□□
0.75	1430	13.4	534	D11	112	106.8	440	0.82	MB/EC	F304□□-D11-D□□□-□□080□4A75AL□-D□□□□-0□□□
0.75	1430	16.5	434	C90	90	86.8	700	1.61	MB/EC	F305□□-C90-D□□□-□□080□4A75AL□-D□□□□-0□□□
0.75	1430	14.6	489	D10	100	97.7	700	1.43	MB/EC	F305□□-D10-D□□□-□□080□4A75AL□-D□□□□-0□□□
0.75	1430	13.4	534	D11	112	106.7	700	1.31	MB/EC	F305□□-D11-D□□□-□□080□4A75AL□-D□□□□-0□□□
0.75	1430	12.2	585	D13	125	117.0	700	1.2	MB/EC	F305□□-D13-D□□□-□□080□4A75AL□-D□□□□-0□□□
0.75	1430	11.3	636	D14	140	127.1	700	1.1	MB/EC	F305□□-D14-D□□□-□□080□4A75AL□-D□□□□-0□□□
0.75	1430	12.6	568	D11	112	113.6	900	1.58	MB/EC	F306□□-D11-D□□□-□□080□4A75AL□-D□□□□-0□□□
0.75	1430	10.9	657	D13	125	131.4	900	1.37	MB/EC	F306□□-D13-D□□□-□□080□4A75AL□-D□□□□-0□□□
0.75	1430	10.3	695	D14	140	138.9	900	1.29	MB/EC	F306□□-D14-D□□□-□□080□4A75AL□-D□□□□-0□□□
0.75	1430	9.2	781	D16	160	156.2	900	1.15	MB/EC	F306□□-D16-D□□□-□□080□4A75AL□-D□□□□-0□□□
0.75	1430	8.6	831	D18	180	166.2	900	1.08	MB/EC	F306□□-D18-D□□□-□□080□4A75AL□-D□□□□-0□□□
0.75	1430	7.6	939	D20	200	187.7	900	0.96	MB/EC	F306□□-D20-D□□□-□□080□4A75AL□-D□□□□-0□□□

马达 额定功率	马达 额定转速	减速机实际 输出转速	减速机实际 输出扭矩	减速机公称 减速比代号	减速机公称 减速比	减速机精确 减速比	减速机额定 输出扭矩	服务系数	通讯方式	订货号
Motor Rated Power	Motor Rated Speed	Actual Output Speed of Gearmotor	Actual Output Torque of Gearmotor	Nominal Ratio Code of Gearmotor	Nominal Ratio of Gearmotor	Exact Ratio of Gearmotor	Normal Output Torque of Gearmotor	Service Coefficient	Communication Mode	Order Code
P _{1N} (kw)	n _{1N} (r/min)	n _{2N} (r/min)	T ₂ (N.m)	Code	i _N	i _{ex}	T _{2N} (N.m)	f		
1.1	1435	363	29	B40	4	3.95	130	4.48	MB/EC	F202□□-B40-D□□□-□□090□4B11AL□-D□□□□-0□□
1.1	1435	322	33	B45	4.5	4.46	140	4.24	MB/EC	F202□□-B45-D□□□-□□090□4B11AL□-D□□□□-0□□
1.1	1435	282	37	B50	5	5.08	140	3.78	MB/EC	F202□□-B50-D□□□-□□090□4B11AL□-D□□□□-0□□
1.1	1435	250	42	B56	5.6	5.74	150	3.57	MB/EC	F202□□-B56-D□□□-□□090□4B11AL□-D□□□□-0□□
1.1	1435	221	47	B63	6.3	6.50	150	3.19	MB/EC	F202□□-B63-D□□□-□□090□4B11AL□-D□□□□-0□□
1.1	1435	205	51	B71	7.1	7.00	150	2.94	MB/EC	F202□□-B71-D□□□-□□090□4B11AL□-D□□□□-0□□
1.1	1435	184	57	B80	8	7.80	150	2.63	MB/EC	F202□□-B80-D□□□-□□090□4B11AL□-D□□□□-0□□
1.1	1435	163	64	B90	9	8.79	150	2.34	MB/EC	F202□□-B90-D□□□-□□090□4B11AL□-D□□□□-0□□
1.1	1435	144	73	C10	10	10.0	150	2.05	MB/EC	F202□□-C10-D□□□-□□090□4B11AL□-D□□□□-0□□
1.1	1435	127	82	C11	11.2	11.3	150	1.83	MB/EC	F202□□-C11-D□□□-□□090□4B11AL□-D□□□□-0□□
1.1	1435	112	93	C13	12.5	12.8	150	1.61	MB/EC	F202□□-C13-D□□□-□□090□4B11AL□-D□□□□-0□□
1.1	1435	104	101	C14	14	13.8	150	1.49	MB/EC	F202□□-C14-D□□□-□□090□4B11AL□-D□□□□-0□□
1.1	1435	89.7	117	C16	16	16.0	150	1.28	MB/EC	F302□□-C16-D□□□-□□090□4B11AL□-D□□□□-0□□
1.1	1435	81.1	129	C18	18	17.7	150	1.16	MB/EC	F302□□-C18-D□□□-□□090□4B11AL□-D□□□□-0□□
1.1	1435	72.1	145	C20	20	19.9	150	1.03	MB/EC	F302□□-C20-D□□□-□□090□4B11AL□-D□□□□-0□□
1.1	1435	63.2	166	C22	22.4	22.7	150	0.9	MB/EC	F302□□-C22-D□□□-□□090□4B11AL□-D□□□□-0□□
1.1	1435	55.8	188	C25	25	25.7	150	0.8	MB/EC	F302□□-C25-D□□□-□□090□4B11AL□-D□□□□-0□□
1.1	1435	74.4	141	C20	20	19.3	240	1.7	MB/EC	F203□□-C20-D□□□-□□090□4B11AL□-D□□□□-0□□
1.1	1435	63.8	164	C22	22.4	22.5	240	1.46	MB/EC	F303□□-C22-D□□□-□□090□4B11AL□-D□□□□-0□□
1.1	1435	56.3	186	C25	25	25.5	240	1.29	MB/EC	F303□□-C25-D□□□-□□090□4B11AL□-D□□□□-0□□
1.1	1435	49.7	211	C28	28	28.9	240	1.14	MB/EC	F303□□-C28-D□□□-□□090□4B11AL□-D□□□□-0□□
1.1	1435	46.1	227	C32	31.5	31.1	240	1.06	MB/EC	F303□□-C32-D□□□-□□090□4B11AL□-D□□□□-0□□
1.1	1435	41.2	254	C36	35.5	34.8	240	0.94	MB/EC	F303□□-C36-D□□□-□□090□4B11AL□-D□□□□-0□□
1.1	1435	37.4	280	C40	40	38.4	240	0.86	MB/EC	F303□□-C40-D□□□-□□090□4B11AL□-D□□□□-0□□
1.1	1435	46.6	225	C32	31.5	30.8	480	2.13	MB/EC	F304□□-C32-D□□□-□□090□4B11AL□-D□□□□-0□□
1.1	1435	42	250	C36	35.5	34.2	480	1.92	MB/EC	F304□□-C36-D□□□-□□090□4B11AL□-D□□□□-0□□
1.1	1435	36.6	286	C40	40	39.2	480	1.68	MB/EC	F304□□-C40-D□□□-□□090□4B11AL□-D□□□□-0□□
1.1	1435	33.4	314	C45	45	43.0	420	1.34	MB/EC	F304□□-C45-D□□□-□□090□4B11AL□-D□□□□-0□□
1.1	1435	29.7	353	C50	50	48.3	420	1.19	MB/EC	F304□□-C50-D□□□-□□090□4B11AL□-D□□□□-0□□
1.1	1435	26.3	399	C56	56	54.6	420	1.05	MB/EC	F304□□-C56-D□□□-□□090□4B11AL□-D□□□□-0□□
1.1	1435	23.7	442	C63	63	60.6	430	0.97	MB/EC	F304□□-C63-D□□□-□□090□4B11AL□-D□□□□-0□□
1.1	1435	20.7	507	C71	71	69.4	430	0.85	MB/EC	F304□□-C71-D□□□-□□090□4B11AL□-D□□□□-0□□
1.1	1435	25.4	412	C56	56	56.4	700	1.7	MB/EC	F305□□-C56-D□□□-□□090□4B11AL□-D□□□□-0□□
1.1	1435	23.1	453	C63	63	62.0	700	1.55	MB/EC	F305□□-C63-D□□□-□□090□4B11AL□-D□□□□-0□□
1.1	1435	20.5	510	C71	71	69.9	700	1.37	MB/EC	F305□□-C71-D□□□-□□090□4B11AL□-D□□□□-0□□
1.1	1435	19.2	545	C80	80	74.7	700	1.28	MB/EC	F305□□-C80-D□□□-□□090□4B11AL□-D□□□□-0□□
1.1	1435	20.9	502	C71	71	68.8	900	1.79	MB/EC	F306□□-C71-D□□□-□□090□4B11AL□-D□□□□-0□□
1.1	1435	19	553	C80	80	75.7	900	1.63	MB/EC	F306□□-C80-D□□□-□□090□4B11AL□-D□□□□-0□□
1.1	1435	16.7	627	C90	90	85.9	900	1.44	MB/EC	F306□□-C90-D□□□-□□090□4B11AL□-D□□□□-0□□
1.1	1435	15.3	685	D10	100	93.9	900	1.31	MB/EC	F306□□-D10-D□□□-□□090□4B11AL□-D□□□□-0□□
1.1	1435	12.6	829	D11	112	113.6	900	1.09	MB/EC	F306□□-D11-D□□□-□□090□4B11AL□-D□□□□-0□□

马达 额定功率	马达 额定转速	减速机实际 输出转速	减速机实际 输出扭矩	减速机公称 减速比代号	减速机公称 减速比	减速机精确 减速比	减速机额定 输出扭矩	服务系数	通讯方式	订货号
Motor Rated Power	Motor Rated Speed	Actual Output Speed of Gearmotor	Actual Output Torque of Gearmotor	Nominal Ratio Code of Gearmotor	Nominal Ratio of Gearmotor	Exact Ratio of Gearmotor	Normal Output Torque of Gearmotor	Service Coefficient	Communication Mode	Order Code
P _{IN} (kw)	n _{IN} (r/min)	n _{2N} (r/min)	T ₂ (N.m)	Code	i _N	i _{ex}	T _{2N} (N.m)	f		
1.5	1435	363	40	B40	4	3.95	130	3.25	MB/EC	F202□□-B40-D□□□-□□090□4B15AL□-D□□□□-0□□
1.5	1435	322	45	B45	4.5	4.46	140	3.11	MB/EC	F202□□-B45-D□□□-□□090□4B15AL□-D□□□□-0□□
1.5	1435	282	51	B50	5	5.08	140	2.75	MB/EC	F202□□-B50-D□□□-□□090□4B15AL□-D□□□□-0□□
1.5	1435	250	57	B56	5.6	5.74	150	2.63	MB/EC	F202□□-B56-D□□□-□□090□4B15AL□-D□□□□-0□□
1.5	1435	221	65	B63	6.3	6.50	150	2.31	MB/EC	F202□□-B63-D□□□-□□090□4B15AL□-D□□□□-0□□
1.5	1435	205	70	B71	7.1	7.00	150	2.14	MB/EC	F202□□-B71-D□□□-□□090□4B15AL□-D□□□□-0□□
1.5	1435	184	78	B80	8	7.80	150	1.92	MB/EC	F202□□-B80-D□□□-□□090□4B15AL□-D□□□□-0□□
1.5	1435	163	88	B90	9	8.79	150	1.7	MB/EC	F202□□-B90-D□□□-□□090□4B15AL□-D□□□□-0□□
1.5	1435	144	100	C10	10	10.0	150	1.5	MB/EC	F202□□-C10-D□□□-□□090□4B15AL□-D□□□□-0□□
1.5	1435	127	113	C11	11.2	11.3	150	1.33	MB/EC	F202□□-C11-D□□□-□□090□4B15AL□-D□□□□-0□□
1.5	1435	112	128	C13	12.5	12.8	150	1.17	MB/EC	F202□□-C13-D□□□-□□090□4B15AL□-D□□□□-0□□
1.5	1435	104	138	C14	14	13.8	150	1.09	MB/EC	F202□□-C14-D□□□-□□090□4B15AL□-D□□□□-0□□
1.5	1435	89.7	160	C16	16	16.0	150	0.94	MB/EC	F302□□-C16-D□□□-□□090□4B15AL□-D□□□□-0□□
1.5	1435	81.1	177	C18	18	17.7	150	0.85	MB/EC	F302□□-C18-D□□□-□□090□4B15AL□-D□□□□-0□□
1.5	1435	98.3	146	C14	14	14.6	240	1.64	MB/EC	F203□□-C14-D□□□-□□090□4B15AL□-D□□□□-0□□
1.5	1435	89.7	160	C16	16	16.0	240	1.5	MB/EC	F203□□-C16-D□□□-□□090□4B15AL□-D□□□□-0□□
1.5	1435	79.7	180	C18	18	18.0	240	1.33	MB/EC	F203□□-C18-D□□□-□□090□4B15AL□-D□□□□-0□□
1.5	1435	74.4	193	C20	20	19.3	240	1.24	MB/EC	F203□□-C20-D□□□-□□090□4B15AL□-D□□□□-0□□
1.5	1435	63.8	225	C22	22.4	22.5	240	1.07	MB/EC	F303□□-C22-D□□□-□□090□4B15AL□-D□□□□-0□□
1.5	1435	56.3	255	C25	25	25.5	240	0.94	MB/EC	F303□□-C25-D□□□-□□090□4B15AL□-D□□□□-0□□
1.5	1435	49.7	289	C28	28	28.9	240	0.83	MB/EC	F303□□-C28-D□□□-□□090□4B15AL□-D□□□□-0□□
1.5	1435	66.4	216	C22	22.4	21.6	440	2.04	MB/EC	F204□□-C22-D□□□-□□090□4B15AL□-D□□□□-0□□
1.5	1435	59.1	243	C25	25	24.3	440	1.81	MB/EC	F304□□-C25-D□□□-□□090□4B15AL□-D□□□□-0□□
1.5	1435	52.6	273	C28	28	27.3	480	1.76	MB/EC	F304□□-C28-D□□□-□□090□4B15AL□-D□□□□-0□□
1.5	1435	46.6	308	C32	31.5	30.8	480	1.56	MB/EC	F304□□-C32-D□□□-□□090□4B15AL□-D□□□□-0□□
1.5	1435	42	342	C36	35.5	34.2	480	1.4	MB/EC	F304□□-C36-D□□□-□□090□4B15AL□-D□□□□-0□□
1.5	1435	36.6	392	C40	40	39.2	480	1.22	MB/EC	F304□□-C40-D□□□-□□090□4B15AL□-D□□□□-0□□
1.5	1435	33.4	430	C45	45	43.0	420	0.98	MB/EC	F304□□-C45-D□□□-□□090□4B15AL□-D□□□□-0□□
1.5	1435	29.7	483	C50	50	48.3	420	0.87	MB/EC	F304□□-C50-D□□□-□□090□4B15AL□-D□□□□-0□□
1.5	1435	32.3	444	C45	45	44.4	700	1.58	MB/EC	F305□□-C45-D□□□-□□090□4B15AL□-D□□□□-0□□
1.5	1435	29.2	492	C50	50	49.2	700	1.42	MB/EC	F305□□-C50-D□□□-□□090□4B15AL□-D□□□□-0□□
1.5	1435	25.4	564	C56	56	56.4	700	1.24	MB/EC	F305□□-C56-D□□□-□□090□4B15AL□-D□□□□-0□□
1.5	1435	23.1	620	C63	63	62.0	700	1.13	MB/EC	F305□□-C63-D□□□-□□090□4B15AL□-D□□□□-0□□
1.5	1435	20.5	699	C71	71	69.9	700	1	MB/EC	F305□□-C71-D□□□-□□090□4B15AL□-D□□□□-0□□
1.5	1435	19.2	747	C80	80	74.7	700	0.94	MB/EC	F305□□-C80-D□□□-□□090□4B15AL□-D□□□□-0□□
1.5	1435	25.9	553	C56	56	55.3	900	1.63	MB/EC	F306□□-C56-D□□□-□□090□4B15AL□-D□□□□-0□□
1.5	1435	23.2	618	C63	63	61.8	900	1.46	MB/EC	F306□□-C63-D□□□-□□090□4B15AL□-D□□□□-0□□
1.5	1435	20.9	688	C71	71	68.8	900	1.31	MB/EC	F306□□-C71-D□□□-□□090□4B15AL□-D□□□□-0□□
1.5	1435	19	757	C80	80	75.7	900	1.19	MB/EC	F306□□-C80-D□□□-□□090□4B15AL□-D□□□□-0□□
1.5	1435	16.7	859	C90	90	85.9	900	1.05	MB/EC	F306□□-C90-D□□□-□□090□4B15AL□-D□□□□-0□□
1.5	1435	15.3	939	D10	100	93.9	900	0.96	MB/EC	F306□□-D10-D□□□-□□090□4B15AL□-D□□□□-0□□
1.5	1435	16.1	893	C90	90	89.3	1700	1.9	MB/EC	F307□□-C90-D□□□-□□090□4B15AL□-D□□□□-0□□
1.5	1435	14.7	978	D10	100	97.8	1700	1.74	MB/EC	F307□□-D10-D□□□-□□090□4B15AL□-D□□□□-0□□
1.5	1435	13.5	1064	D11	112	106.4	1700	1.6	MB/EC	F307□□-D11-D□□□-□□090□4B15AL□-D□□□□-0□□
1.5	1435	12	1196	D13	125	119.6	1700	1.42	MB/EC	F307□□-D13-D□□□-□□090□4B15AL□-D□□□□-0□□
1.5	1435	11	1310	D14	140	131.0	1700	1.3	MB/EC	F307□□-D14-D□□□-□□090□4B15AL□-D□□□□-0□□
1.5	1435	9.3	1538	D16	160	153.8	1700	1.11	MB/EC	F307□□-D16-D□□□-□□090□4B15AL□-D□□□□-0□□

马达 额定功率	马达 额定转速	减速机实际 输出转速	减速机实际 输出扭矩	减速机公称 减速比代号	减速机公称 减速比	减速机精确 减速比	减速机额定 输出扭矩	服务系数	通讯方式	订货号
Motor Rated Power	Motor Rated Speed	Actual Output Speed of Gearmotor	Actual Output Torque of Gearmotor	Nominal Ratio Code of Gearmotor	Nominal Ratio of Gearmotor	Exact Ratio of Gearmotor	Normal Output Torque of Gearmotor	Service Coefficient	Communication Mode	Order Code
P _{1N} (kw)	n _{1N} (r/min)	n _{2N} (r/min)	T ₂ (N.m)	Code	i _N	i _{ex}	T _{2N} (N.m)	f		
2.2	1455	352	59	B40	4	4.13	160	2.71	MB/EC	F203□□-B40-D□□□-□□100□4B22AL□-D□□□□-0□□
2.2	1455	314	67	B45	4.5	4.63	170	2.54	MB/EC	F203□□-B45-D□□□-□□100□4B22AL□-D□□□□-0□□
2.2	1455	278	75	B50	5	5.23	185	2.47	MB/EC	F203□□-B50-D□□□-□□100□4B22AL□-D□□□□-0□□
2.2	1455	250	84	B56	5.6	5.81	220	2.62	MB/EC	F203□□-B56-D□□□-□□100□4B22AL□-D□□□□-0□□
2.2	1455	218	96	B63	6.3	6.66	220	2.29	MB/EC	F203□□-B63-D□□□-□□100□4B22AL□-D□□□□-0□□
2.2	1455	199	105	B71	7.1	7.32	220	2.1	MB/EC	F203□□-B71-D□□□-□□100□4B22AL□-D□□□□-0□□
2.2	1455	176	119	B80	8	8.25	220	1.85	MB/EC	F203□□-B80-D□□□-□□100□4B22AL□-D□□□□-0□□
2.2	1455	161	130	B90	9	9.03	220	1.69	MB/EC	F203□□-B90-D□□□-□□100□4B22AL□-D□□□□-0□□
2.2	1455	144	145	C10	10	10.1	220	1.52	MB/EC	F203□□-C10-D□□□-□□100□4B22AL□-D□□□□-0□□
2.2	1455	128	164	C11	11.2	11.4	220	1.34	MB/EC	F203□□-C11-D□□□-□□100□4B22AL□-D□□□□-0□□
2.2	1455	115	183	C13	12.5	12.7	220	1.2	MB/EC	F203□□-C13-D□□□-□□100□4B22AL□-D□□□□-0□□
2.2	1455	99.7	210	C14	14	14.6	240	1.14	MB/EC	F203□□-C14-D□□□-□□100□4B22AL□-D□□□□-0□□
2.2	1455	90.9	230	C16	16	16.0	240	1.04	MB/EC	F203□□-C16-D□□□-□□100□4B22AL□-D□□□□-0□□
2.2	1455	80.8	259	C18	18	18.0	240	0.93	MB/EC	F203□□-C18-D□□□-□□100□4B22AL□-D□□□□-0□□
2.2	1455	75.4	278	C20	20	19.3	240	0.86	MB/EC	F203□□-C20-D□□□-□□100□4B22AL□-D□□□□-0□□
2.2	1455	95.1	220	C16	16	15.3	410	1.86	MB/EC	F204□□-C16-D□□□-□□100□4B22AL□-D□□□□-0□□
2.2	1455	83.6	251	C18	18	17.4	410	1.63	MB/EC	F204□□-C18-D□□□-□□100□4B22AL□-D□□□□-0□□
2.2	1455	76.6	274	C20	20	19.0	410	1.5	MB/EC	F204□□-C20-D□□□-□□100□4B22AL□-D□□□□-0□□
2.2	1455	67.4	311	C22	22.4	21.6	440	1.41	MB/EC	F204□□-C22-D□□□-□□100□4B22AL□-D□□□□-0□□
2.2	1455	59.9	350	C25	25	24.3	440	1.26	MB/EC	F304□□-C25-D□□□-□□100□4B22AL□-D□□□□-0□□
2.2	1455	53.3	393	C28	28	27.3	480	1.22	MB/EC	F304□□-C28-D□□□-□□100□4B22AL□-D□□□□-0□□
2.2	1455	47.2	444	C32	31.5	30.8	480	1.08	MB/EC	F304□□-C32-D□□□-□□100□4B22AL□-D□□□□-0□□
2.2	1455	42.5	492	C36	35.5	34.2	480	0.98	MB/EC	F304□□-C36-D□□□-□□100□4B22AL□-D□□□□-0□□
2.2	1455	37.1	564	C40	40	39.2	480	0.85	MB/EC	F304□□-C40-D□□□-□□100□4B22AL□-D□□□□-0□□
2.2	1455	45.6	459	C32	31.5	31.9	700	1.53	MB/EC	F305□□-C32-D□□□-□□100□4B22AL□-D□□□□-0□□
2.2	1455	41.6	504	C36	35.5	35.0	700	1.39	MB/EC	F305□□-C36-D□□□-□□100□4B22AL□-D□□□□-0□□
2.2	1455	37	566	C40	40	39.3	700	1.24	MB/EC	F305□□-C40-D□□□-□□100□4B22AL□-D□□□□-0□□
2.2	1455	32.8	639	C45	45	44.4	700	1.1	MB/EC	F305□□-C45-D□□□-□□100□4B22AL□-D□□□□-0□□
2.2	1455	29.6	708	C50	50	49.2	700	0.99	MB/EC	F305□□-C50-D□□□-□□100□4B22AL□-D□□□□-0□□
2.2	1455	25.8	812	C56	56	56.4	700	0.86	MB/EC	F305□□-C56-D□□□-□□100□4B22AL□-D□□□□-0□□
2.2	1455	35.4	592	C40	40	41.1	900	1.52	MB/EC	F306□□-C40-D□□□-□□100□4B22AL□-D□□□□-0□□
2.2	1455	31.6	662	C45	45	46.0	900	1.36	MB/EC	F306□□-C45-D□□□-□□100□4B22AL□-D□□□□-0□□
2.2	1455	28.4	737	C50	50	51.2	900	1.22	MB/EC	F306□□-C50-D□□□-□□100□4B22AL□-D□□□□-0□□
2.2	1455	26.3	796	C56	56	55.3	900	1.13	MB/EC	F306□□-C56-D□□□-□□100□4B22AL□-D□□□□-0□□
2.2	1455	23.5	890	C63	63	61.8	900	1.01	MB/EC	F306□□-C63-D□□□-□□100□4B22AL□-D□□□□-0□□
2.2	1455	21.1	991	C71	71	68.8	900	0.91	MB/EC	F306□□-C71-D□□□-□□100□4B22AL□-D□□□□-0□□
2.2	1455	19.2	1090	C80	80	75.7	900	0.83	MB/EC	F306□□-C80-D□□□-□□100□4B22AL□-D□□□□-0□□
2.2	1455	22.8	919	C63	63	63.8	1700	1.85	MB/EC	F307□□-C63-D□□□-□□100□4B22AL□-D□□□□-0□□
2.2	1455	20.3	1032	C71	71	71.7	1700	1.65	MB/EC	F307□□-C71-D□□□-□□100□4B22AL□-D□□□□-0□□
2.2	1455	18.1	1155	C80	80	80.2	1700	1.47	MB/EC	F307□□-C80-D□□□-□□100□4B22AL□-D□□□□-0□□
2.2	1455	16.3	1286	C90	90	89.3	1700	1.32	MB/EC	F307□□-C90-D□□□-□□100□4B22AL□-D□□□□-0□□
2.2	1455	14.9	1408	D10	100	97.8	1700	1.21	MB/EC	F307□□-D10-D□□□-□□100□4B22AL□-D□□□□-0□□
2.2	1455	13.7	1532	D11	112	106.4	1700	1.11	MB/EC	F307□□-D11-D□□□-□□100□4B22AL□-D□□□□-0□□
2.2	1455	12.2	1722	D13	125	119.6	1700	0.99	MB/EC	F307□□-D13-D□□□-□□100□4B22AL□-D□□□□-0□□
2.2	1455	11.1	1886	D14	140	131.0	1700	0.9	MB/EC	F307□□-D14-D□□□-□□100□4B22AL□-D□□□□-0□□
2.2	1455	10.9	1918	D13	125	133.2	3500	1.82	MB/EC	F308□□-D13-D□□□-□□100□4B22AL□-D□□□□-0□□
2.2	1455	9.8	2131	D14	140	148.0	3500	1.64	MB/EC	F308□□-D14-D□□□-□□100□4B22AL□-D□□□□-0□□
2.2	1455	8.7	2396	D16	160	166.4	3500	1.46	MB/EC	F308□□-D16-D□□□-□□100□4B22AL□-D□□□□-0□□
2.2	1455	7.9	2637	D18	180	183.1	3500	1.33	MB/EC	F308□□-D18-D□□□-□□100□4B22AL□-D□□□□-0□□
2.2	1455	7.3	2881	D20	200	200.1	3500	1.21	MB/EC	F308□□-D20-D□□□-□□100□4B22AL□-D□□□□-0□□

马达 额定功率	马达 额定转速	减速机实际 输出转速	减速机实际 输出扭矩	减速机公称 减速比代号	减速机公称 减速比	减速机精确 减速比	减速机额定 输出扭矩	服务系数	通讯方式	订货号
Motor Rated Power	Motor Rated Speed	Actual Output Speed of Gearmotor	Actual Output Torque of Gearmotor	Nominal Ratio Code of Gearmotor	Nominal Ratio of Gearmotor	Exact Ratio of Gearmotor	Normal Output Torque of Gearmotor	Service Coefficient	Communication Mode	Order Code
P _{IN} (kw)	n _{IN} (r/min)	n _{2N} (r/min)	T ₂ (N.m)	Code	i _N	i _{ex}	T _{2N} (N.m)	f		
3	1455	352	81	B40	4	4.13	160	1.98	MB/EC	F203□□-B40-D□□□-□□100□4B30AL□-D□□□□-0□□
3	1455	314	91	B45	4.5	4.63	170	1.87	MB/EC	F203□□-B45-D□□□-□□100□4B30AL□-D□□□□-0□□
3	1455	278	103	B50	5	5.23	185	1.8	MB/EC	F203□□-B50-D□□□-□□100□4B30AL□-D□□□□-0□□
3	1455	250	114	B56	5.6	5.81	220	1.93	MB/EC	F203□□-B56-D□□□-□□100□4B30AL□-D□□□□-0□□
3	1455	218	131	B63	6.3	6.66	220	1.68	MB/EC	F203□□-B63-D□□□-□□100□4B30AL□-D□□□□-0□□
3	1455	199	144	B71	7.1	7.32	220	1.53	MB/EC	F203□□-B71-D□□□-□□100□4B30AL□-D□□□□-0□□
3	1455	176	163	B80	8	8.25	220	1.35	MB/EC	F203□□-B80-D□□□-□□100□4B30AL□-D□□□□-0□□
3	1455	161	178	B90	9	9.03	220	1.24	MB/EC	F203□□-B90-D□□□-□□100□4B30AL□-D□□□□-0□□
3	1455	144	199	C10	10	10.1	220	1.11	MB/EC	F203□□-C10-D□□□-□□100□4B30AL□-D□□□□-0□□
3	1455	128	225	C11	11.2	11.4	220	0.98	MB/EC	F203□□-C11-D□□□-□□100□4B30AL□-D□□□□-0□□
3	1455	115	250	C13	12.5	12.7	220	0.88	MB/EC	F203□□-C13-D□□□-□□100□4B30AL□-D□□□□-0□□
3	1455	99.7	288	C14	14	14.6	240	0.83	MB/EC	F203□□-C14-D□□□-□□100□4B30AL□-D□□□□-0□□
3	1455	130	221	C11	11.2	11.2	410	1.86	MB/EC	F204□□-C11-D□□□-□□100□4B30AL□-D□□□□-0□□
3	1455	116	246	C13	12.5	12.5	410	1.67	MB/EC	F204□□-C13-D□□□-□□100□4B30AL□-D□□□□-0□□
3	1455	105	274	C14	14	13.9	410	1.5	MB/EC	F204□□-C14-D□□□-□□100□4B30AL□-D□□□□-0□□
3	1455	95.1	301	C16	16	15.3	410	1.36	MB/EC	F204□□-C16-D□□□-□□100□4B30AL□-D□□□□-0□□
3	1455	83.6	343	C18	18	17.4	410	1.2	MB/EC	F204□□-C18-D□□□-□□100□4B30AL□-D□□□□-0□□
3	1455	76.6	374	C20	20	19.0	410	1.1	MB/EC	F204□□-C20-D□□□-□□100□4B30AL□-D□□□□-0□□
3	1455	67.4	426	C22	22.4	21.6	440	1.03	MB/EC	F204□□-C22-D□□□-□□100□4B30AL□-D□□□□-0□□
3	1455	59.9	479	C25	25	24.3	440	0.92	MB/EC	F304□□-C25-D□□□-□□100□4B30AL□-D□□□□-0□□
3	1455	53.3	538	C28	28	27.3	480	0.89	MB/EC	F304□□-C28-D□□□-□□100□4B30AL□-D□□□□-0□□
3	1455	65.5	437	C22	22.4	22.2	680	1.56	MB/EC	F305□□-C22-D□□□-□□100□4B30AL□-D□□□□-0□□
3	1455	58	494	C25	25	25.1	680	1.38	MB/EC	F305□□-C25-D□□□-□□100□4B30AL□-D□□□□-0□□
3	1455	52.3	548	C28	28	27.8	700	1.28	MB/EC	F305□□-C28-D□□□-□□100□4B30AL□-D□□□□-0□□
3	1455	45.6	628	C32	31.5	31.9	700	1.11	MB/EC	F305□□-C32-D□□□-□□100□4B30AL□-D□□□□-0□□
3	1455	41.6	690	C36	35.5	35.0	700	1.01	MB/EC	F305□□-C36-D□□□-□□100□4B30AL□-D□□□□-0□□
3	1455	37	774	C40	40	39.3	700	0.9	MB/EC	F305□□-C40-D□□□-□□100□4B30AL□-D□□□□-0□□
3	1455	32.8	875	C45	45	44.4	700	0.8	MB/EC	F305□□-C45-D□□□-□□100□4B30AL□-D□□□□-0□□
3	1455	54.3	528	C28	28	26.8	900	1.7	MB/EC	F306□□-C28-D□□□-□□100□4B30AL□-D□□□□-0□□
3	1455	46	623	C32	31.5	31.6	900	1.44	MB/EC	F306□□-C32-D□□□-□□100□4B30AL□-D□□□□-0□□
3	1455	40.2	713	C36	35.5	36.2	900	1.26	MB/EC	F306□□-C36-D□□□-□□100□4B30AL□-D□□□□-0□□
3	1455	35.4	810	C40	40	41.1	900	1.11	MB/EC	F306□□-C40-D□□□-□□100□4B30AL□-D□□□□-0□□
3	1455	31.6	906	C45	45	46.0	900	0.99	MB/EC	F306□□-C45-D□□□-□□100□4B30AL□-D□□□□-0□□
3	1455	28.4	1009	C50	50	51.2	900	0.89	MB/EC	F306□□-C50-D□□□-□□100□4B30AL□-D□□□□-0□□
3	1455	26.3	1089	C56	56	55.3	900	0.83	MB/EC	F306□□-C56-D□□□-□□100□4B30AL□-D□□□□-0□□
3	1455	32.8	875	C45	45	44.4	1700	1.94	MB/EC	F307□□-C45-D□□□-□□100□4B30AL□-D□□□□-0□□
3	1455	29.1	985	C50	50	50.0	1700	1.73	MB/EC	F307□□-C50-D□□□-□□100□4B30AL□-D□□□□-0□□
3	1455	26.2	1095	C56	56	55.6	1700	1.55	MB/EC	F307□□-C56-D□□□-□□100□4B30AL□-D□□□□-0□□
3	1455	22.8	1257	C63	63	63.8	1700	1.35	MB/EC	F307□□-C63-D□□□-□□100□4B30AL□-D□□□□-0□□
3	1455	20.3	1412	C71	71	71.7	1700	1.2	MB/EC	F307□□-C71-D□□□-□□100□4B30AL□-D□□□□-0□□
3	1455	18.1	1580	C80	80	80.2	1700	1.08	MB/EC	F307□□-C80-D□□□-□□100□4B30AL□-D□□□□-0□□
3	1455	16.3	1759	C90	90	89.3	1700	0.97	MB/EC	F307□□-C90-D□□□-□□100□4B30AL□-D□□□□-0□□
3	1455	14.9	1927	D10	100	97.8	1700	0.88	MB/EC	F307□□-D10-D□□□-□□100□4B30AL□-D□□□□-0□□
3	1455	13.7	2096	D11	112	106.4	1700	0.81	MB/EC	F307□□-D11-D□□□-□□100□4B30AL□-D□□□□-0□□
3	1455	15.3	1873	C90	90	95.1	3500	1.87	MB/EC	F308□□-C90-D□□□-□□100□4B30AL□-D□□□□-0□□
3	1455	14.3	1998	D10	100	101.4	3500	1.75	MB/EC	F308□□-D10-D□□□-□□100□4B30AL□-D□□□□-0□□
3	1455	12.4	2307	D11	112	117.1	3500	1.52	MB/EC	F308□□-D11-D□□□-□□100□4B30AL□-D□□□□-0□□
3	1455	10.9	2624	D13	125	133.2	3500	1.33	MB/EC	F308□□-D13-D□□□-□□100□4B30AL□-D□□□□-0□□
3	1455	9.8	2916	D14	140	148.0	3500	1.2	MB/EC	F308□□-D14-D□□□-□□100□4B30AL□-D□□□□-0□□
3	1455	8.7	3278	D16	160	166.4	3500	1.07	MB/EC	F308□□-D16-D□□□-□□100□4B30AL□-D□□□□-0□□
3	1455	7.9	3607	D18	180	183.1	3500	0.97	MB/EC	F308□□-D18-D□□□-□□100□4B30AL□-D□□□□-0□□
3	1455	7.3	3942	D20	200	200.1	3500	0.89	MB/EC	F308□□-D20-D□□□-□□100□4B30AL□-D□□□□-0□□

6.外形尺寸图(mm)

6. Dimensions (mm)

F202/F302

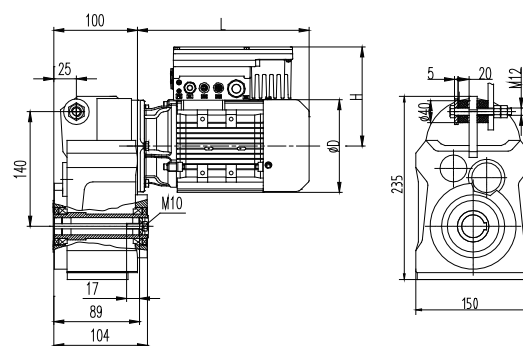
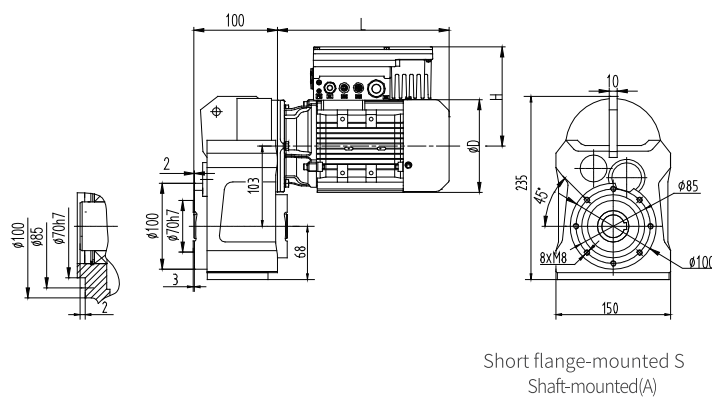
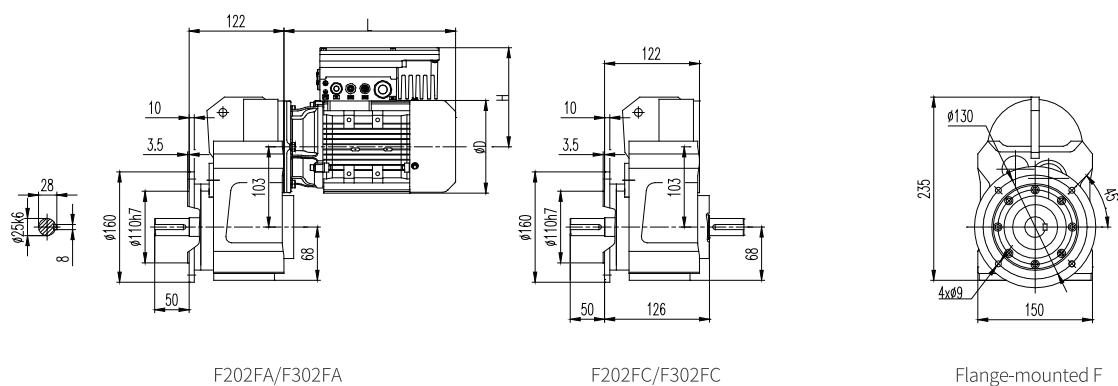
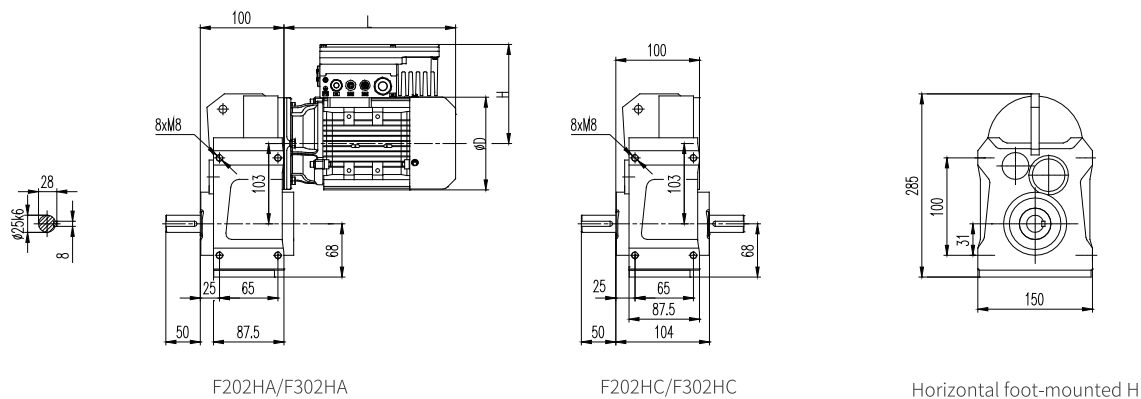

Dimension Data of Gearmotor Variable Frequency Drive
All-in-one (mm) 50Hz-1500r/min

Power of 4 pole type (kW)	Range of Ratio	MH			MP		
		L	D	H	L	D	H
0.25	4-112	223	138	151.5	223	138	151.5
0.37	4-71	223	138	151.5	223	138	151.5
0.55	4-50	299	159	173	299	159	173
0.75	4-35.5	299	159	173	299	159	173
1.1	4-25	321	176	188.5	321	176	188.5
1.5	4-18	321	176	188.5	346	176	188.5

F202/F302

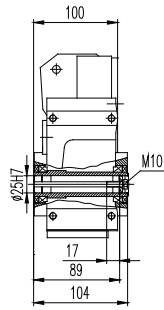
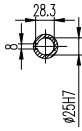

F202HG/F302HG

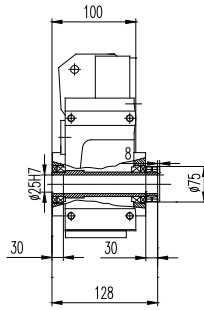

F202HI/F302HI

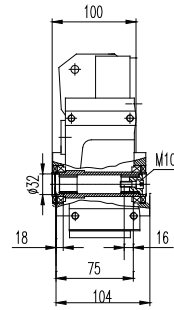

F202HK/F302HK

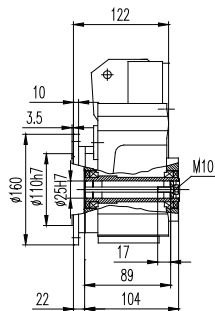
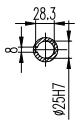

F202FG/F302FG

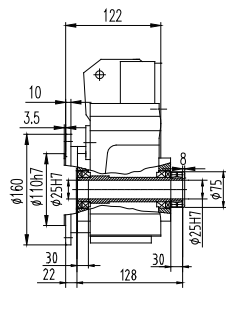

F202FI/F302FI

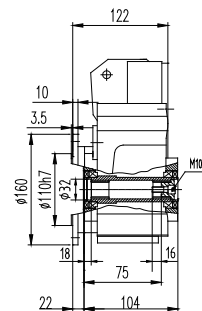

F202FK/F302FK

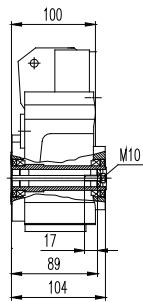
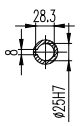

F202SG/F302SG
F202AG/F302AG

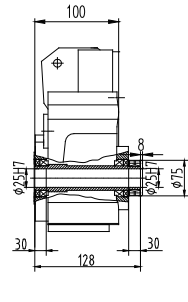

F202SI/F302SI
F202AI/F302AI

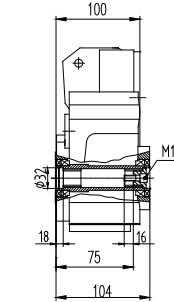

F202SK/F302SK
F202AK/F302AK

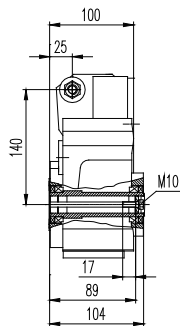
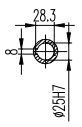

F202TG/F302TG

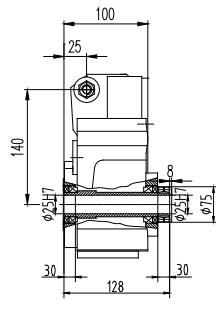

F202TI/F302TI

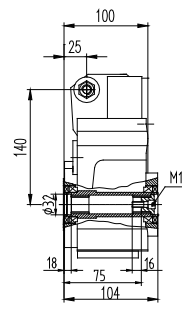

F202TK/F302TK

F203/F303

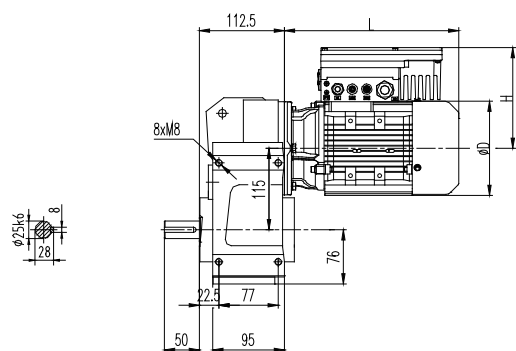

F203HA/F303HA

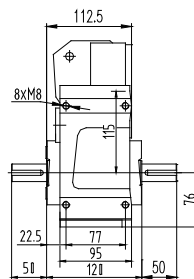

F203HC/F303HC

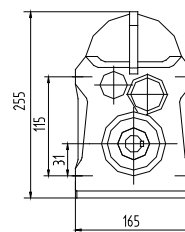

Horizontal foot-mounted H

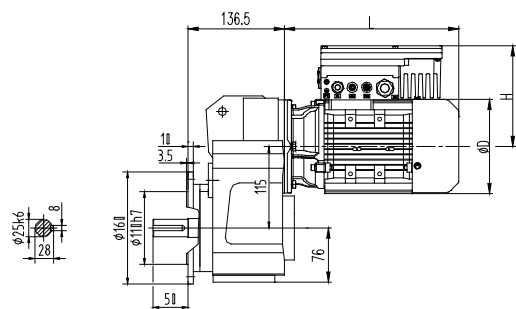

F203FA/F303FA

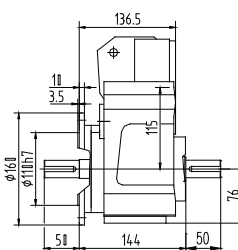

F203FC/F303FC

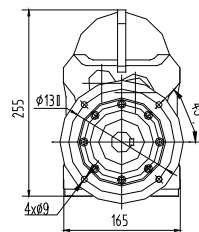

Flange-mounted F

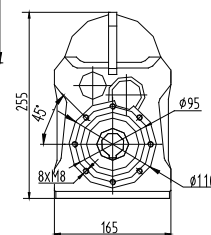
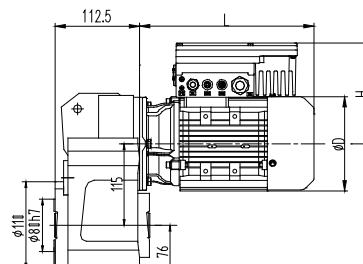
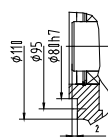

Short flange-mounted S
Shaft-mounted(A)

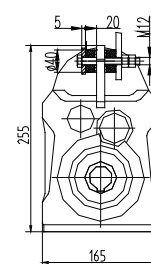
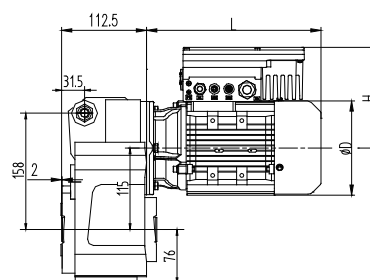

Torque arm-mounted with accessory T

Dimension Data of Gearmotor Variable Frequency Drive
All-in-one (mm) 50Hz-1500r/min

Power of 4 pole type (kW)	Range of Ratio	MH			MP		
		L	D	H	L	D	H
0.25	80-125	223	138	151.5	223	138	151.5
0.37	56-112	223	138	151.5	223	138	151.5
0.55	40-80	299	159	173	299	159	173
0.75	28-56	299	159	173	299	159	173
1.1	20-40	321	176	188.5	321	176	188.5
1.5	14-28	321	176	188.5	346	176	188.5
2.2	4-20	394	198	191	394	198	191
3	4-14	394	198	191	394	198	191

F203/F303

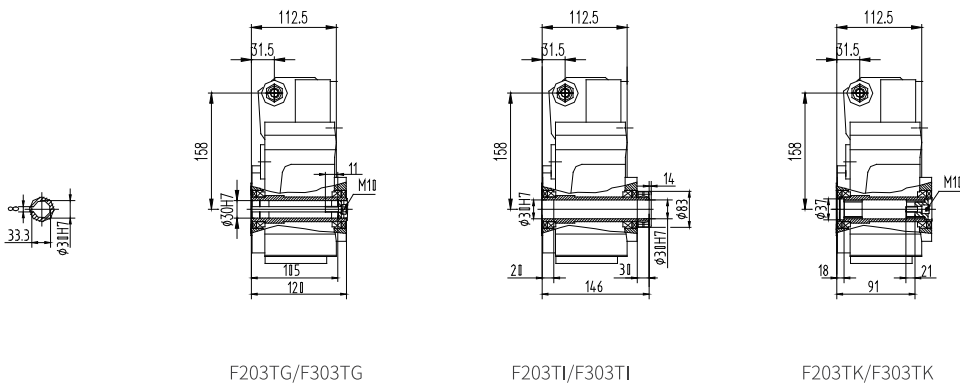
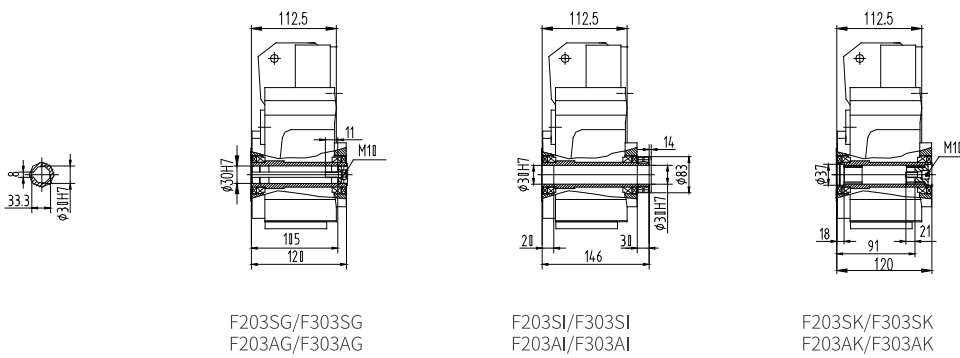
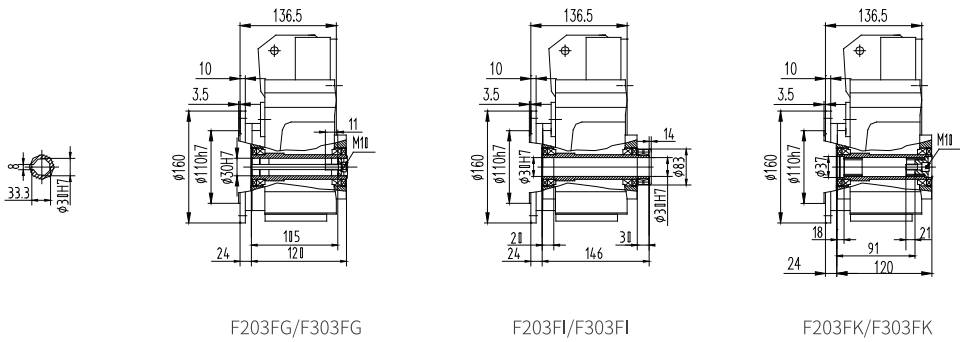
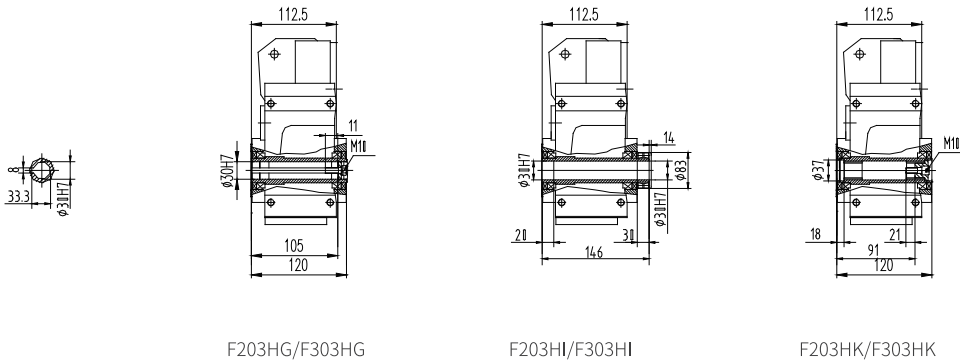

F204/F304

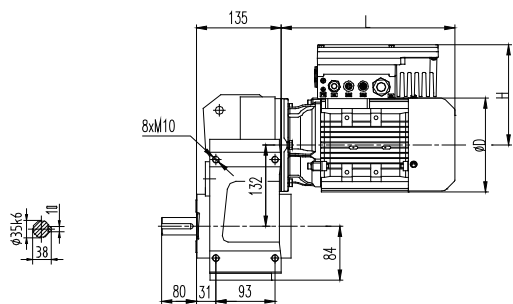

F204HA/F304HA

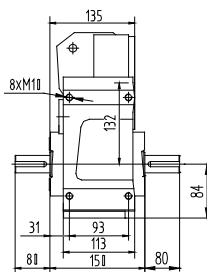

F204HC/F304HC

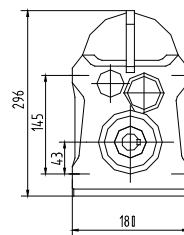

Horizontal foot-mounted H

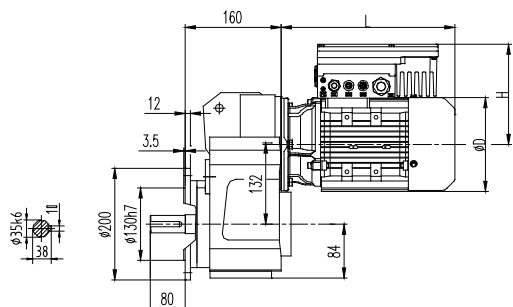

F204FA/F304FA

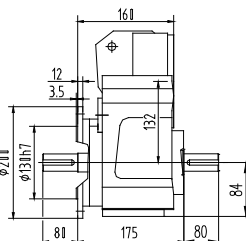

F204FC/F304FC

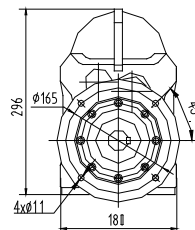

Flange-mounted F

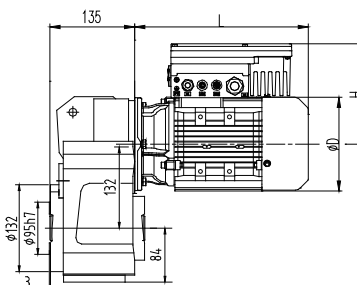
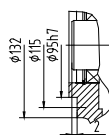

Short flange-mounted S
Shaft-mounted(A)

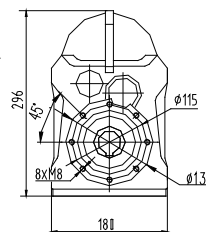

Torque arm-mounted with accessory T

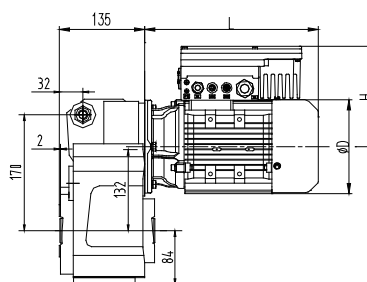

Dimension Data of Gearmotor Variable Frequency Drive All-in-one (mm) 50Hz-1500r/min								
Power of 4 pole type (kW)	Range of Ratio	MH			MP			H
		L	D	H	L	D	H	
0.37	100-160	224	138	151.5	224	138	151.5	
0.55	63-140	300	159	173	300	159	173	
0.75	50-112	300	159	173	300	159	173	
1.1	31.5-71	323	176	188.5	323	176	188.5	
1.5	22.4-50	323	176	188.5	348	176	188.5	
2.2	16-40	395	198	191	395	198	191	
3	11.2-28	395	198	191	395	198	191	

F204/F304

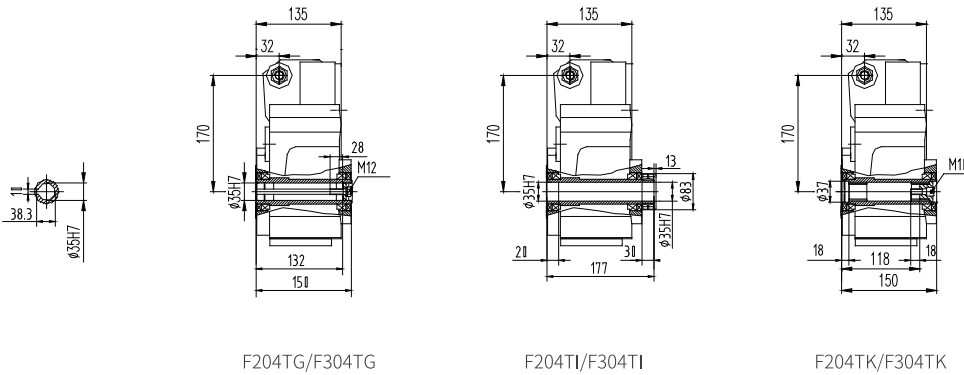
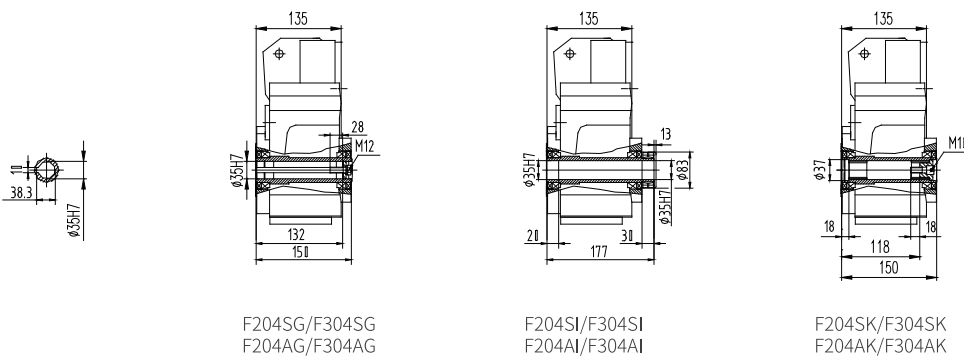
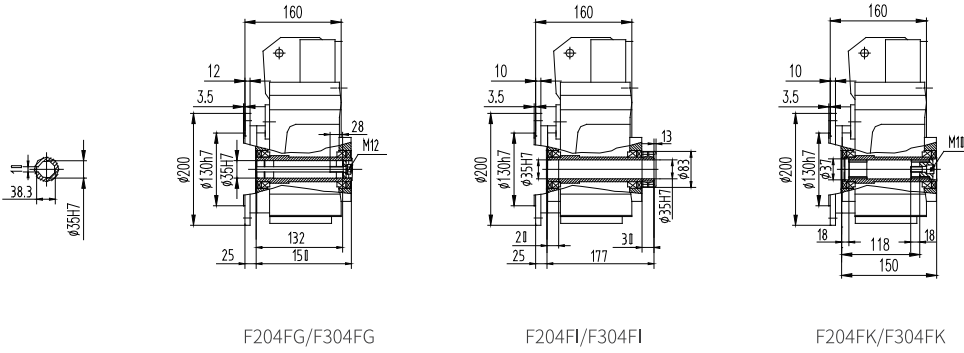
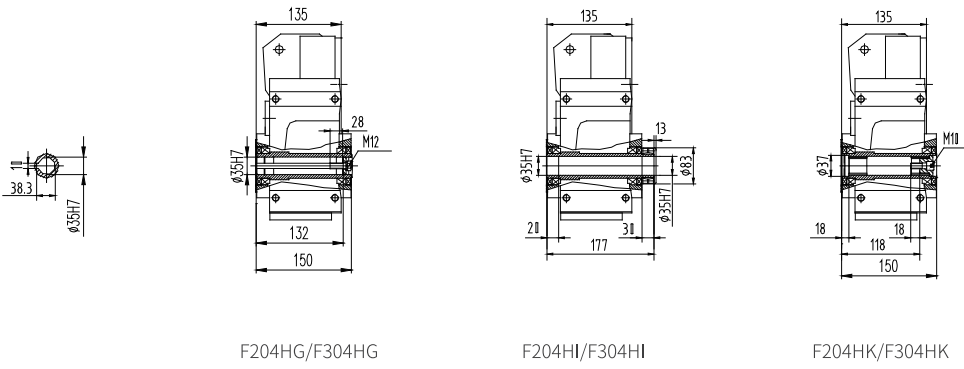

F205/F305

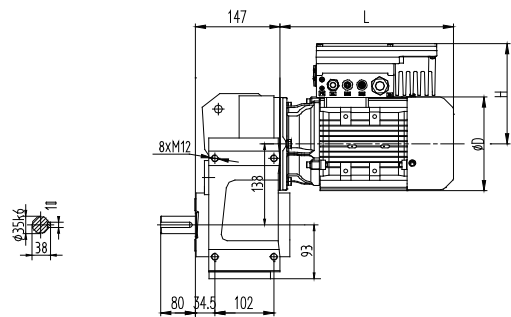

F205HA/F305HA

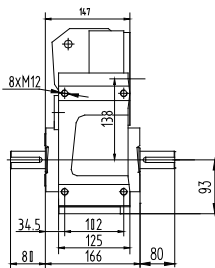

F205HC/F305HC

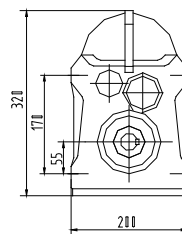

Horizontal foot-mounted H

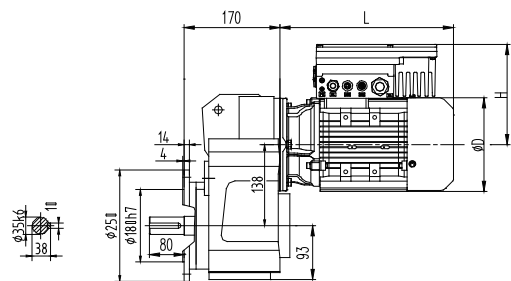

F205FA/F305FA

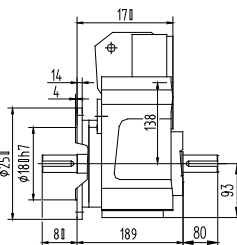

F205FC/F305FC

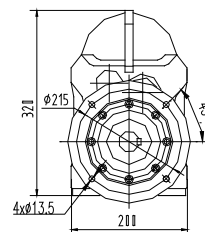

Flange-mounted F

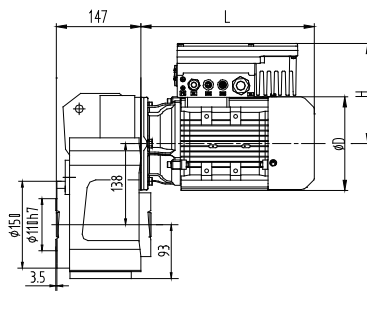
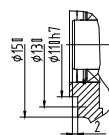

Short flange-mounted S
Shaft-mounted(A)

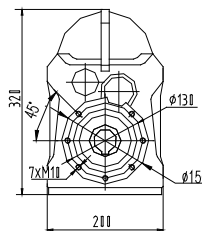

Torque arm-mounted with accessory T

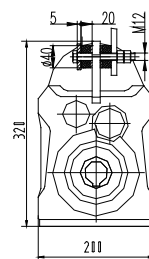
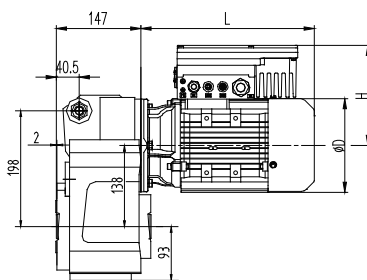

Dimension Data of Gearmotor Variable Frequency Drive All-in-one (mm) 50Hz-1500r/min							
Power of 4 pole type (kW)	Range of Ratio	MH			MP		
		L	D	H	L	D	H
0.55	112-140	300	159	173	300	159	173
0.75	90-140	300	159	173	300	159	173
1.1	56-80	323	176	188.5	323	176	188.5
1.5	45-80	323	176	188.5	348	176	188.5
2.2	31.5-56	395	198	191	395	198	191
3	22.4-45	395	198	191	395	198	191

F205/F305

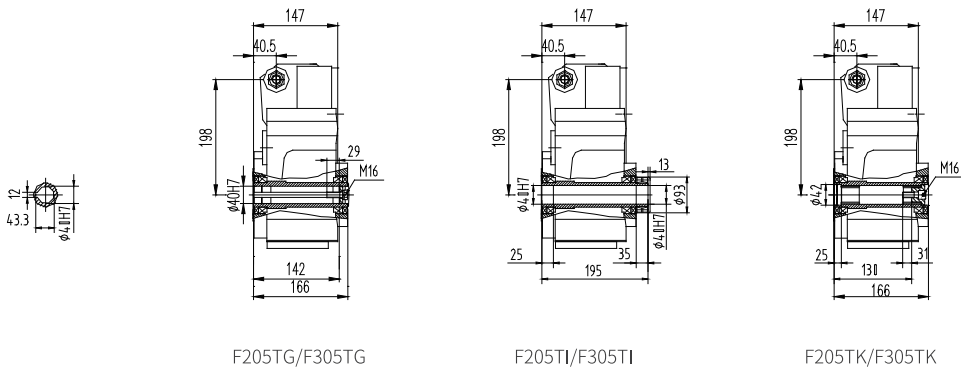
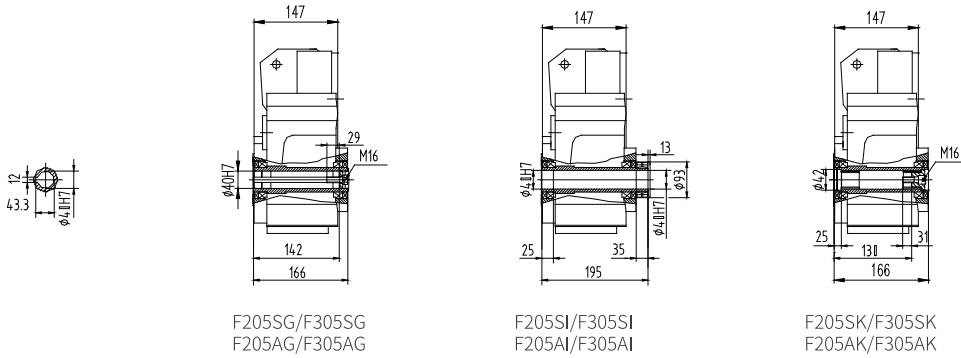
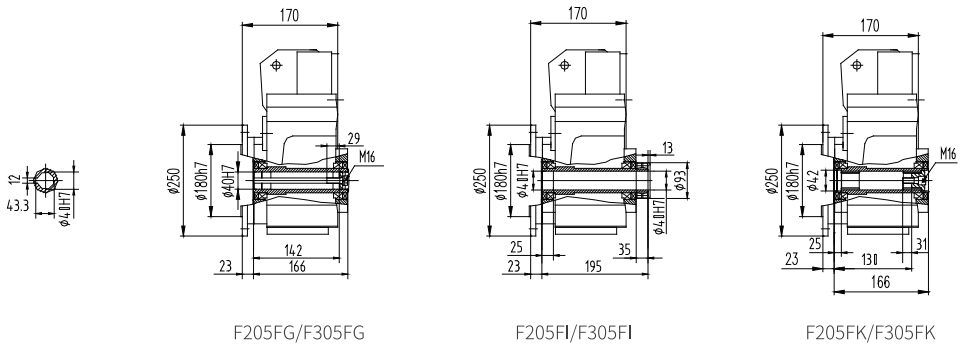
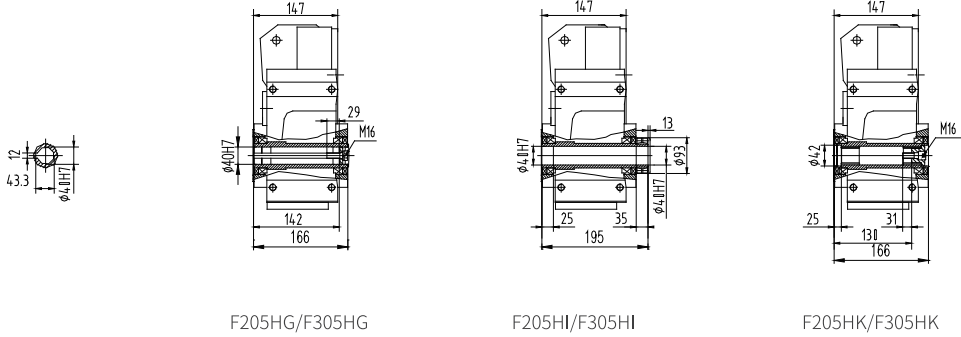

F206/F306

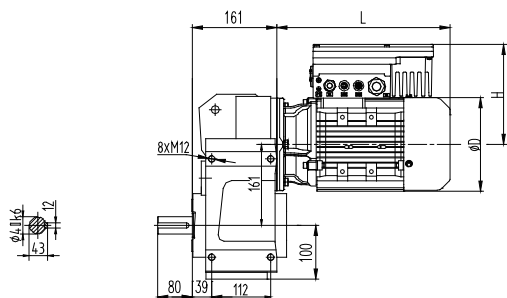

F206HA/F306HA

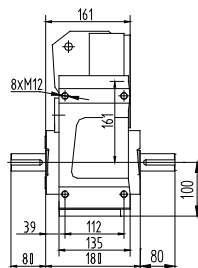

F206HC/F306HC

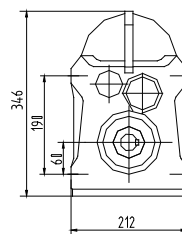

Horizontal foot-mounted H

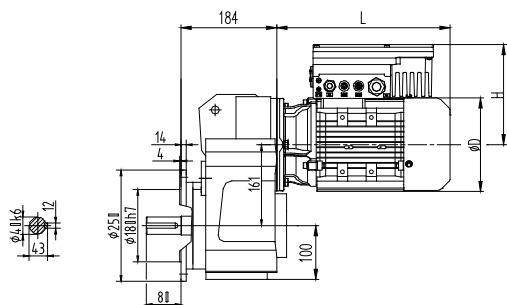

F206FA/F306FA

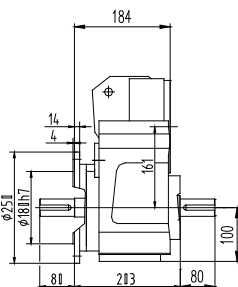

F206FC/F306FC

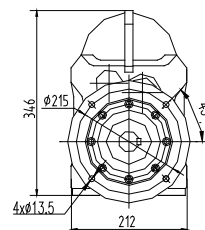

Flange-mounted F

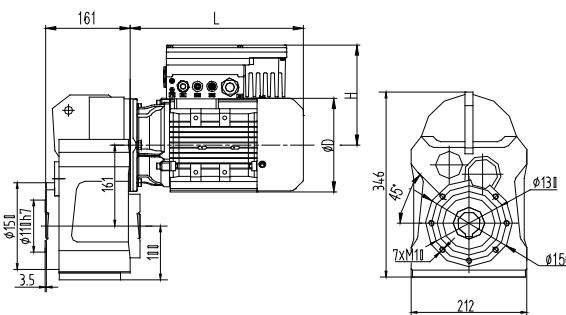
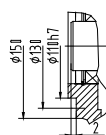

Short flange-mounted S
Shaft-mounted(A)

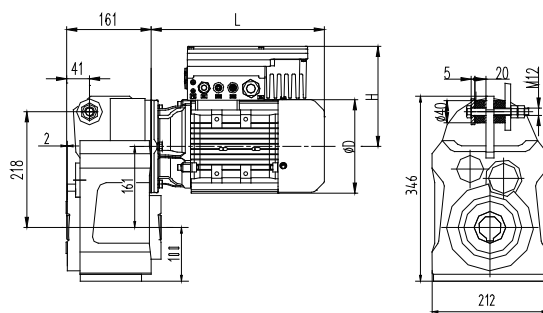

Torque arm-mounted with accessory T

Dimension Data of Gearmotor Variable Frequency Drive
All-in-one (mm) 50Hz-1500r/min

Power of 4 pole type (kW)	Range of Ratio	MH			MP		
		L	D	H	L	D	H
0.75	112-200	300	159	173	300	159	173
1.1	71-112	323	176	188.5	323	176	188.5
1.5	56-100	323	176	188.5	348	176	188.5
2.2	40-80	395	198	191	395	198	191
3	28-56	395	198	191	395	198	191

F206/F306

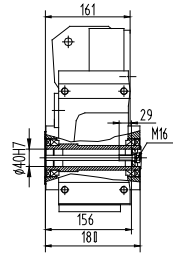
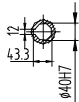

F206HG/F306HG

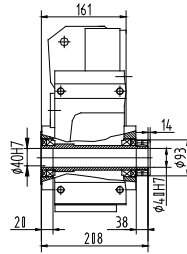

F206HI/F306HI

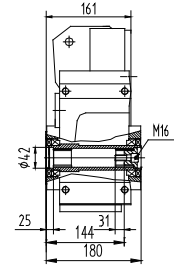

F206HK/F306HK

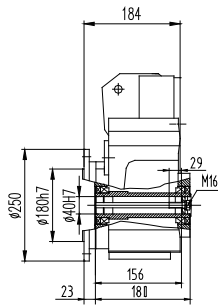

F206FG/F306FG

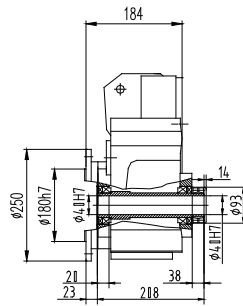

F206FI/F306FI

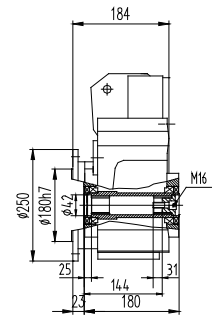

F206FK/F306FK

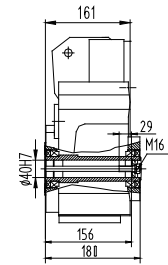

F206SG/F306SG
F206AG/F306AG

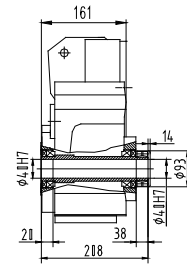

F206SI/F306SI
F206AI/F306AI

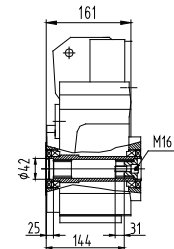

F206SK/F306SK
F206AK/F306AK

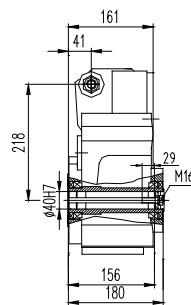

F206TG/F306TG

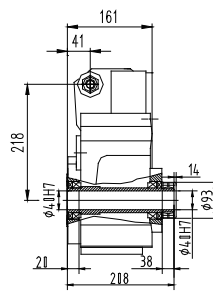

F206TI/F306TI

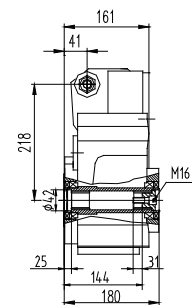

F206TK/F306TK

F207/F307

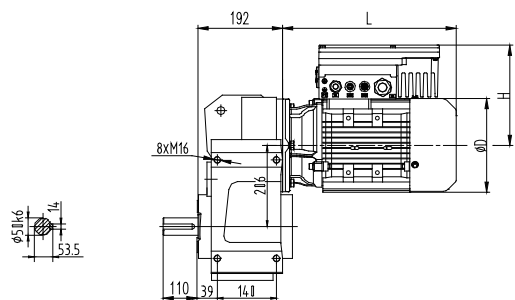

F207HA/F307HA

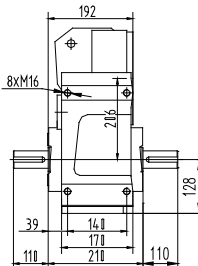

F207HC/F307HC

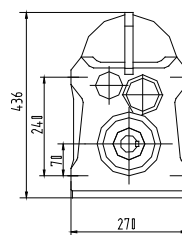

Horizontal foot-mounted H

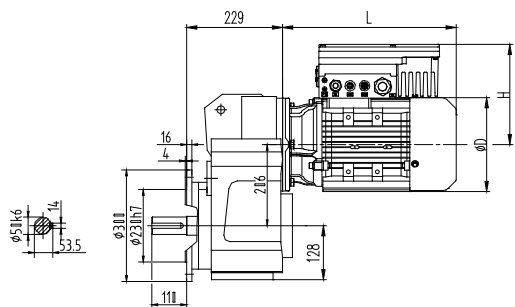

F207FA/F307FA

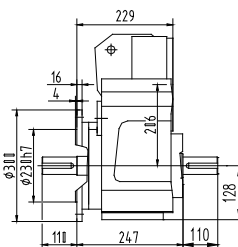

F207FC/F307FC

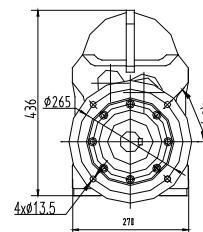

Flange-mounted F

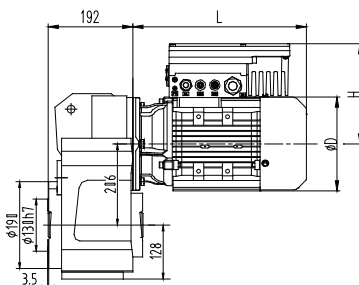
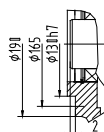

Short flange-mounted S
Shaft-mounted(A)

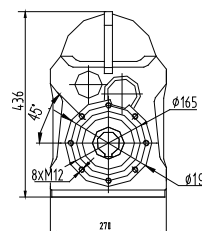

Torque arm-mounted with accessory T

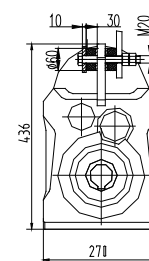
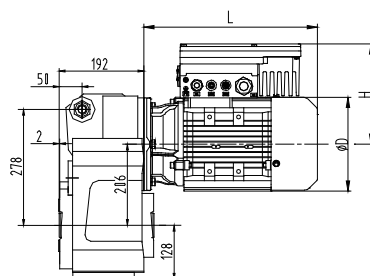

Dimension Data of Gearmotor Variable Frequency Drive All-in-one (mm) 50Hz-1500r/min							
Power of 4 pole type (kW)	Range of Ratio	MH			MP		
		L	D	H	L	D	H
1.5	90-160	314	176	188.5	339	176	188.5
2.2	63-140	387	198	191	387	198	191
3	45-112	387	198	191	387	198	191

F207/F307

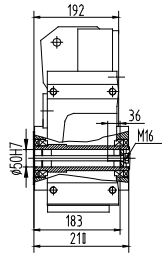

F207HG/F307HG

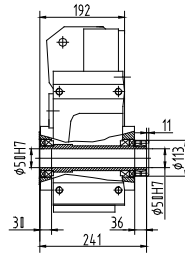

F207HI/F307HI

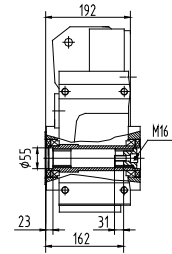

F207HK/F307HK

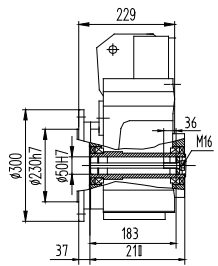

F207FG/F307FG

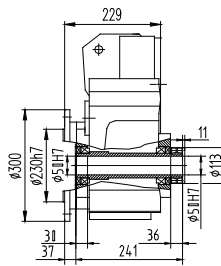

F207FI/F307FI

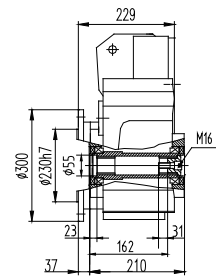

F207FK/F307FK

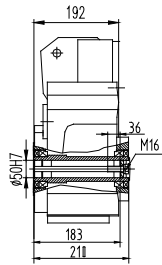

F207SG/F307SG
F207AG/F307AG

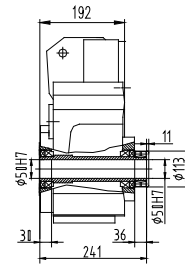

F207SI/F307SI
F207AI/F307AI

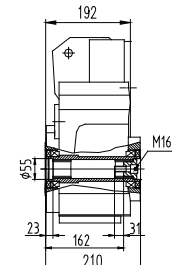

F207SK/F307SK
F207AK/F307AK

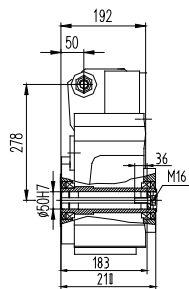

F207TG/F307TG

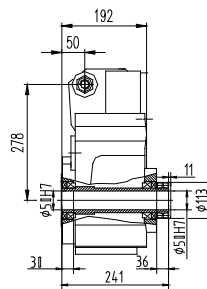

F207TI/F307TI

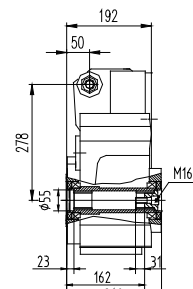

F207TK/F307TK

F208/F308

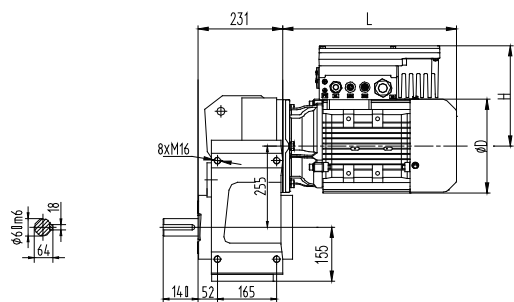

F208HA/F308HA

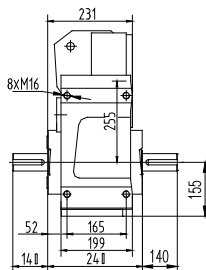

F208HC/F308HC

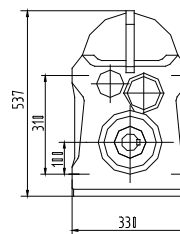

Horizontal foot-mounted H

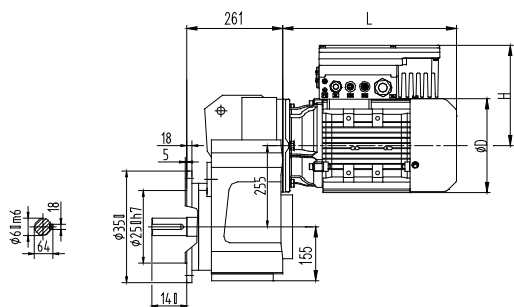

F208FA/F308FA

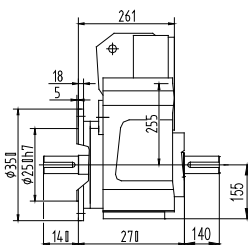

F208FC/F308FC

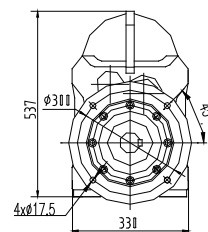

Flange-mounted F

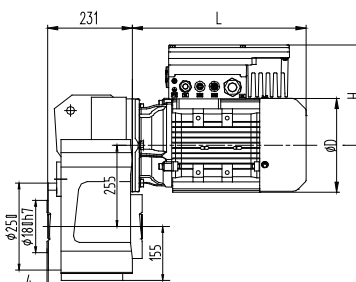
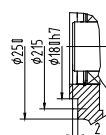

Short flange-mounted S
Shaft-mounted(A)

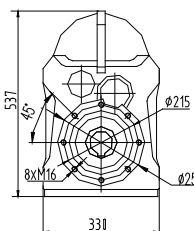

Torque arm-mounted with accessory T

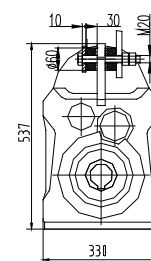
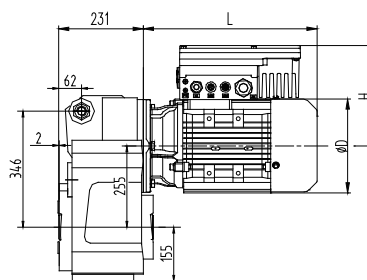

Torque arm-mounted with accessory T

Dimension Data of Gearmotor Variable Frequency Drive
All-in-one (mm) 50Hz-1500r/min

Power of 4 pole type (600)	Range of Ratio	MH			MP		
		L	D	H	L	D	H
2.2	125-200	378	198	191	378	198	191
3	90-200	378	198	191	378	198	191

F208/F308

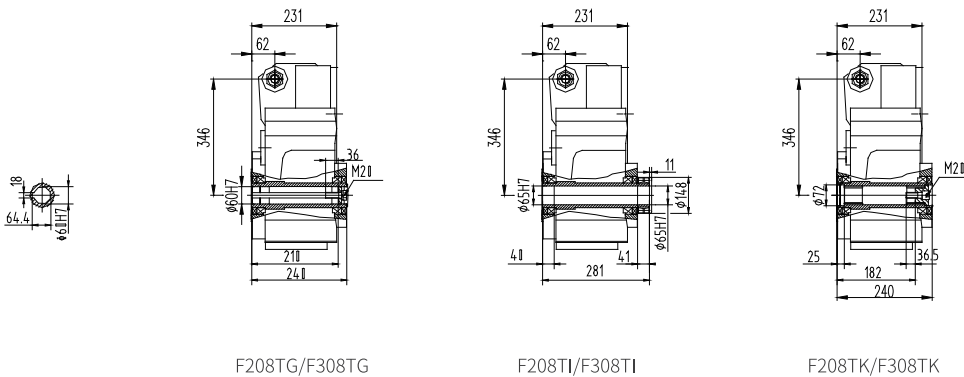
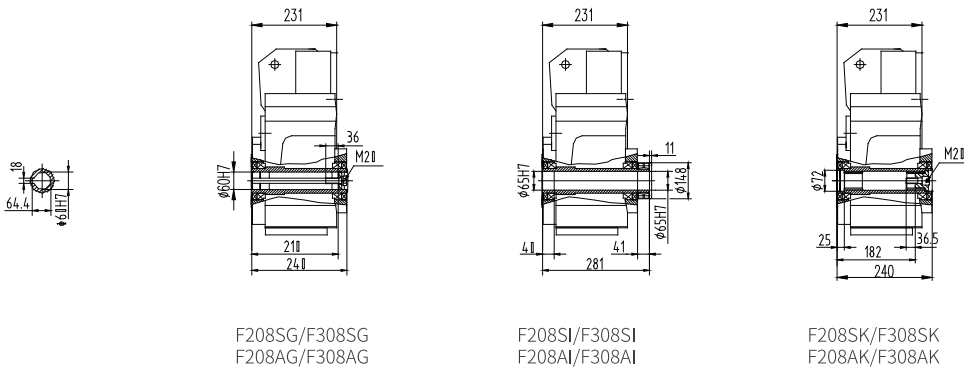
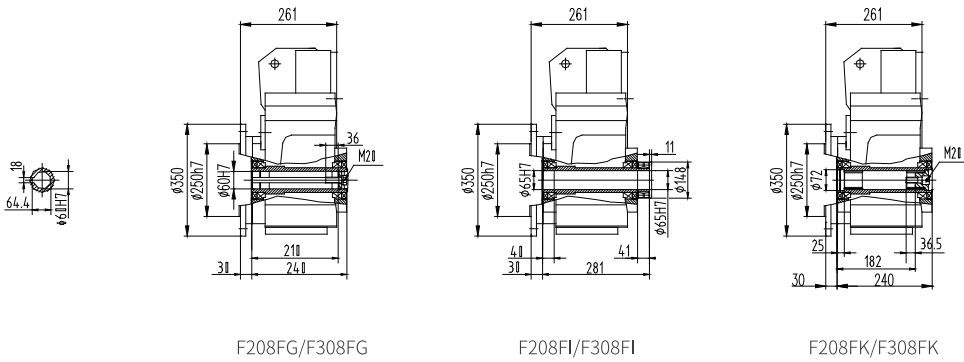
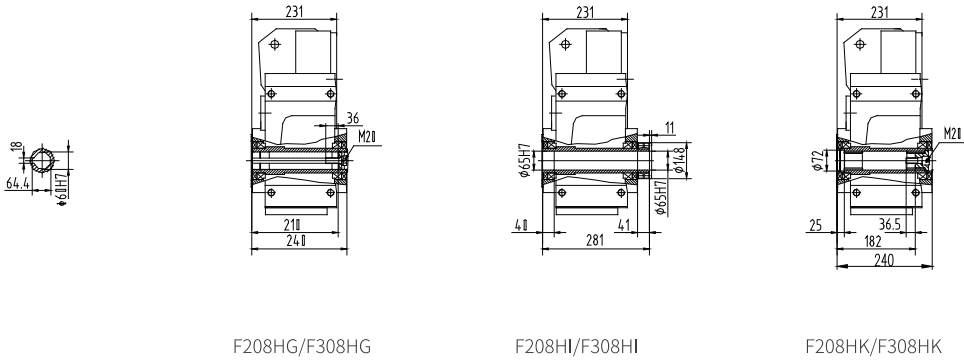

**7. 允许的输出轴径向力
Fr2(N)**

**7. Permissible Radial Force
of Output Shaft Fr2(N)**

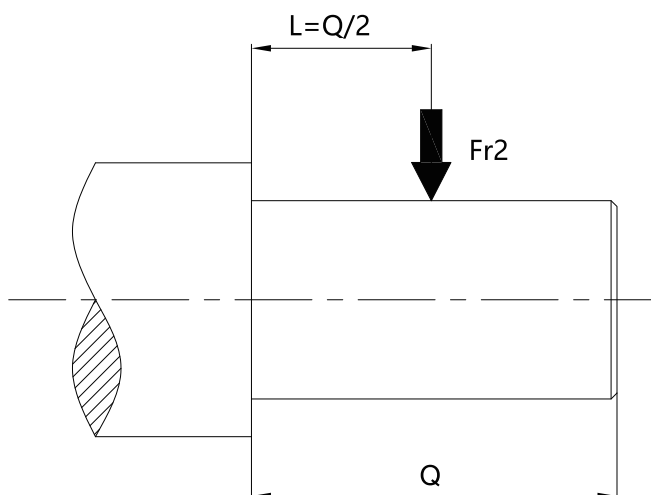

n _{2N} (r/min)	Fr ₂ (N)						
	F202 F302	F203 F303	F204 F304	F205 F305	F206 F306	F207 F307	F208 F308
315~425	1281	1827	2079	3986	7641	9140	9210
280~315	1334	1908	2115	4104	7965	9320	9480
224~280	1378	1971	2151	4220	8280	9510	9770
200~224	1423	2043	2223	4396	8694	9700	10060
180~200	1448	2115	2277	4549	9090	9890	10360
160~180	1478	2115	2646	5095	9810	10090	10670
140~160	1548	2214	2925	5478	10260	10290	11000
125~140	1623	2322	3096	5357	9270	10500	11320
112~125	1695	2475	3366	5586	9270	10710	11660
100~112	1745	2547	3555	5741	9270	10920	12010
90~100	1892	2763	3888	6003	9270	11140	12370
80~90	1961	2862	4005	6093	9270	11370	12740
71~80	2090	3051	4293	6308	9270	11600	13130
63~71	2157	3150	4527	6478	9270	11820	13520
56~63	2410	3519	4923	6755	9270	12060	13930
45~56	2503	3654	5247	6974	9270	12300	14340
40~45	2644	3861	5328	7028	9270	12550	14770
35.5~40	2644	3861	5328	7028	9270	12800	15220
31.5~35.5	2644	3861	5328	7028	9270	13050	15670
28~31.5	2644	3861	5328	7028	9270	13320	16150
25~28	2644	3861	5328	7028	9270	13580	16630
22.4~25	2644	3861	5328	7028	9270	13850	17130
≤22.4	2644	3861	5328	7028	9270	14130	17640

8.被驱动轴推荐尺寸(mm)

8.Recommended Dimensions for Driven Equipment Shaft (mm)

8.1锁紧盘

8.1 Shrink Disk

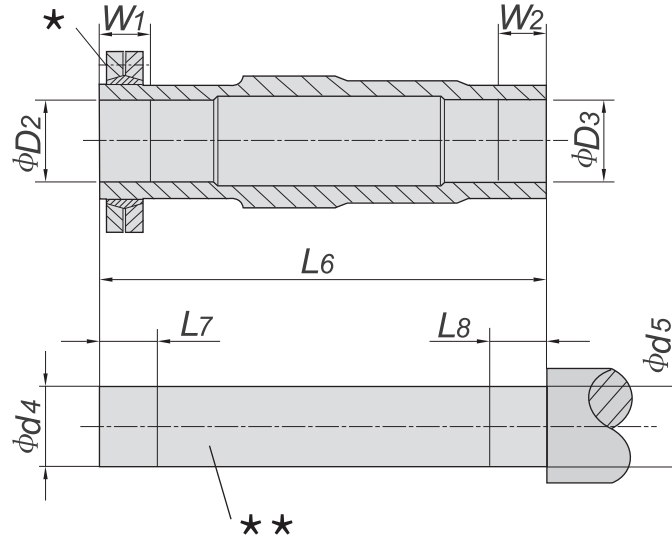

	D2	D3	d4	d5	L6	L7	L8	W1	W2	锁紧盘 型号 Shrink Disk Type	锁紧盘 螺栓 Shrink Disk Bolt	锁紧盘 重量(kg) Shrink Disk Weight (kg)
F202 F302	25H7	25H7	25h6	25h6	128	35	35	30	30	SP2-36×72	M6	0.5
F203 F303	30H7	30H7	30h6	30h6	146	35	25	30	20	SP2-44×80	M6	0.6
F204 F304	35H7	35H7	35h6	35h6	177	35	25	30	20	SP2-44×80	M6	0.6
F205 F305	40H7	40H7	40h6	40h6	195	40	30	35	25	SP2-50×90	M6	0.8
F206 F306	40H7	40H7	40h6	40h6	208	43	25	38	20	SP2-50×90	M6	0.8
F207 F307	50H7	50H7	50h6	50h6	241	41	35	36	30	SP2-62×110	M6	1.3
F208 F308	65H7	65H7	65h6	65h6	281	46	45	41	40	SP2-80×145	M8	1.9

★ 螺栓

★ Bolt

★★ 被驱动轴

★★ Driven Equipment Shaft

8.2花键轴

8.2 Involute Spline

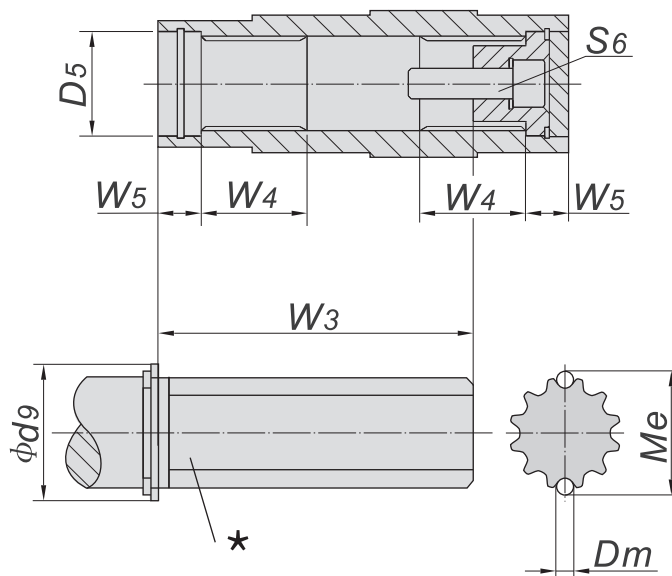

	渐开线花键参数DIN5480 模数x齿数x压力角x大径x9H Involute spline size DIN 5480 m x Z x α x D x 9H	D5	Dm	d9	Me	W3	W4	W5	S6
F202 F302	1.25x18x30x25x9H	32	2.75	36	27.99	72	25	18	M10X30
F203 F303	1.25x22x30x30x9H	37	2.75	42	33.03	85	25	18	M10X30
F204 F304	2x16x30x35x9H	37	4	42	38.92	115	32	18	M10X30
F205 F305	2x16x30x35x9H	42	4	47	38.92	125	42	25	M16X40
F206 F306	2x16x30x35x9H	42	4	47	38.92	140	42	25	M16X40
F207 F307	2x24x30x50x9H	55	4	62	54.13	160	52	23	M16X50
F208 F308	2x31x30x65x9H	72	4	82	68.96	180	62	25	M20X60

★ 被驱动轴

★ Driven Equipment Shaft

9.轴端C型螺纹中心孔

9.Type C screw central hole in shaft end

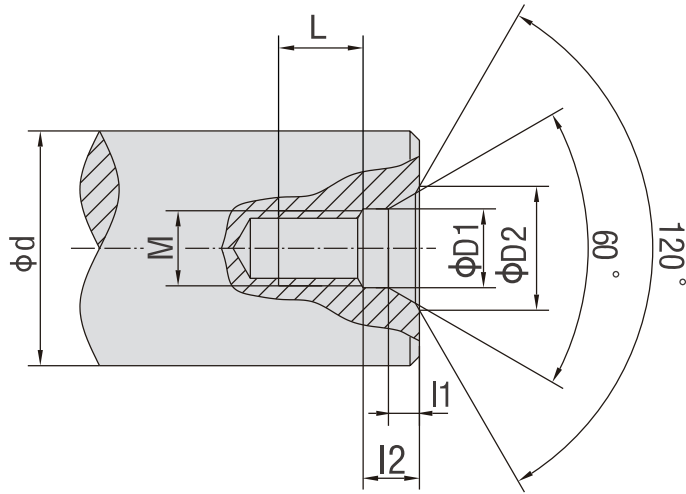

d	M	L	l2	l1	D1	D2
7 < d ≤ 10	M3	10	2.6	1.8	3.2	5.8
10 < d ≤ 13	M4	10	3.2	2.1	4.3	7.4
13 < d ≤ 16	M5	10	4	2.4	5.3	8.8
16 < d ≤ 21	M6	12	5	2.8	6.4	10.5
21 < d ≤ 24	M8	12	6	3.3	8.4	13.2
24 < d ≤ 30	M10	15	7.5	3.8	10.5	16.3
30 < d ≤ 38	M12	20	9.5	4.4	13	19.8
38 < d ≤ 50	M16	25	12	5.2	17	25.3
50 < d ≤ 85	M20	30	15	6.4	21	31.3
85 < d ≤ 130	M24	35	18	8	25	38
130 < d ≤ 225	M30	45	18	11	31	48

**10.平键与键槽的尺寸
(mm)**

**10. Dimension of Parallel
Key and Keyway(mm)**

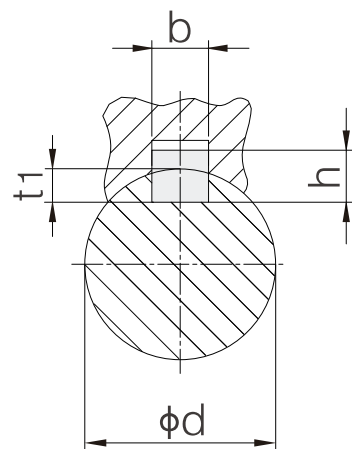
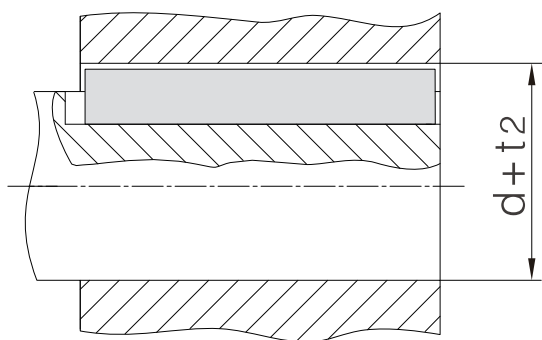

d	b	h	t ₁	d + t ₂
8 < d ≤ 10	3	3	1.8	d + 1.4
10 < d ≤ 12	4	4	2.5	d + 1.8
12 < d ≤ 17	5	5	3	d + 2.3
17 < d ≤ 22	6	6	3.5	d + 2.8
22 < d ≤ 30	8	7	4	d + 3.3
30 < d ≤ 38	10	8	5	d + 3.3
38 < d ≤ 44	12	8	5	d + 3.3
44 < d ≤ 50	14	9	5.5	d + 3.8
50 < d ≤ 58	16	10	6	d + 4.3
58 < d ≤ 65	18	11	7	d + 4.4
65 < d ≤ 75	20	12	7.5	d + 4.9
75 < d ≤ 85	22	14	9	d + 5.4
85 < d ≤ 95	25	14	9	d + 5.4
95 < d ≤ 110	28	16	10	d + 6.4
110 < d ≤ 130	32	18	11	d + 7.4
130 < d ≤ 150	36	20	12	d + 8.4
150 < d ≤ 170	40	22	13	d + 9.4
170 < d ≤ 200	45	25	15	d + 10.4
200 < d ≤ 230	50	28	17	d + 11.4
230 < d ≤ 260	56	32	20	d + 12.4

11. 可选附件和指定配置

11. Accessories and Specific Configuration

齿轮马达在以下工况时建议采用补偿油箱浸油润滑。

1. 在安装方位为D2时，出厂已配置补偿油箱；
2. 在安装方位为D4且长时间连续运转时，建议配置补偿油箱。

Oil compensating tank lubrication is recommended for gearmotor under working conditions below.

1. Oil compensating tank has been equipped for gearmotors with D2 installation position before delivery;
2. Oil compensating tank is recommended for gearmotors with D4 installation position and long duration continuous operation.

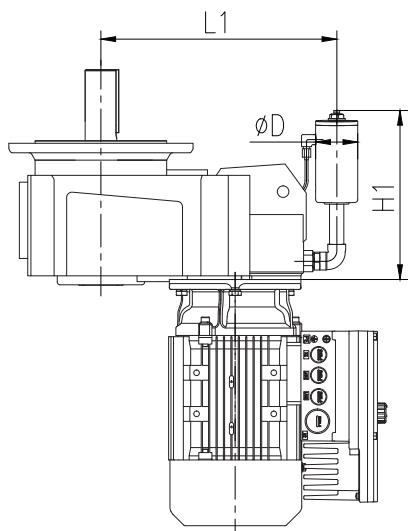

D4

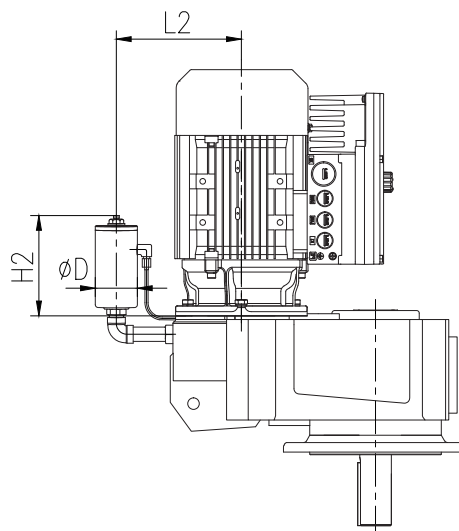

D5

	D	L1	H1	L2	H2
F202 F302	42	225	220	275	110
F203 F303	42	240	215	290	115
F204 F304	42	280	220	325	110
F205 F305	42	280	220	330	115
F206 F306	42	310	220	360	110
F207 F307	80	400	370	505	200
F208 F308	80	480	375	585	200

**12.不同安装方位的
润滑油用量 (L)**

**12.The oil quantities on dif-
ferent mounting positon (L)**

	D1	D2	D3	D4	D5	D6
F202 F302	0.7	0.9	1	1	0.9	0.8
F203 F303	1.2	1.4	1.3	1.5	1.3	1.1
F204 F304	1.8	2.1	2.2	2.3	2.2	1.9
F205 F305	2.1	2.8	2.5	2.9	2.4	2.3
F206 F306	3.1	3.9	4.1	4.2	3.9	3.3
F207 F307	5.8	7.8	7.6	8.6	7.2	6.8
F208 F308	10.9	14.8	13.7	14.7	13.2	11.3

13.重量表

13. Weight

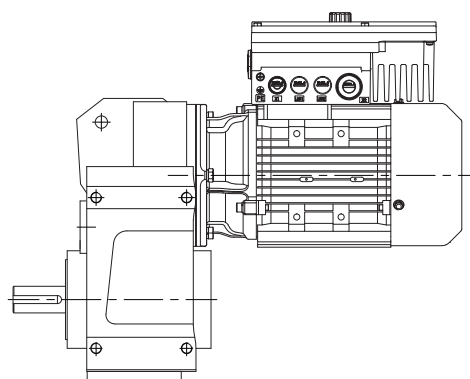

F202 F302	F203 F303	F204 F304	F205 F305	F206 F306	F207 F307	F208 F308		
12	16	20	26	36	60	107		
	071M	071M	080M	080M	090S	090M	100M	100M
	0.25	0.37	0.55	0.75	1.1	1.5	2.2	3
MH	8	9	14	15	18	19	30	33
MP	9	10	15	16	21	23	32	36

随着技术迭代进步，博能产品样本将会同步更新，请见谅。
Along with the technology advancedet.,the product of
the manual of Boneng will be changed,please forgive.

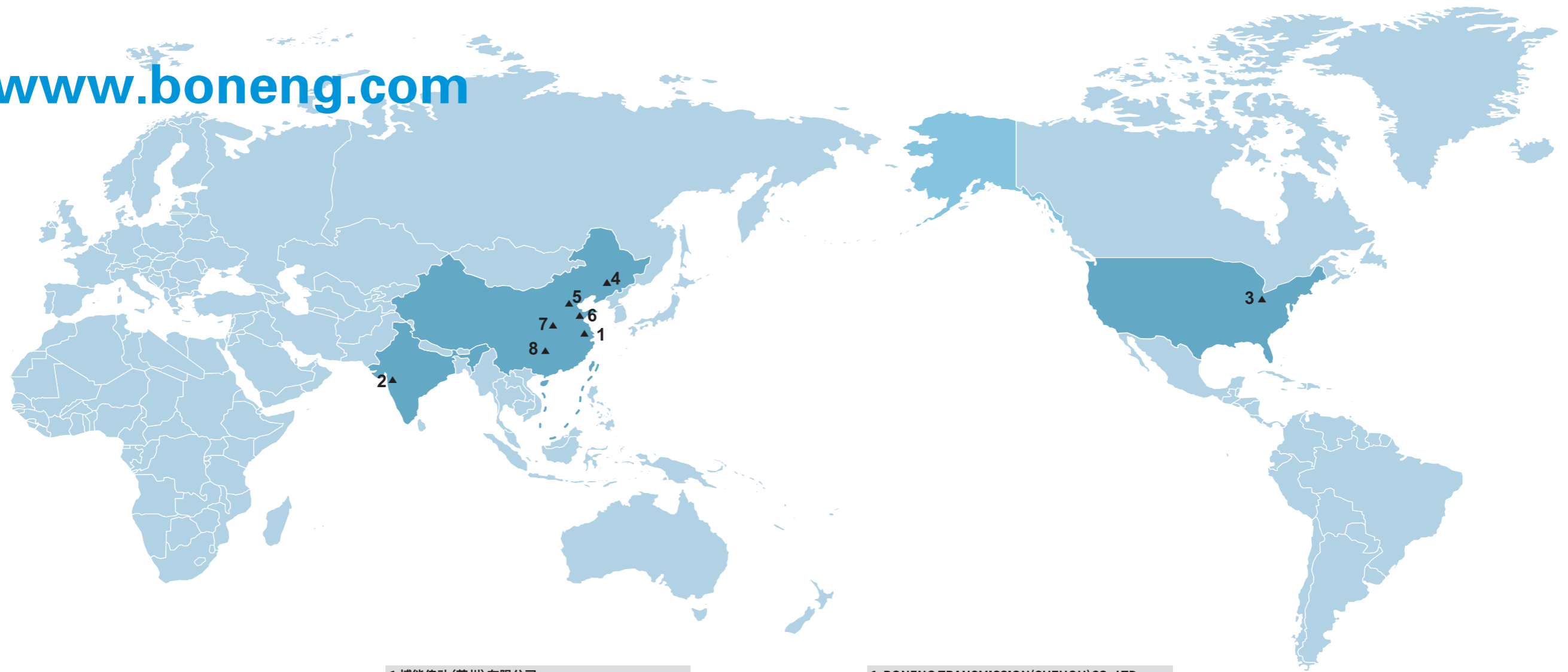

1 博能传动(苏州)有限公司
江苏省苏州市相城区如元路100号 215131
TEL: 0512-66189662

2 博能传动(印度)有限公司
Plot No. E-10/3, MIDC sinnar (Malegaon)
Industrial Area, Nashik, 422123,
Maharashtra, India.
TEL:+91-11- 4507 6293 (DELHI)
TEL:+91-22-2781 3385 (MUMBAI)

3 博能传动(美国)有限公司
1250 E 222nd Euclid, OH 44117,United Staes
TEL: 1-216-618-3099
TEL: 1-216-618-0138

4 博能传动(沈阳)有限公司
沈阳市沈北新区太平洋工业城A区A73-6号 110013
TEL: 024-31271571

5 博能传动(天津)有限公司
天津市北辰区双海道6号宏鹏工业园7号车间 300021
TEL: 022-26929556

6 博能传动(潍坊)有限公司
山东省潍坊市安丘市经济开发区汶水路与
昆仑大街交叉口往北100米路东1号车间 261000
TEL: 0536-2141166

7 博能传动(开封)有限公司
河南省开封市宋城路四大街11号海神机械院内五号厂房 475000
TEL: 0371-23335238

8 博能传动(长沙)有限公司
长沙市望城经济开发区普瑞大道1288号 410205
TEL: 0731-88386958

1 BONENG TRANSMISSION(SUZHOU)CO.,LTD.
No. 100, Ruyuan Road, Xiangcheng District, 215131
Suzhou, Jiangsu Province, China
TEL: 0512-66189662

2 BONENG TRANSMISSION(INDIA)PVT.LTD
Plot No. E-10/3, MIDC sinnar (Malegaon)
Industrial Area, Nashik, 422123,
Maharashtra, India.
TEL:+91-11- 4507 6293 (DELHI)
TEL:+91-22-2781 3385 (MUMBAI)

3 BONENG TRANSMISSION(USA)LLC.
1250 E 222nd Euclid, OH 44117,United Staes
TEL: 1-216-618-3099
TEL: 1-216-618-0138

4 BONENG TRANSMISSION(SHENYNG)CO.,LTD.
No. A73-6, Area A, Pacific Industrial City, Shenbei 110013
New District, Shenyang, Liaoning Province, China
TEL: 024-31271571

5 BONENG TRANSMISSION(TIANJIN)CO.,LTD.
7th Workshop, Hongpeng Industrial Park, No.6
Shuanghai Road, Beichen District, Tianjin City,China 300021
TEL: 022-26929556

6 BONENG TRANSMISSION(WEIFANG)CO.,LTD.
1st Workshop, Economic Development Zone, Anqiu, 261000
Weifang City, Shandong Province, China
TEL: 0536-2141166

7 BONENG TRANSMISSION(KAIFENG)CO.,LTD.
5th Workshop, Haishen Machinery, No.11, Fourth
Street, Songcheng Road,New District, Kaifeng City,
Henan Province, China 475000
TEL: 0371-23335238

8 BONENG TRANSMISSION(CHANGSHA)CO.,LTD.
No. 1288 Puri Avenue, Wangcheng Economic Development
Zone, Changsha City, Hunan Province, China 410205
TEL: 0731-88386958

BONENG

BONENG