

**BONENG**

ME永磁同步伺服马达&AN伺服驱动器

ME Permanent Magnet Synchronous Servo Motor & AN Servo Drives



ME永磁同步伺服马  
达&AN伺服驱动器

ME Permanent Magnet  
Synchronous Servo  
Motor & AN Servo Drives

(0.1kW~1.2kW)

Edit date 06/2026  
Selection Catalogue: C05.0056

**BONENG**

**Boneng Transmission**

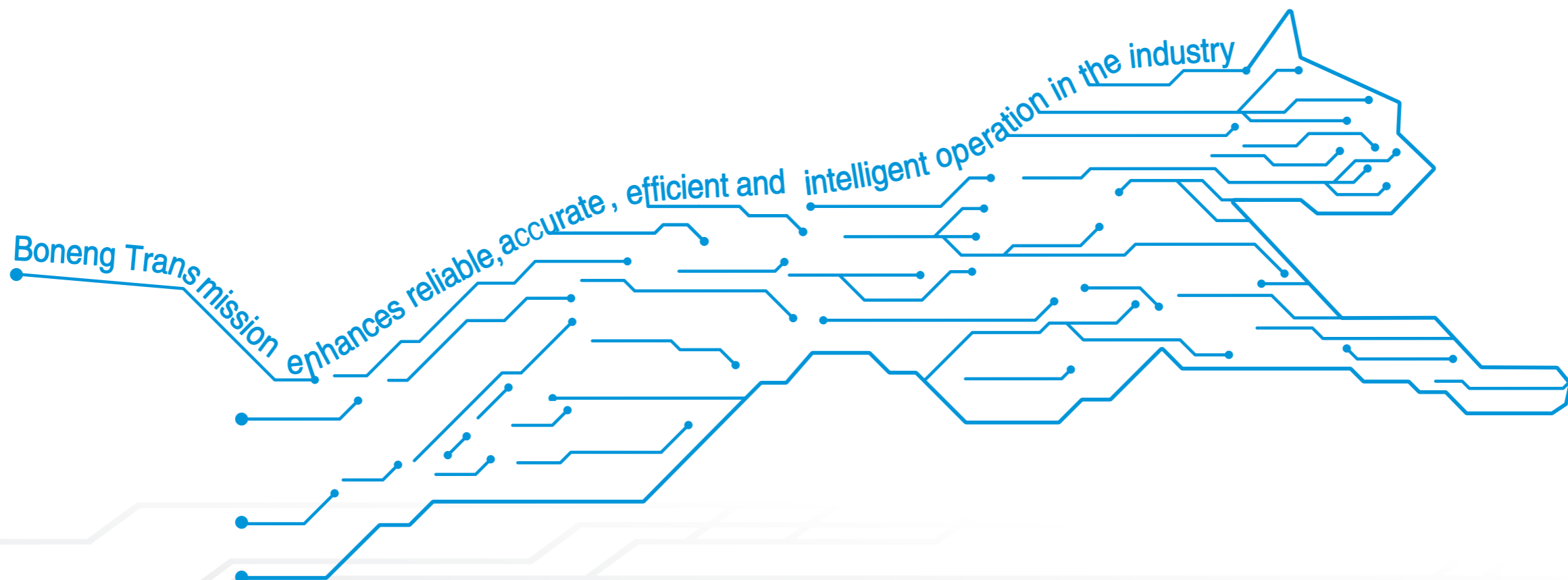

控制器/驱动器/马达/  
齿轮马达/齿轮箱

Controller/ Drive/ Motor/  
Gearmotor/ Gearbox

# 目 录

# Contents

## 伺服马达

01. 伺服马达概述 .....	01
02. 马达优点 .....	01
03. 马达应用 .....	01
04. 马达技术特征 .....	02
05. 马达运行环境 .....	02
06. 马达铭牌信息 .....	03
07. 马达制动器参数 .....	03
08. 马达型号表示方法 .....	04
09. 马达和驱动器的选型和订 货号 .....	05
10. 马达特性及外形尺寸 .....	07

## 经济型AN系列伺服驱动器

11. 伺服驱动器概述 .....	11
12. 整机外形及安装尺寸图 .....	18
13. 可选件 .....	18

## Servo Motor

01.Servo motor overview .....	01
02.Motor advantages .....	01
03.Motor application .....	01
04.Motor technical characteristics .....	02
05.Motor operating environment .....	02
06.Motor nameplate information .....	03
07.Motor brake parameters .....	03
08.Motor model indication method .....	04
09.Selection and order numbers of motor and drives .....	05
10.Motor characteristics and dimensions .....	07

## Economic AN series servo drive

11.Overview of servo drives .....	11
12.Overall appearance and installation dimension diagram .....	18
13.Optional Items .....	18

## 伺服马达

### 1 伺服马达概述

ME系列伺服马达匹配博能AN系列220V伺服驱动器可组成精确定位的伺服系统。

ME伺服马达出厂常用的冷却方式为自然冷却,适用于连续工作制(S1),同时也满足大部分断续工作方式(S2-S10)。

ME伺服马达设计生产符合ISO、IEC、GB等相关标准要求。

### 2 马达优点

- ◆ 法兰机壳一体, 结构强度高
- ◆ IP66防护等级, 防尘防水
- ◆ 轻量化设计, 尺寸短小
- ◆ 优化散热工艺, 温升低
- ◆ 高性能, 可达三倍过载转矩

### 3 马达应用

- ◆ 包装机械
- ◆ 半导体行业
- ◆ 电子制造行业
- ◆ 锂电行业
- ◆ 贴片机行业
- ◆ 仓储物流

## Servo Motor

### 1 Servo motor overview

ME series servo motor and AN series 220V servo drive can compose a precise positioning servo system.

The commonly used cooling method of the ME series servo motor is natural cooling, making them suitable for continuous duty (S1), while also meeting most intermittent duty modes (S2-S10). The design and production of ME servo motors comply with relevant standards, such as ISO, IEC, GB, and others.

### 2 Motor advantages

- ◆ Integrated flange casing, high structural strength
- ◆ IP66 degree of protection, dustproof and waterproof
- ◆ Lightweight design and small size
- ◆ Optimized heat dissipation process, low temperature rise
- ◆ High performance, up to three times the overload torque

### 3 Motor application

- ◆ Packaging machinery
- ◆ Semiconductor industry
- ◆ Electronic manufacturing industry
- ◆ Lithium electricity industry
- ◆ Placement machine industry
- ◆ Warehousing logistics

## 4 马达技术特征

马达型号	Motor model	永磁同步伺服马达	Permanent magnet synchronous servo motor
磁性材料	Magnetic material	稀土永磁材料	Rare earth permanent magnet material
轴高(mm)	Shaft height(mm)	20、30、40	20、30、40
额定功率(kW)	Rated power(kW)	0.1-1.2	0.1-1.2
额定转矩(N.m)	Rated torque(N.m)	0.32-3.82	0.32-3.82
额定转速(r/min)	Rated speed(r/min)	3000	3000
绝缘等级	Insulation class	F	F
防护等级	Protection class	IP66	IP66
冷却方式	Cooling method	自然冷却	Natural cooling
振动等级	Vibration level	A级	Class A
噪声(dB)	Noise(dB)	55-70	55-70
径向圆跳精度、同轴度和断面圆跳精度等级	Runout Accuracy and Concentricity	N	N
安装形式	Installation form	IMB5	IMB5
驱动轴伸	Drive shaft extension	平键轴	Flat key shaft
编码器分辨率	Encoder resolution	17bit	17bit
连接器	Connector	动力和信号连接器	Power and signal connectors
选件	Options	内置电磁失电制动器	Built-in permanent magnet power-off brake

## 4 Motor technical characteristics

## 5 马达运行环境

所允许的相对湿度:  
 $-15^{\circ}\text{C} \leq T \leq 20^{\circ}\text{C}: 100\%$   
 $20^{\circ}\text{C} < T \leq 30^{\circ}\text{C}: 95\%$   
 $30^{\circ}\text{C} < T \leq 40^{\circ}\text{C}: 55\%$

对于更高的环境温度、以及(或者)高于海拔1000m的地点, 马达的额定功率换算系数为 $K_{ht}$ 所允许的功率值:  $P_n' = P_n \cdot K_{ht}$

## 5 Motor operating environment

Allowable relative humidity:  
 $-15^{\circ}\text{C} \leq T \leq 20^{\circ}\text{C}: 100\%$   
 $20^{\circ}\text{C} < T \leq 30^{\circ}\text{C}: 95\%$   
 $30^{\circ}\text{C} < T \leq 40^{\circ}\text{C}: 55\%$

For higher ambient temperatures, and above 1000m altitude, the motor's rated power conversion factor is the power value allowed by  $K_{ht}$ :  $P_n' = P_n \cdot K_{ht}$

对于不同高度和(或)不同环境温度的功率折算系数 $K_{ht}$		Power conversion factor for different altitudes and different ambient temperatures $K_{ht}$				
海拔高度 Altitude	对应海拔高度的环境温度 Ambient temperature corresponding to altitude					
	<30°C	30~40°C	45°C	50°C	55°C	60°C
1000 m	1.07	1	0.96	0.92	0.87	0.82
1500 m	1.04	0.97	0.93	0.89	0.84	0.79
2000 m	1	0.94	0.9	0.86	0.82	0.77
2500 m	0.96	0.9	0.86	0.83	0.78	0.74
3000 m	0.92	0.86	0.82	0.79	0.75	0.7
3500 m	0.88	0.82	0.79	0.75	0.71	0.67
4000 m	0.82	0.77	0.74	0.71	0.67	0.63

6 马达铭牌信息

6 Motor nameplate information

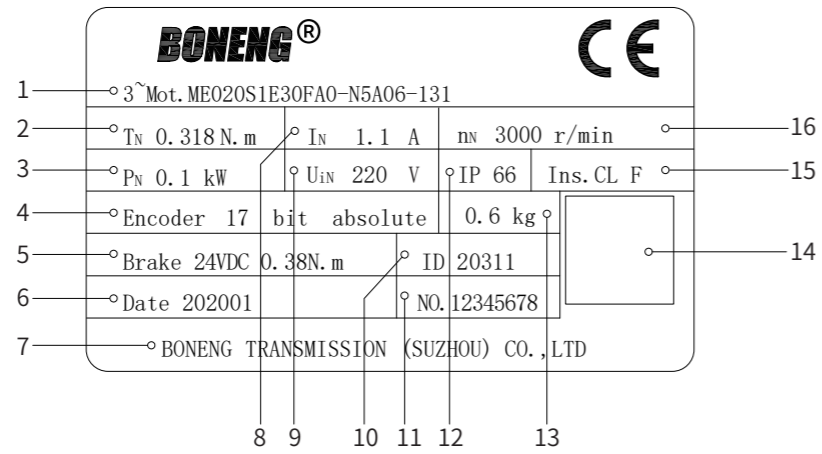

- |          |          |                         |                      |
|----------|----------|-------------------------|----------------------|
| 1. 马达型号  | 9. 额定电压  | 1. Model of motor       | 9. Rated voltage     |
| 2. 额定转矩  | 10. 马达ID | 2. Rated torque         | 10. ID of the motor  |
| 3. 额定功率  | 11. 出厂编号 | 3. Rated power          | 11. Factory number   |
| 4. 编码器参数 | 12. 防护等级 | 4. Parameter of encoder | 12. Protection class |
| 5. 制动器参数 | 13. 重量   | 5. Parameter of brake   | 13. Weight           |
| 6. 生产日期  | 14. 二维码  | 6. Date in produced     | 14. QR code          |
| 7. 公司名称  | 15. 绝缘等级 | 7. Company name         | 15. Insulation class |
| 8. 额定电流  | 16. 额定转速 | 8. Rated current        | 16. Rated speed      |

7 马达制动器参数

7 Motor brake parameters

制动器型号	Brake model	BN020	BN030	BN040	BN050
静摩擦力矩 (N.m)	Static friction torque (N.m)	≥0.38	≥1.52	≥3.8	≥8
制动器功率 (W)	Brake power (W)	6.1	7.3	8.5	17.6
线圈电阻 (Ω)	Coil resistance (Ω)	94.4	78.9	67.8	32.73
工作电压 (VDC)	Operating voltage (VDC)	24±10%	24±10%	24±10%	24±10%
工作温度 (°C)	Operating temperature (°C)	-15~100	-15~100	-15~100	-15~100
制动器吸合时间 (ms)	Brake pull-in time (ms)	≤50	≤60	≤60	≤100
制动器释放时间 (ms)	Brake release time (ms)	≤20	≤40	≤40	≤40
径向负载 (N.m)	Radial load (N.m)	68	246	392	583
轴向负载 (N.m)	Axial load (N.m)	58	98	147	214
适配马达机座号	Compatible motor frame size	20	30	40	50

8 马达型号表示方法

8 Motor model indication method

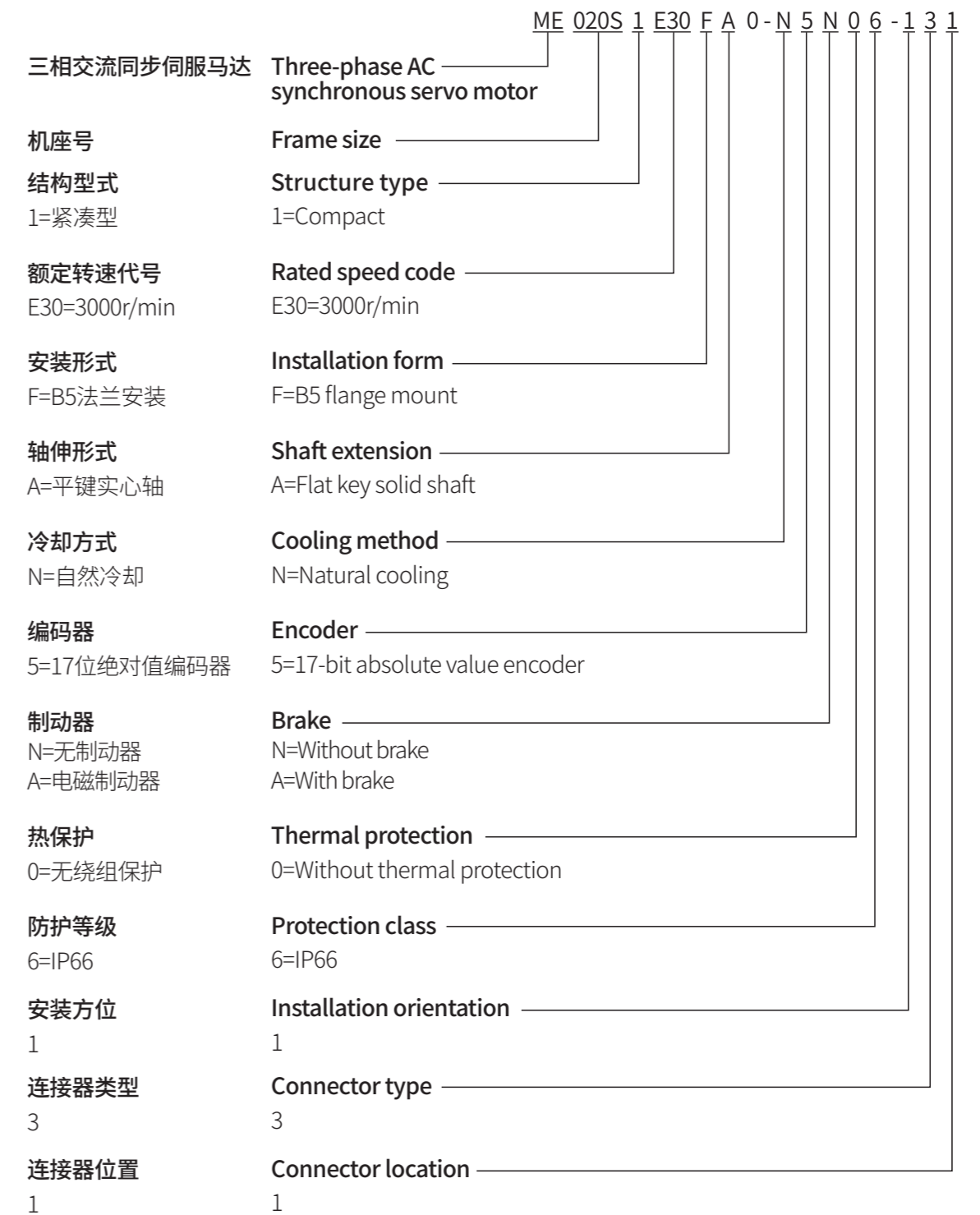

9 马达和驱动器的选型和  
订货号

9 Selection and order  
numbers of motor and drives

马达 机座号	马达 额定功率 (kW)	马达 额定转速 (r/min)	马达容许 最大惯量比	马达		马达订货号	驱动器订货号	
				Motor				
Motor frame size	Motor rated power (kW)	Motor rated speed (r/min)	Motor allowable maximum inertia ratio	无制动器 Without brake	带制动器 With brake	Motor order number	Servo drive order number	
020S	0.1	3000	35	32010	42010	ME020S1E30FA0-N5□06-131	AN-A3A75-S-□□	
030S	0.2	3000	15	32110	42110	ME030S1E30FA0-N5□06-131	AN-A3A75-S-□□	
030M	0.4	3000	15	32111	42111	ME030M1E30FA0-N5□06-131	AN-A3A75-S-□□	
030L	0.6	3000	10	32112	42112	ME030L1E30FA0-N5□06-131	AN-A3A75-S-□□	
040S	0.75	3000	10	32210	42210	ME040S1E30FA0-N5□06-131	AN-A3A75-S-□□	
040M	1	3000	10	32211	42211	ME040M1E30FA0-N5□06-131	AN-A3A75-S-□□	
040L	1.2	3000	10	32212	42212	ME040L1E30FA0-N5□06-131	AN-A3A75-S-□□	
050S	1.5	下单另行咨询; Place an order for additional consultation						
050M	2							
050L	2.5							

无制动器 N EtherCAT EC  
 电磁制动器 A PROFINET PN  
 Without brake N  
 With brake A

驱动器可选件: 24V辅助电源订货号	动力线订货号	信号线订货号	驱动器可选件: 制动电阻订货号
Driver options: 24V auxiliary power supply order number	Power cable order number	Signal cable order number	Drive optional part: brake resistor order number
AN-DC30024V-2A	A3-G□□-A10-□□□	A3-H17-A□□-□□□	A1-H02-A40-K-C75
AN-DC30024V-2A	A3-H□□-A10-□□□	A3-H17-A□□-□□□	A1-H02-A40-K-C75
AN-DC30024V-2A	A3-H□□-A10-□□□	A3-H17-A□□-□□□	A1-H02-A40-K-C75
AN-DC30024V-2A	A3-H□□-A10-□□□	A3-H17-A□□-□□□	A1-H02-A40-K-C75
AN-DC30024V-2A	A3-H□□-A10-□□□	A3-H17-A□□-□□□	A1-H02-A40-K-C75
AN-DC30024V-2A	A3-H□□-A10-□□□	A3-H17-A□□-□□□	A1-H02-A40-K-C75
AN-DC30024V-2A	A3-H□□-A10-□□□	A3-H17-A□□-□□□	A1-H02-A40-K-C75

无制动器 18 B30长度 3m 不带电池盒 10 B30长度 3m  
 带制动器 16 B50长度 5m 带电池盒 11 B50长度 5m  
 Without brake 18 B70长度 7m Without battery 10 B70长度 7m  
 With brake 16 C10长度 10m With battery 11 C10长度 10m  
 C15长度 15m C15长度 15m  
 C20长度 20m C20长度 20m  
 B30Length 3m B30 Length 3m  
 B50Length 5m B50 Length 5m  
 B70Length 7m B70 Length 7m  
 C10Length 10m C10 Length 10m  
 C15Length 15m C15 Length 15m  
 C20Length 20m C20 Length 20m

### 10 马达特性及外形尺寸

#### 10.1 机座号020伺服马达参数、外形尺寸以及特性曲线

马达型号	Motor model	ME020S1E30FA0-N5□06-131
额定转速 $n_N$ (r/min)	Rated speed $n_N$ (r/min)	3000
额定功率 $P_N$ (kW)	Rated power $P_N$ (kW)	0.1
额定电流 $I_N$ (A)	Rated current $I_N$ (A)	1.1
额定转矩 $T_N$ (N.m)	Rated torque $T_N$ (N.m)	0.318
最大转速 $n_{max\ inv}$ (r/min)	Maximum speed $n_{max\ inv}$ (r/min)	6000
最大电流 $I_{max\ inv}$ (A)	Maximum current $I_{max\ inv}$ (A)	3.5
最大转矩 $T_{max\ inv}$ (N.m)	Maximum torque $T_{max\ inv}$ (N.m)	0.954
转动惯量 $J$ ( $10^{-4}$ kg.m <sup>2</sup> )	Moment of inertia $J$ ( $10^{-4}$ kg.m <sup>2</sup> )	0.066(0.07)
重量 $m$ (kg)	Weight $m$ (kg)	0.4(0.6)
整机长度 $L$ (mm)	Overall length $L$ (mm)	78.8(112)

注：括号内为带抱闸的数据

### 10 Motor characteristics and dimensions

#### 10.1 Frame size 020 servo motor parameters, dimensions and characteristic curve

Note: The data in parentheses are with brake

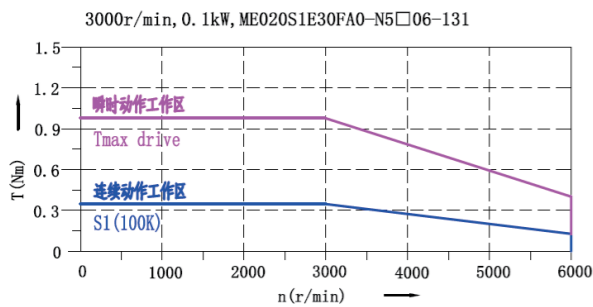
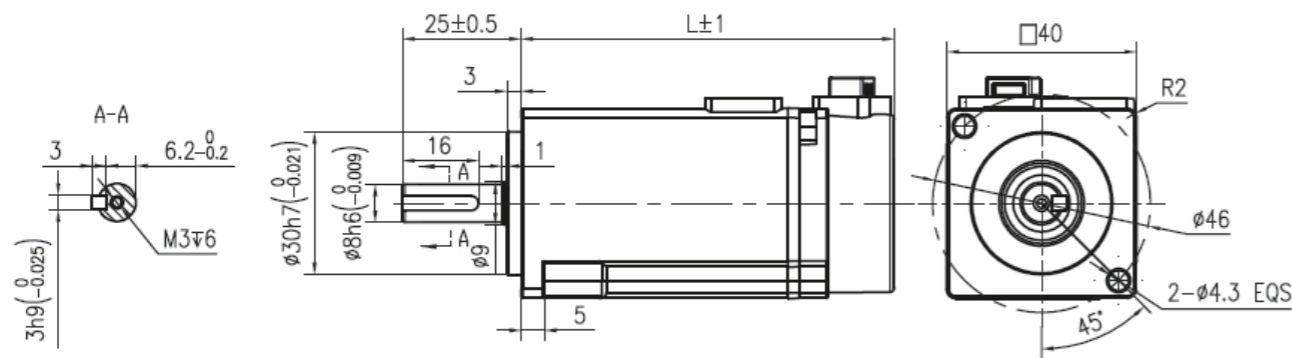

动力及抱闸电源线 Power and brake power cables	
插座编号 Socket No.	1 2 3 4 A B
绕组定义 Winding definition	U V W PE BRK+ BRK-
编码器反馈线 Encoder feedback cable	
插座编号 Socket No.	1 2 3 4 5 6 7
信号定义 Signal definition	5V 0V SD+ SD- PE E+ E-

#### 10.2 机座号030伺服马达参数、外形尺寸及特性曲线

马达型号	Motor model	ME030S1E30FA0-N5□06-131	ME030M1E30FA0-N5□06-131	ME030L1E30FA0-N5□06-131
额定转速 $n_N$ (r/min)	Rated speed $n_N$ (r/min)	3000	3000	3000
额定功率 $P_N$ (kW)	Rated power $P_N$ (kW)	0.2	0.4	0.6
额定电流 $I_N$ (A)	Rated current $I_N$ (A)	1.7	2.5	3.6
额定转矩 $T_N$ (N.m)	Rated torque $T_N$ (N.m)	0.64	1.27	1.91
最大转速 $n_{max\ inv}$ (r/min)	Maximum speed $n_{max\ inv}$ (r/min)	6000	6000	6000
最大电流 $I_{max\ inv}$ (A)	Maximum current $I_{max\ inv}$ (A)	5.7	8.4	11.2
最大转矩 $T_{max\ inv}$ (N.m)	Maximum torque $T_{max\ inv}$ (N.m)	1.92	3.81	5.73
转动惯量 $J$ ( $10^{-4}$ kg.m <sup>2</sup> )	Moment of inertia $J$ ( $10^{-4}$ kg.m <sup>2</sup> )	0.28(0.38)	0.52(0.62)	0.76(0.86)
重量 $m$ (kg)	Weight $m$ (kg)	0.8(1.1)	1.1(1.4)	1.4(1.7)
整机长度 $L$ (mm)	Overall length $L$ (mm)	73(102.5)	90(119.5)	107(136.5)

注：括号内为带抱闸的数据

#### 10.2 Frame size 030 servo motor parameters, dimensions and characteristic curve

Note: The data in parentheses are with brake

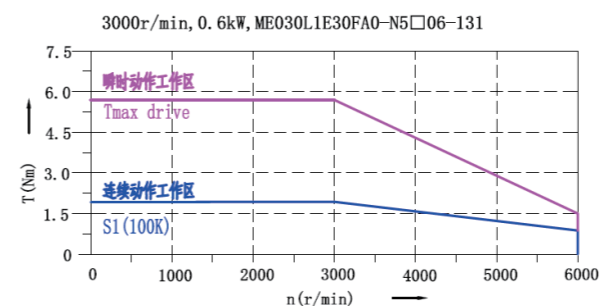
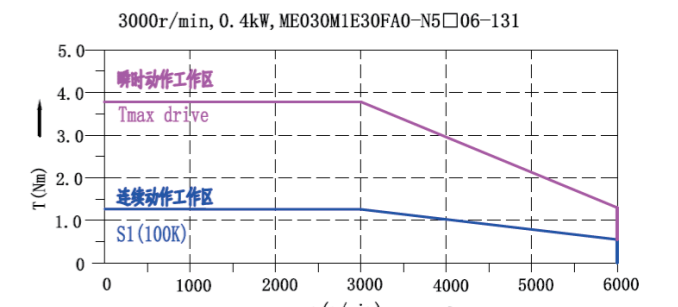
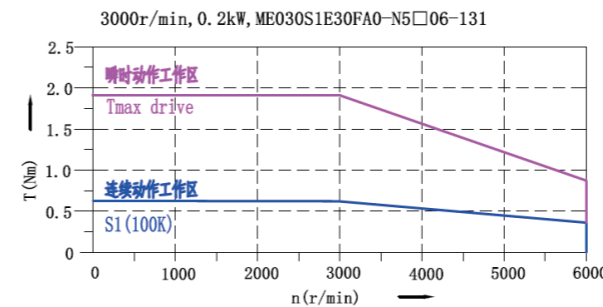
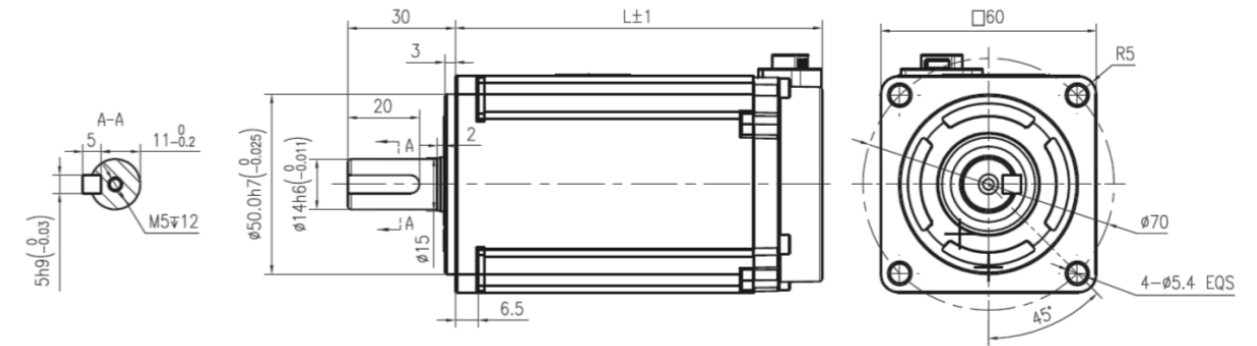

动力及抱闸电源线 Power and brake power cables	
插座编号 Socket No.	1 2 3 4 A B
绕组定义 Winding definition	U V W PE BRK+ BRK-
编码器反馈线 Encoder feedback cable	
插座编号 Socket No.	1 2 3 4 5 6 7
信号定义 Signal definition	5V 0V SD+ SD- PE E+ E-

10.3 机座号040伺服马达参数、外形尺寸及特性曲线

10.3 Frame size 040 servo motor parameters, dimensions and characteristic curve

马达型号	Motor model	ME040S1E30FA0 -N5□06-131	ME040M1E30FA0 -N5□06-131	ME040L1E30FA0 -N5□06-131
额定转速 $n_N$ (r/min)	Rated speed $n_N$ (r/min)	3000	3000	3000
额定功率 $P_N$ (kW)	Rated power $P_N$ (kW)	0.75	1	1.2
额定电流 $I_N$ (A)	Rated current $I_N$ (A)	4.4	5.8	5.7
额定转矩 $T_N$ (N.m)	Rated torque $T_N$ (N.m)	2.39	3.18	3.82
最大转速 $n_{max\ inv}$ (r/min)	Maximum speed $n_{max\ inv}$ (r/min)	6000	6000	4000
最大电流 $I_{max\ inv}$ (A)	Maximum current $I_{max\ inv}$ (A)	13.8	18.1	17.1
最大转矩 $T_{max\ inv}$ (N.m)	Maximum torque $T_{max\ inv}$ (N.m)	7.17	9.54	11.46
转动惯量 $J$ ( $10^{-4}$ kg.m <sup>2</sup> )	Moment of inertia $J$ ( $10^{-4}$ kg.m <sup>2</sup> )	1.48 (1.78)	2.27 (2.5)	2.6 (2.78)
重量 $m$ (kg)	Weight $m$ (kg)	2.1 (2.8)	2.5 (3.2)	3.1 (3.8)
整机长度 $L$ (mm)	Overall length $L$ (mm)	96.5 (130.5)	109.5 (143.5)	128.5 (162.5)

注：括号内为带抱闸的数据

Note: The data in parentheses are with brake

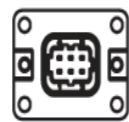
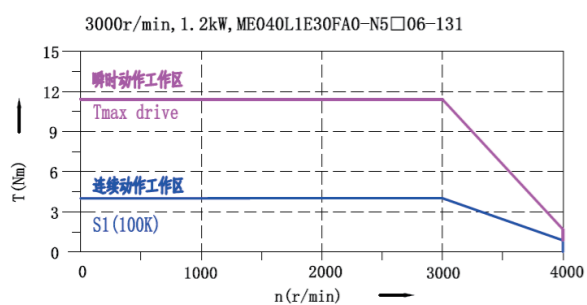
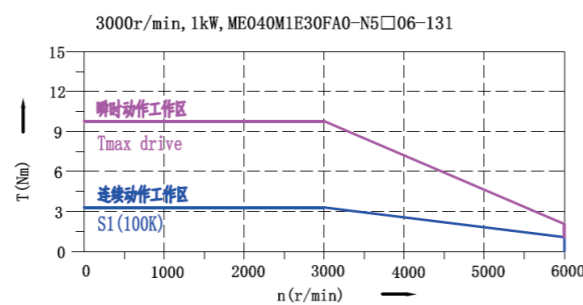
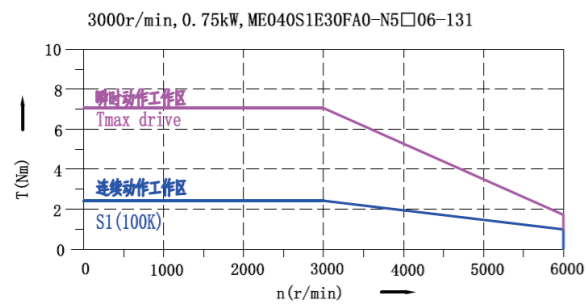
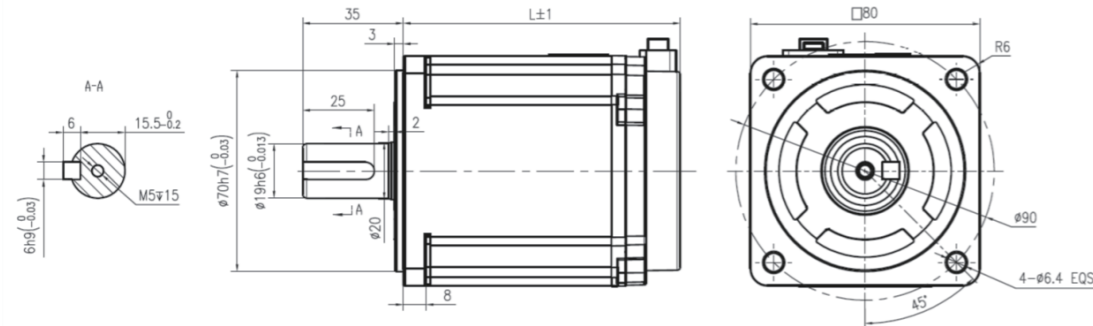

动力及抱闸电源线 Power and brake power cables						
插座编号 Socket No.	1	2	3	4	A	B
绕组定义 Winding definition	U	V	W	PE	BRK+	BRK-

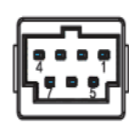

编码器反馈线 Encoder feedback cable							
插座编号 Socket No.	1	2	3	4	5	6	7
信号定义 Signal definition	5V	0V	SD+	SD-	PE	E+	E-

10.4 机座号055伺服马达参数、外形尺寸及特性曲线

10.4 Frame size 055 servo motor parameters, dimensions and characteristic curve

马达型号	Motor model	ME055S1E30FA0 -N5□06-111	ME055M1E30FA0 -N5□06-111	ME055L1E30FA0 -N5□06-111
额定转速 $n_N$ (r/min)	Rated speed $n_N$ (r/min)	3000	3000	3000
额定功率 $P_N$ (kW)	Rated power $P_N$ (kW)	1.5	2	2.6
额定电流 $I_N$ (100K) (A)	Rated current $I_N$ (100K) (A)	7	9.5	9.5
额定转矩 $T_N$ (100K) (N.m)	Rated torque $T_N$ (100K) (N.m)	4.8	6.4	8.3
最大转速 $n_{max\ inv}$ (r/min)	Maximum speed $n_{max\ inv}$ (r/min)	5000	5000	3500
最大电流 $I_{max\ inv}$ (A)	Maximum current $I_{max\ inv}$ (A)	21	28.5	28.5
最大转矩 $T_{max\ inv}$ (N.m)	Maximum torque $T_{max\ inv}$ (N.m)	14.4	19.2	24.9
转动惯量 $J$ ( $10^{-4}$ kg.m <sup>2</sup> )	Moment of inertia $J$ ( $10^{-4}$ kg.m <sup>2</sup> )	6.6 (7.2)	9.5 (10.1)	10.4 (11)
重量 $m$ (kg)	Weight $m$ (kg)	5.5 (6.5)	7.7 (8.8)	8.2 (9.4)
整机长度 $L$ (mm)	Overall length $L$ (mm)	154.5 (195.5)	167.5 (208.5)	167.5 (208.5)

注：括号内为带抱闸的数据

Note: The data in parentheses are with brake

10.5 机座号065伺服马达参数、外形尺寸及特性曲线

10.5 Frame size 065 servo motor parameters, dimensions and characteristic curve

马达型号	Motor model	ME065S1E20FA0 -N5□06-111	ME065M1E15FA0 -N5□06-111	ME065L1E15FA0 -N5□06-111	ME065H1E15FA0 -N5□06-111
额定转速 $n_N$ (r/min)	Rated speed $n_N$ (r/min)	2000	1500	1500	1500
额定功率 $P_N$ (kW)	Rated power $P_N$ (kW)	1.1	1.3	1.8	2.3
额定电流 $I_N$ (100K) (A)	Rated current $I_N$ (100K) (A)	6	7.7	9.8	12.4
额定转矩 $T_N$ (100K) (N.m)	Rated torque $T_N$ (100K) (N.m)	5.25	8.28	11.46	14.64
最大转速 $n_{max\ inv}$ (r/min)	Maximum speed $n_{max\ inv}$ (r/min)	4000	3000	3000	3000
最大电流 $I_{max\ inv}$ (A)	Maximum current $I_{max\ inv}$ (A)	18.5	23.7	30.2	38.4
最大转矩 $T_{max\ inv}$ (N.m)	Maximum torque $T_{max\ inv}$ (N.m)	15.75	24.84	34.38	43.92
转动惯量 $J$ ( $10^{-4}$ kg.m <sup>2</sup> )	Moment of inertia $J$ ( $10^{-4}$ kg.m <sup>2</sup> )	12.1 (14.1)	17.5 (19.5)	23.7 (25.7)	31.2 (33.2)
重量 $m$ (kg)	Weight $m$ (kg)	5.2 (6.7)	6.6 (7.8)	8 (9.5)	10 (11.5)
整机长度 $L$ (mm)	Overall length $L$ (mm)	130 (155.5)	146 (171.5)	164 (189.5)	186 (211.5)

注：括号内为带抱闸的数据

Note: The data in parentheses are with brake

10.6 机座号090伺服马达参数、外形尺寸及特性曲线

10.6 Frame size 090 servo motor parameters, dimensions and characteristic curve

马达型号	Motor model	ME090S1E15FA0 -N5□06-111	ME090M1E15FA0 -N5□06-111	ME090L1E15FA0 -N5□06-111	ME090H1E15FA0 -N5□06-111
额定转速 $n_N$ (r/min)	Rated speed $n_N$ (r/min)	1500	1500	1500	1500
额定功率 $P_N$ (kW)	Rated power $P_N$ (kW)	3	4.5	5.5	7.5
额定电流 $I_N$ (100K)(A)	Rated current $I_N$ (100K)(A)	11	15.9	20.2	25.8
额定转矩 $T_N$ (100K)(N.m)	Rated torque $T_N$ (100K)(N.m)	19.1	28.65	35	47.76
最大转速 $n_{max\ inv}$ (r/min)	Maximum speed $n_{max\ inv}$ (r/min)	2000	2000	2000	2000
最大电流 $I_{max\ inv}$ (A)	Maximum current $I_{max\ inv}$ (A)	37.4	51.7	64.6	82.5
最大转矩 $T_{max\ inv}$ (N.m)	Maximum torque $T_{max\ inv}$ (N.m)	57.3	85.95	105	143.3
转动惯量 $J$ ( $10^{-4}$ kg.m <sup>2</sup> )	Moment of inertia $J$ ( $10^{-4}$ kg.m <sup>2</sup> )	47.2(58.2)	69.3(80.3)	94.1(105.1)	135.6(146.6)
重量 $m$ (kg)	Weight $m$ (kg)	12.9(17.2)	16.6(20.9)	21.1(25.4)	28.4(32.7)
整机长度 $L$ (mm)	Overall length $L$ (mm)	156(193)	180(217)	205(242)	250(287)

注：括号内为带抱闸的数据

Note: The data in parentheses are with brake

经济型AN系列伺服驱动器

AN general servo drive

11 伺服驱动器概述

11 Servo drive preface

AN系列伺服驱动器是支持Ether-CAT/PROFINET工业以太网的220V伺服驱动器，可支持单相或三相220V供电，支持STO安全转矩关断，采用端子型接线方式，接线更便捷。调试接口采用常用Type-C接口，方便用户接线调试。

The AN series servo drive is a 220V servo drive that supports Ether-CAT/PROFINET industrial Ethernet. It can operate with single-phase or three-phase 220V power supply and supports STO (Safe Torque Off) function. It adopts a terminal-type wiring method, making wiring more convenient. The debugging interface uses the commonly used Type-C interface, facilitating user wiring and debugging.



11.1 伺服驱动器型号表示方法

11.1 Model indication method

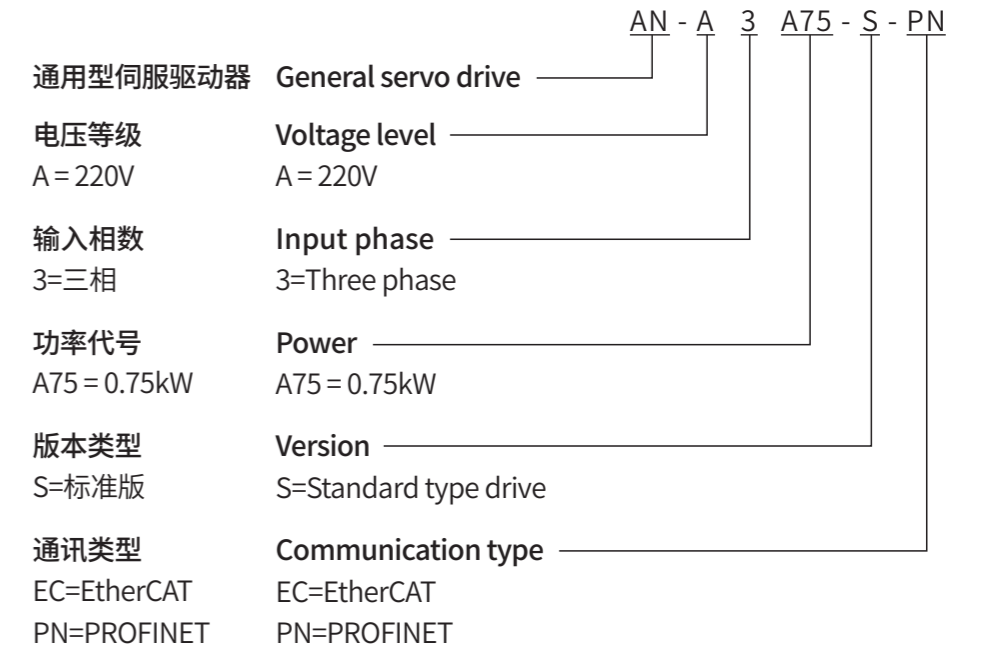

11.2 伺服驱动器订货数据

11.2 Ordering Data

200...240V AC输入		200...240V AC input	
额定数据 rated data		外形尺寸 Dimensions	型号 Order number
额定功率(kW) Power (kW)	额定电流(A) Current (A)		
0.75	6.0	NO	AN-A3A75-S-EC
0.75	6.0	NO	AN-A3A75-S-PN

11.3 伺服驱动器通用技术数据

11.3 general data of AN general servo drive

参数	Parameter	描述	Description
过载能力	Overload capacity	300%	
电磁兼容性	Electromagnetic compatibility	符合IEC 61800-3	According to IEC 61800-3
环境条件 Ambient condition			
运行环境	Operating environment	室内(无阳光直射)、无腐蚀性气体、易燃气体、油气或灰尘	In door, without corrosive gases, flammable gases, dust
环境温度	运行	<p>-20°C~+40°C:无功率降额 +40°C~+55°C:有功率降额</p> <p>-20°C~+40°C:Without current derating +40°C~+55°C:With current derating</p>	<p>-20°C~+40°C:Without current derating +40°C~+55°C:With current derating</p>
	存储	-40°C ~ +70°C	-40°C ~ +70°C
环境湿度	Relative humidity	<95% (无凝露)	<95% (Without ripping water)
海拔	Installation altitude	<p>≤1000m(无功率降额)</p>	≤1000m (Without current derating)
振动	Vibration	符合 IEC 60068-2-6 10Hz~58Hz:0.075mm偏转 58Hz~200Hz:1g振动	According to IEC 60068-2-6 10Hz~58Hz:0.075mm deflection 58Hz~200Hz:1g vibration
冲击	Impact	符合 IEC 60068-2-27 峰值加速度:10g 冲击数量:每方向上 3个x6个方向 冲击持续时间:11ms	According to IEC 60068-2-27 Peak acceleration:10g impact quantity:six impacts on 3 axes in each direction Impact duration:11ms

参数	Parameter	描述	Description
污染等级	Pollution	等级2	degree of pullution 2
噪音排放	Noise intensity	小于60dB	<69dB
防护等级	Protection level	IP20	IP20
输入输出信号 Input and output signals			
数字量输入信号	Digital input signal	5路公共端子COM的DI 电气隔离 支持Source和Sink模式 最大电压:DC 30V "1"信号电压:>15V "0"信号电压:<5V 24V典型电流:4mA	DI of 5-way common terminal COM Electrical isolation supports Source and Sink modes maximum voltage:DC 30V "1"Signal voltage:>15V "0" Signal voltage:<5V 24V Typical current:4mA
数字量输出信号	Digital output signal	2路开集电极DO输出、 1路固态继电器输出 最大电压:DC 30V 最大电流:开集电极输出 为50mA, 固态继电器输出为2A	2-way open collector DO One-way solid-state relay output maximum voltage:DC 30V maximum current:open collector output 50mA Solid-state relay output 2A
LED显示功能	LED display function	主电源带电指示, 5位LED显示	Main power supply live indication, 5-digit LED display
调试	Debug	通过USB调试参数	Debugging parameters through USB

11.4 伺服驱动器特定技术数据

11.4 Technical data for servo drives

AN系列	AN series servo drive	0.75kW	0.75kW
		A3A75	A3A75
主电源	电压	1AC/3AC 200V~240VAC, ±10%	1AC/3AC 200V~240VAC, ±10%
	频率	47Hz~63Hz	47Hz~63Hz
输入电流(A)		5.9(3AC)/8.4(1AC)	5.9(3AC)/8.4(1AC)
连续输出电流(A)		6.0	6.0
瞬时最大输出电流(A)		18.0	18.0
冷却方式		风扇冷却	Fan cooling
制动电阻		内置(40Ω/50W)	Built in(40Ω/50W)
短路电流		最大短路电流≤65kA	Maximum short-circuit current ≤ 65kA
尺寸(宽×高×深, mm)		46×171×173	46×171×173
重量(kg)		0.9	0.9

11.5 接口端子信号定义

主电源进线端子

采用带固定卡扣的脱落式端子, 引脚间距5.0mm, 线径范围0.2~2.5mm<sup>2</sup>。

11.5 Interface signal definitions

Main power input terminal:

Utilizes detachable terminals with fixed latch, pin spacing of 5.0mm, wire diameter range of 0.2~2.5mm<sup>2</sup>.

端子位置 Terminal number	引脚序号 Pin number	信号名称 Signal name	功能定义 Function definition
X3	1	L1	连接电源 Input power supply
	2	L2	
	3	L3	
	4	P	直流母线正 Positive terminal of DC busbar
	5	D	内置制动电阻 built-in braking resistor
	6	B	外置制动电阻 External braking resistor
	7	N	直流母线负 Negative terminal of DC busbar
	8	U	连接电机 Connect servo motor
	9	V	
	10	W	

安全功能端子

采用带固定螺丝的脱落式端子, 引脚间距3.5mm, 线径范围0.5~1.5mm<sup>2</sup>。

Safety function terminals:

Utilizes detachable terminals with fixed screws, pin spacing of 3.5mm, wire diameter range of 0.5~1.5mm<sup>2</sup>.

端子位置 Terminal number	引脚序号 Pin number	信号名称 Signal name	功能定义 Function definition
X1	1	S0V	安全功能 24V电源 Safety function 24V power supply
	2	S24V	
	3	ST01	两路安全功能输入 Dual-channel safety function signal input
	4	ST02	

数字量输入输出端子

采用压线式接线端子端子, 引脚间距3.5mm, 线径范围0.5~1.5mm<sup>2</sup>。

Digital input/output terminals:

Use crimp-type terminal blocks. pin spacing of 3.5mm, wire diameter range of 0.5~1.5mm<sup>2</sup>.

端子位置 Terminal number	引脚序号 Pin number	信号名称 Signal name	功能定义 Function definition
X2	5	DI0	数字量输入 Digital input
	7	DI1	
	9	DI2	
	11	DI3	
	13	DI4	
	3	M	输出24V电源 24V output power supply
	2	24V	
	1	0V	数字量输出 Digital output
	4	D00+	
	6	D00-	
	8	D01+	
	10	D01-	
	12	D02+	
	14	D02-	

编码器端子

采用RJ45端子。

Encoder terminals:

Utilizes RJ45 female socket.

端子位置 Terminal number	引脚序号 Pin number	信号名称 Signal name	功能定义 Function definition
X10	1	TEMP+	温度采样 Motor temperature detection
	2	TEMP-	
	3	CK+	编码器时钟信号 Encoder clock signal
	4	RS485_B	编码器数据信号 Encoder data signal
	5	RS485_A	
	6	CK-	编码器时钟信号 Encoder clock signal
	7	+5V	编码器5V供电电源 Encoder 5V power supply
	8	GND	

调试端子

采用标准TYPE-C USB通用端子。

Debugging terminals:

Utilizes standard TYPE-C USB interface.

PN通讯端子

采用RJ45母座。

Communication terminals:

Utilizes RJ45 female socket.

端子位置 Terminal number	引脚序号 Pin number	信号名称 Signal name	功能定义 Function definition
X20	1	TD+	数据发送+ Data transmission +
	2	TD-	数据发送- Data transmission -
	3	RD+	数据接收+ Data reception +
	4	-	-
	5	-	-
	6	RD-	数据接收- Data reception -
	7	-	-
	8	-	-
X21	1	TD+	数据发送+ Data transmission +
	2	TD-	数据发送- Data transmission -
	3	RD+	数据接收+ Data reception +
	4	-	-
	5	-	-
	6	RD-	数据接收- Data reception -
	7	-	-
	8	-	-

11.6 端子配线图

11.6 Servo drive terminal connection

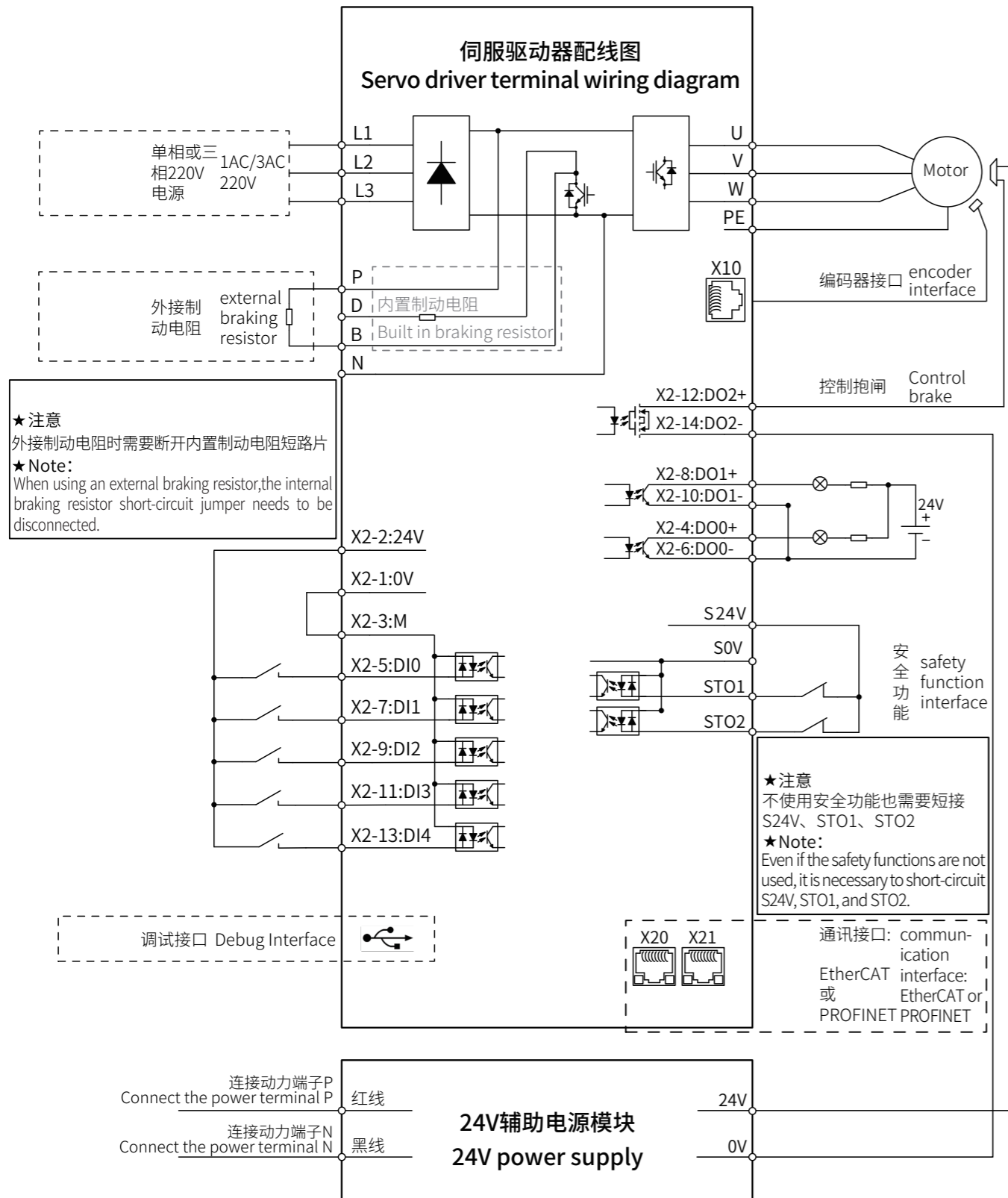

12 整机外形及安装尺寸图

12 Overall appearance and installation dimension diagram

整机外形图及安装尺寸图，单位：mm

Overall appearance diagram and installation dimension diagram, unit: mm

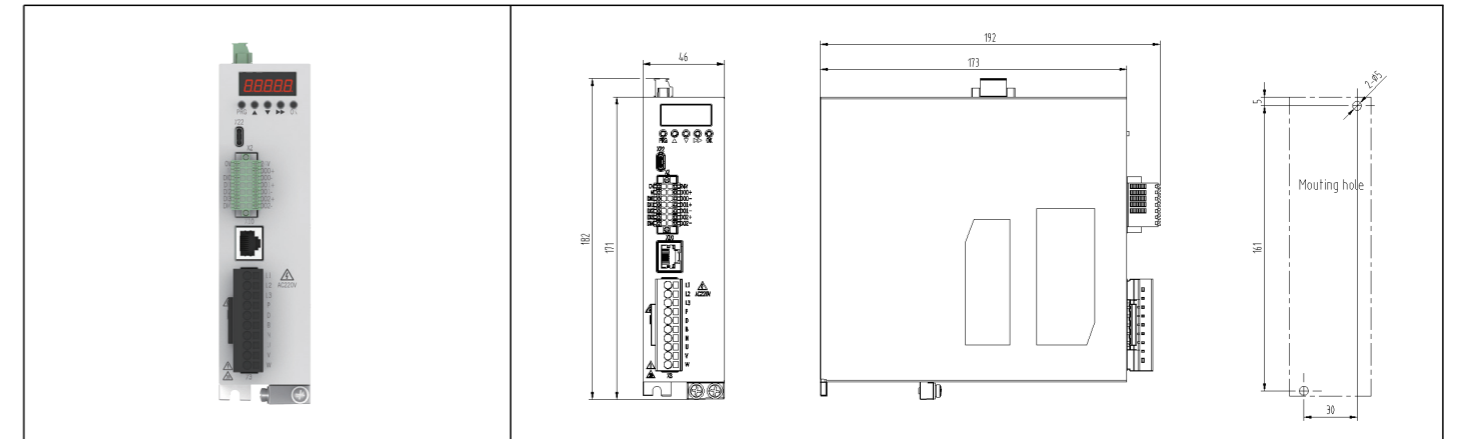

13 可选件

13 Incoming Reactor

13.1 进线电抗器

13.1 Incoming Reactor

当系统的故障率高时，需要加装进线电抗器以保护驱动器不受过大的谐波电流的干扰，改善驱动器的输入侧功率因数；防止过载，并将进线谐波限制在允许的值内，以确保驱动器达到期望的使用寿命。AN系列驱动器可选的进线电抗器推荐型号如下表：

When the failure rate of the system is high, it is necessary to install an incoming reactor to protect the driver from the interference of large harmonic currents and improve the input power factor of the driver; Prevent overloading and limit incoming harmonics within allowable values to ensure that the driver reaches the expected service life. The recommended models of incoming reactors for AN series drives are as follows:

框架 Dimensions	伺服驱动器型号 Order number	额定 Rated 电流 current	电感 Inductance	订货号 Ordering Data
		(A)	(mH)	
NO	AN-A3A75-S-EC	10	1.4	A1-H12-TB140
NO	AN-A3A75-S-PN	10	1.4	A1-H12-TB140

### 13.2 进线滤波器

进线滤波器的作用是抑制驱动器通过输入电源线所传输到公共电网中的电磁干扰,同时也衰减从电源线进入驱动器的干扰;在安装时请尽量靠近驱动器的输入端子侧进行安装,请使用驱动器专用的进线滤波器。AN系列驱动器可选的进线滤波器推荐型号如下表:

框架 Dimensions	伺服驱动 器型号 Order number	额定 电流 Rated current	订货号 Ordering Data
		(A)	
NO	AN-A3A75-S-EC	10	A1-H11-A-C10-□
NO	AN-A3A75-S-PN	10	A1-H11-A-C10-□

无后缀 三相 220V  
A 单相 220V  
No suffix Three-phase 220V  
A Single-phase 220V

### 13.3 制动电阻

制动电阻用于使大转动惯量的负载迅速制动。在电机和负载制动时,动能转换成的再生电能会返回到驱动器中,直流母线电压因此抬高,驱动器将这些再生的能量几乎全部消耗在制动电阻上;AN系列驱动器可选的制动电阻推荐规格如下:

### 13.2 Incoming filter

The function of the incoming filter is to suppress the electromagnetic interference transmitted by the driver through the input power line to the public power grid, while also attenuating the interference entering the driver from the power line; When installing, please try to install it as close to the input terminal side of the driver as possible, and use a dedicated input filter for the driver. The recommended models for optional incoming line filters for AN series drives are shown in the table below:

### 13.3 Braking resistor

The braking resistor is used to quickly brake a load with a large moment of inertia. During motor and load braking, the regenerated energy converted from kinetic energy will return to the driver, causing the DC bus voltage to rise. The driver will consume almost all of this regenerated energy on the braking resistor; The recommended specifications for the optional braking resistor of the AN series driver are as follows:

驱动器 Servo driver model		允许的 最小 制动阻	2%ED的非频繁制动应用场合 2% ED for non frequent braking applications			20%ED的频繁制动应用场合 20% ED for frequent braking applications			
框架	伺服驱动器型号		功率 (kW)	阻值 (Ω)	博能内置 制动电阻	推荐值 Recommended value		博能订货型号 Boneng ordering model	
Dimen- sions	Order number	Allow minimum resistance value	Power (KW)	Resist- ance value (Ω)	Built in braking resistor	功率 (kW) Power (KW)	阻值 (Ω) Resistance value(Ω)	订货号 Ordering Data	等效制动电阻 Equivalent break- ing resistance
NO	AN-A3A75-N-EC	40 Ω	0.05	40	50W 40 Ω	0.40	75	A1-H02-A40-K-C75	400W 75 Ω
NO	AN-A3A75-N-PN	40 Ω	0.05	40	50W 40 Ω	0.40	75	A1-H02-A40-K-C75	400W 75 Ω

#### 制动电阻接线注意事项:

- 使用外接制动电阻时请将P、D之间短接线拆除,否则会导致制动管过流损坏;
- 请勿将外接制动电阻直接接到母线正负极,否则会导致炸机和跳闸;
- 请勿小于最小允许阻值,否则会导致过流报警或损坏驱动器

#### Precautions for brake resistor wiring:

- When using an external brake resistor, please remove the short circuit between P and D, otherwise it may cause overcurrent damage to the brake IGBT;
- Do not directly connect the external braking resistor to the positive and negative poles of the bus, otherwise it may cause the machine to explode and trip;
- Do not exceed the minimum allowable resistance value, otherwise it may cause over-current alarm or damage to the drive;

随着技术迭代进步,博能产品样本将会同步更新,请见谅。  
Along with the technology advancedet.,the product of  
the manual of Boneng will be changed,please forgive.

控制层 CONTROL

驱动层 DRIVE

马达层 MOTOR

齿轮层 GEAR



X3010 PLC

EtherCAT&Modbus  
24VDC



X3050 运动控制器  
Motion Controller

EtherCAT&Modbus  
24VDC

C/F/K/S-M  
\* . . . D  
马达分布式  
变频驱动器  
Integrated  
Gearmotor  
Drive

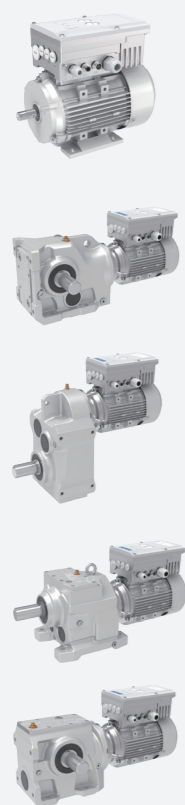

EtherCAT &  
Modbus  
380~480VAC  
0.25~3kW  
i=4~355

AM 变频驱动器  
Variable Frequency Drive



Modbus  
380~480VAC  
0.75~5.5kW

A1 变频驱动器  
Variable Frequency Drive



Modbus/CANopen  
/PROFINET  
380~480VAC  
0.75~250kW

C/F/K/S/R  
齿轮马达  
Gearmotor



380~480VAC  
0.09~200kW  
i=1.25~500

MP/MU  
三相交流异步马达  
Asynchronous Motor



380~480VAC  
0.09~90kW  
960/1450r/min  
1160/1750r/min

HB/BE/HK  
齿轮箱  
Gearbox



4.2~15775kW  
i=5.6~450

P/PK  
行星齿轮箱  
Planetary  
Gearbox

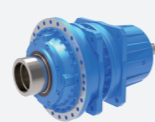

0.4~14000kW  
i=25~4000

PW  
卷扬齿轮箱  
Planetary  
Winch  
Gearbox

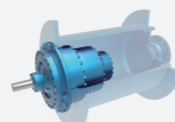

1~1810kW  
i=13~940

PS  
回转齿轮箱  
Planetary  
Slewing  
Gearbox



1~1626kW  
i=14~947

J/JB  
升降机  
Jack



0.35~22.63kW  
i=5~34

T  
转向箱  
Spiral Bevel  
Gearbox

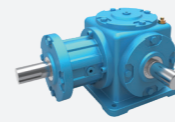

0.08~303kW  
i=1:1~3:1

MX&AX  
伺服马达&伺  
服驱动器  
Permanent  
Magnet  
Servo Motor  
& Servo Drive



EtherCAT/  
PROFINET  
380~480VAC  
0.28~103kW  
1500/2000r/min  
3000/4500r/min

C/F/K-MX  
&AX齿轮伺  
服马达&伺  
服驱动器  
Servo  
Gearmotor  
& Servo Drive

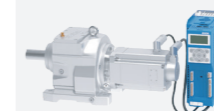
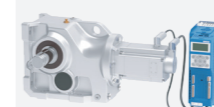

PX-MX&AX  
行星伺服马达  
&伺服驱动器  
Planetary  
Precision Gear  
Servo Motor  
& Servo Drive



PN-MN&AN  
行星伺服马达  
&伺服驱动器  
Planetary  
Precision Gear  
Servo Motor  
& Servo Drive



ME&AN  
永磁同步伺服马  
达&伺服驱动器  
Permanent  
Magnet  
Servo Motor  
& Servo Drive



EtherCAT/  
PROFINET  
200~240VAC  
0.1kW~7.5kW

EtherCAT/  
PROFINET  
380~480VAC  
0.28~103kW  
i=1.25~315

EtherCAT/  
PROFINET  
380~480VAC  
0.38~10.06kW  
i=3~100

EtherCAT  
PROFINET  
380~480VAC  
0.28~5.03kW  
i=3~100

<b>博能传动(沈阳)有限公司</b>	<b>BONENG TRANSMISSION(SHENYANG)CO.,LTD.</b>
辽宁省沈阳市沈北新区 太平洋工业城A区A73-6号 电话: 024-31271571	No. A73-6, Area A, Pacific Industrial City, Shenbei New District, Shenyang, Liaoning Province, China TEL: 024-31271571

<b>博能传动(天津)有限公司</b>	<b>BONENG TRANSMISSION(TIANJIN)CO.,LTD.</b>
天津市北辰区双海道6号 宏鹏工业园7号车间 电话: 022-26929556	7th Workshop, Hongpeng Industrial Park, No. 6 Shuanghai Road, Beichen District, Tianjin City,China TEL: 022-26929556

<b>博能传动(潍坊)有限公司</b>	<b>BONENG TRANSMISSION(WEIFANG)CO.,LTD.</b>
山东省潍坊市安丘市经济开发区 汶水路与昆仑大街交叉口往北 100米路东1号车间 电话: 0536-2141166	1st Workshop, Economic Development Zone, Anqiu, Weifang City, Shandong Province, China TEL: 0536-2141166

<b>博能传动(开封)有限公司</b>	<b>BONENG TRANSMISSION(KAIFENG)CO.,LTD.</b>
河南省开封市宋城路四大街11号 海神机械院内五号厂房 电话: 0371-23335238	5th Workshop, Haishen Machinery, No.11, Fourth Street, Songcheng Road,New District, Kaifeng City, Henan Province, China TEL: 0371-23335238

<b>博能传动(长沙)有限公司</b>	<b>BONENG TRANSMISSION(CHANGSHA)CO.,LTD.</b>
湖南省长沙市望城经济开发区 普瑞大道1288号 电话: 0731-88386958	No. 1288 Puri Avenue, Wangcheng Economic Development Zone, Changsha City, Hunan Province, China TEL: 0731-88386958

<b>博能传动设备(成都)有限公司</b>	<b>BONENG TRANSMISSION EQUIPMENT(CHENGDU) CO., LTD.</b>
四川省成都市金牛区金牛坝路9号5栋 向荣中心A座7楼-703 电话: 028-87741100	703, 7th Floor, Block A, Xiangrong Center, Building 5, No. 9 Jinniuba Road, Jinniu District, Chengdu City, Sichuan Province, China TEL: 028-87741100

<b>博能传动(肇庆)有限公司</b>	<b>BONENG TRANSMISSION(ZHAOQING)CO.,LTD.</b>
广东省肇庆市鼎湖区肇庆新区 科创大道7号平谦国际现代产业园 一期A12北厂房 电话: 0757-86719757	No. 7 Science and Technology Innovation Avenue, Zhaoqing New Area, Dinghu District, Zhaoqing City, Guangdong Province, China TEL: 0757-86719757

<b>博能传动(苏州)有限公司</b>	<b>BONENG TRANSMISSION(SUZHOU)CO.,LTD.</b>
江苏省苏州市相城区如元路100号 电话: 0512-66189662	No. 100, Ruyuan Road, Xiangcheng District, Suzhou, Jiangsu Province, China TEL: 0512-66189662

<b>博能传动(美国)有限公司</b>	<b>BONENG TRANSMISSION(USA)LLC.</b>
1250 E 222nd Euclid, OH 44117, United Staes TEL: 1-216-618-0138 TEL: 1-216-618-0496 TEL: 1-216-618-3099	1250 E 222nd Euclid, OH 44117, United Staes TEL: 1-216-618-0138 TEL: 1-216-618-0496 TEL: 1-216-618-3099

<b>博能传动(印度)有限公司</b>	<b>BONENG TRANSMISSION(INDIA)PVT.LTD</b>
Plot No. E-10/3, MIDC sinnar (Malegaon) Industrial Area, Nashik, 422123, Maharashtra, India. TEL:+91-11- 4507 6293 (DELHI) TEL:+91-22-2781 3385 (MUMBAI)	Plot No. E-10/3, MIDC sinnar (Malegaon) Industrial Area, Nashik, 422123, Maharashtra, India. TEL:+91-11- 4507 6293 (DELHI) TEL:+91-22-2781 3385 (MUMBAI)