

BONENG

MP/MU三相交流异步马达

MP/MU Three-Phase Asynchronous Motor

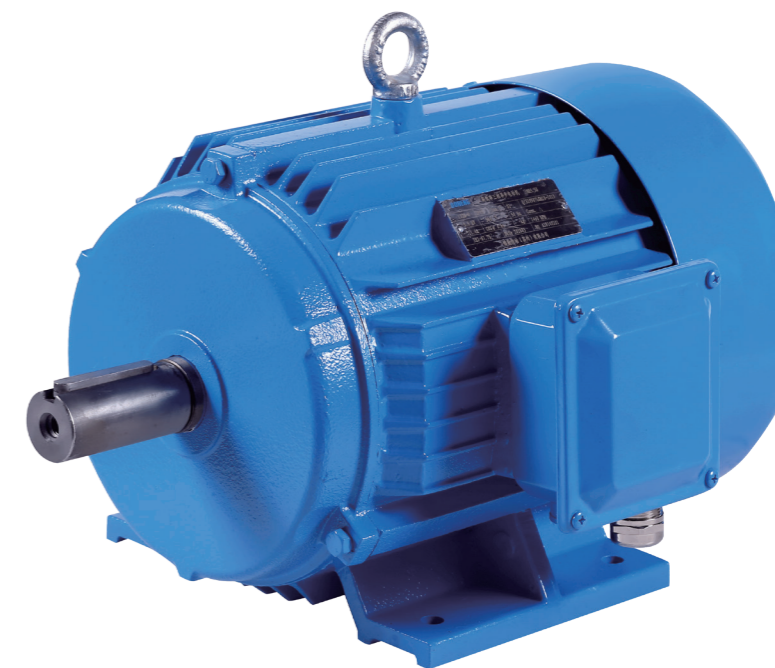

**MP/MU三
相交流异步马达**

功率：0.09kW~90kW；
机座号：56~280

**MP/MU
Three-Phase
Asynchronous Motor**

Power: 0.09kW~90kW；
Frame Size: 56~280

Modified date 05/2026
Selection Sample C05.0008

BONENG

Boneng Transmission



控制器/驱动器/马达/齿
轮马达/齿轮箱

Controller/ Drive/ Motor/
Gearmotor/ Gearbox

MP/MU三 相交流异步马达

- ◆ 灵活多变的模块组合给用户带来简约、丰富选择；
- ◆ 满足全工作制、A类和B类工频电网、逆变电源下的可靠运行具备超强的适应性；
- ◆ 先进的磁路设计及有限元分析确保了产品的一致性、可靠性；
- ◆ R级的噪音振动、B级或E级的温升、IE3/IE4的效率等级大幅度提升了产品寿命；
- ◆ 先进的自动化电加工生产线、VPI浸漆、苛刻的内部综合实验和检测确保给用户高性能的产品；
- ◆ 标准化、模块化、多区域服务的理念可实现更快的交货期；
- ◆ 延长产品生命周期，免维护的设计理念，使我们的产品在整個生命周期内的性价得以凸显；
- ◆ 在产品生命周期内除密封件外无需额外的维护，大大减少了用户的维保成本

MP/MU Three-Phase Asynchronous Motor

- ◆ Flexible and variable module combination brings simple and rich choices to users.
- ◆ Can reliable operation under all working system, Class A and Class B common power frequency grid and inverter power supply with superior adaptability.
- ◆ Advanced magnetic circuit design and finite element analysis ensure product consistency and reliability.
- ◆ R-level noise vibration, B-class or E-class temperature rise, and IE3/IE4 efficiency grade greatly improve product life.
- ◆ Advanced automated electric processing production line, VPI dip coating, demanding internal comprehensive experiment and inspection to ensure high performance products for users.
- ◆ The idea of standardization, modularization and multi-regional service can achieve faster delivery.
- ◆ Extend the product life cycle and maintenance-free design concept, so that the cost performance of our products throughout the life cycle can be highlighted.
- ◆ No additional maintenance is required in addition to the seals during the product life cycle.



产品广泛应用于电力、采矿、水泥、造纸、食品、物流等各个领域。

博能传动公司总部和各大区域的技术专家以及各区域办事处的应用工程师、售后服务技师竭诚为您提供全面的技术咨询和完美的服务。

Products are widely used in Power, Mining, Cement, Paper, Food, Logistics and other fields. Boneng Transmission company headquarters and major regional technical experts and regional offices of the application engineers, after-sales service technicians dedicated to provide you with comprehensive technical advice and perfect service.

目录

Contents

注意事项:

- ◆ 样本中的结构示意图、外形图及其他附图只属范例，无严格比例要求。（未注尺寸单位均为mm）。
- ◆ 所注重量仅为平均值，并不具有约束力。

⚠ 必须严格遵守以下各项:

- ◆ 为防止意外事故发生，所有旋转部件均按照使用者所在国家和地区的安全规范由购置方加罩保护。
- ◆ 试车之前必须认真阅读使用说明书。

Notes:

- ◆ The structure scheme, appearance diagram and other attached diagrams in sample are examples, there is no strict proportion requirement. (The unmarked dimension units are mm).
- ◆ The marked weight is average value, it has no constraint force.

⚠ The following items must be strictly observed:

- ◆ To prevent accidents, all the rotation parts are added with protective covers by the purchaser according to the safety regulations of the nation and region.
- ◆ The instruction book must be read carefully before the test run.

01.概述	01	01.Overview	01
02.参考标准	05	02.Reference standards	05
03.机械特性	06	03.Mechanical design	06
04.电气特性	09	04.Electrical design	09
05.可选件	13	05.Options	13
06.变频应用	19	06.Frequency conversion applications	19
07.MP/MU马达型号 表达方法	20	07.MP/MU motor type Designation	20
08.MP马达选型技术参数	23	08.MP motor selection technical data(IE3 Energy Efficiency)	23
09.MU马达选型技术参数	27	09.MU motor selection technical data(IE4 Energy Efficiency)	27
10.MP马达外形尺寸	31	10.MP motor dimensions	31
11.MU马达外形尺寸	35	11.MU motor dimensions	35
12.马达尾部出轴与防雨罩尺寸	39	12.Dimensions of motor shaft projecting tail and rainproof cover	39
13.电气连接原理图	40	13. Electrical connection schematics	40

1 概述

博能三相交流异步马达是通用型全封闭自扇冷却或强制冷却式三相异步马达，其标配防护等级为IP55，设计生产符合IEC、GB等相关标准的要求。适用于连续工作制（S1）、恒转速或一定速度范围内的变频调速应用，同时也满足大部分断续工作方式（S2-S10）恒转速或一定速度范围内的变频调速应用。

1.1 技术特性

- ◆ 机座材料：
H56-100：压铸铝；
H112-280：灰铸铁；
- ◆ 额定功率：0.09 kW-90kW。
- ◆ 马达极数：4、6
- ◆ 马达效率：满足 IEC 60034-30 标准中的IE4、IE3效率等级,达到GB18613-2020标准能效等级2、3级。
- ◆ 标准安装结构类型（符合IEC 60034-7标准规定）：IMB3、IMB5、IMB14B、IMB35、IMB34B等。
- ◆ 马达防护等级：防护等级为IP55(IEC60034-5)。
- ◆ 马达绝缘等级：绝缘系统按155°C(F)温度等级设计，按130(B)温度等级考核，H级绝缘(可选)；根据IEC 60034-1划分的温升等级，温升限值如下(电阻法测量)。

绝缘等级 Insulation class	温升等级 (K) Temperature rise level (K)		
	温度计法 Thermometer method	电阻法 Resistance method	嵌温计法 Embedded thermometer method
B	70	80	85
F	85	100	105
H	105	125	130

1 Overview

BONENG three-phase asynchronous motor is a universal closed-fan cooling or forced-cooled three-phase asynchronous motor, the standard protection class IP55, the design and production in line with IEC, GB and other related standards. Apply to continuous work system (S1), constant speed or speed within a certain range of frequency control applications, but also to meet most of the intermittent work (S2-S10), constant speed or speed within a certain range of frequency control applications.

1.1 Technical Design

- ◆ Frame material：
H56-100: Die-casting aluminum;
H112-280: grey cast iron;
- ◆ Rated power: 0.09 kW-90 kW.
- ◆ Number of motor poles: 4, 6
- ◆ Motor efficiency: Meet the IEC 60034-30 standard IE4, IE3 efficiency level, and to Meet GB18613-2020 standard energy efficiency grade 2, 3.
- ◆ Standard mounting structure (Compliance with standards IEC 60034-7): IMB3, IMB5, IMB14B, IMB35, IMB34B, etc.
- ◆ Motor Degree of Protection: Protection class IP55 (IEC 60034-5).
- ◆ Motor Insulation class: Insulation system designed according to the temperature level of 155°C (F), by 130 (B) temperature level assessment, H-class insulation (optional); The temperature rise limits according to IEC 60034-1 are as follows (resistance method).

- ◆ 马达热保护：可选 PTC热敏电阻、热敏开关 或 PT100 温度传感器进行绕组保护。
- ◆ 马达接线盒：从马达尾部看，接线盒标准位置处于机座左侧，进线孔朝下，接线盒位置和进线方向可根据客户需求选择。
- ◆ 马达接线盒进线孔：马达接线盒进线孔 H56~H80 为一个，H90~H280 为两个。
- ◆ 马达冷却方式：马达标准冷却方式为自扇冷却 (IEC 60034-6 规定的 IC 411)，可提供独立风机强制冷却和自然冷却的马达。

1.2 运行环境

- ◆ 马达标准运行环境
高度不超过海拔1000m (IEC 60034-1)；
允许的环境温度在 -20°C ~40°C (IEC 60034-1)；
所允许的相对湿度：
-20°C ≤ T ≤ 20°C: 100%
20°C < T ≤ 30°C: 95%
30°C < T ≤ 40°C: 55%
- ◆ 对于更高的环境温度、以及(或者)高于海拔1000m的地点，马达的额定功率换算系数为KHT
PN' : PN' = PN . KHT

对于不同高度和(或)不同环境温度的功率折算系数KHT

Ambient temperature Altitude above sea level	<30°C	30~40°C	45°C	50°C	55°C	60°C
1000 m	1.07	1	0.96	0.92	0.87	0.82
1500 m	1.04	0.97	0.93	0.89	0.84	0.79
2000 m	1	0.94	0.9	0.86	0.82	0.77
2500 m	0.96	0.9	0.86	0.83	0.78	0.74
3000 m	0.92	0.86	0.82	0.79	0.75	0.7
3500 m	0.88	0.82	0.79	0.75	0.71	0.67
4000 m	0.82	0.77	0.74	0.71	0.67	0.63

- ◆ Motor thermal protection: Optional PTC thermistor, thermal switch or PT100 temperature sensor for winding protection.
- ◆ Motor terminal box: From the motor tail, the standard position of the terminal box is on the left side of the frame, with the cable entry facing down. Terminal box location and cable entry can be selected according to the customer requirements.
- ◆ Motor terminal box cable entry: Motor cable entry H56-80 for one, H90-280 for two.
- ◆ Motor cooling method: Motor cooling is radial-flow fans cooled (IC 411 as specified in IEC 60034-6) and provide the motor that independently drives fan for forced cooling and natural cooling.

1.2 Operating environment

- ◆ Motor standard operating environment
Operating altitude does not 1000 m above sea level (IEC 60034-1)；
Allowable working environment temperature -20°C-40°C (IEC 60034-1)；
Permitted relative humidity:
-20°C ≤ T ≤ 20°C: 100%
20°C < T ≤ 30°C: 95%
30°C < T ≤ 40°C: 55%
- ◆ For higher ambient temperatures and / or locations 1000 m above sea level, the specified motor output must be reduced by using the factor KHT. The results in an admissible output (Padm) of the motor:
PN' : PN' = PN . KHT

Factor KHT for different side altitudes and / or ambient temperature

1.3 铭牌信息示例

The image shows three examples of motor nameplates. Each nameplate contains technical specifications such as power (kW), voltage (V), frequency (Hz), current (A), speed (r/min), efficiency (EFF), and insulation class (IE-CL). The callouts 1-22 correspond to the items listed in the adjacent table.

1.4 马达能效

- ◆ IEC60034-30-1标准, 马达能效适用范围为:
1000 V以下50/60Hz三相交流电源供电的马达;
功率为0.12 kW~1000 kW的2, 4, 6, 8极单速马达;
N设计的连续工作制(S1)的马达。
- ◆ IEC60034-30-1能效等级:

IEC 60034-30-1	GB18613-2020
IE3	3级能效 Grade 3 Energy Efficiency
IE4	2级能效 Grade 2 Energy Efficiency
IE5	1级能效 Grade 1 Energy Efficiency

1.3 Nameplate information

1. 马达系列 (规格)
2. 机座号
3. 安装方式
4. 防护等级
5. 绝缘等级
6. 工作制
7. 企业标准
8. 额定功率
9. 额定电压
10. 额定频率
11. 额定电流
12. 额定转速
13. 接法
14. 功率因数
15. 效率
16. 能效等级
17. 重量
18. 出厂日期
19. 出厂编号
20. 制动电压/转矩
21. 恒转矩范围
22. 恒功率范围

1.4 Motor Energy Efficiency

- ◆ According to IEC 60034-30-1 standard, the scope of motor energy efficiency is:
Motor under 1000V, 50 / 60Hz three-phase AC power supply;
2, 4, 6, 8 pole single-speed motor with power of 0.12 kW ~ 1000kW;
N designed continuous working system (S1) motor.
- ◆ IEC60034-30-1 Energy efficiency rating:

IEC60034-30-1标准, 马达能效(η%): IEC60034-30-1standard, Motor energy efficiency(η%):

功率 Power (KW) (W)	IE2-50Hz		IE3-50Hz		IE4-50Hz	
	4-pole	6-pole	4-pole	6-pole	4-pole	6-pole
0.12	59.1	50.6	64.8	57.7	69.8	64.9
0.18	64.7	56.6	69.9	63.9	74.7	70.1
0.2	65.9	58.2	71.1	65.4	75.8	71.4
0.25	68.5	61.6	73.5	68.8	77.9	74.1
0.37	72.7	67.6	77.3	73.5	81.1	78
0.4	73.5	68.8	78	74.4	81.7	78.7
0.55	77.1	73.1	80.8	77.2	83.9	80.9
0.75	79.6	75.9	82.5	78.9	85.7	82.7
1.1	81.4	78.1	84.1	81	87.2	84.5
1.5	82.8	79.8	85.3	82.5	88.2	85.9
2.2	84.3	81.8	86.7	84.3	89.5	87.4
3	85.5	83.3	87.7	85.6	90.4	88.6
4	86.6	84.6	88.6	86.8	91.1	89.5
5.5	87.7	86	89.6	88	91.9	90.5
7.5	88.7	87.2	90.4	89.1	92.6	91.3
11	89.8	88.7	91.4	90.3	93.3	92.3
15	90.6	89.7	92.1	91.2	93.9	92.9
18.5	91.2	90.4	92.6	91.7	94.2	93.4
22	91.6	90.9	93	92.2	94.5	93.7
30	92.3	91.7	93.6	92.9	94.9	94.2
37	92.7	92.2	93.9	93.3	95.2	94.5
45	93.1	92.7	94.2	93.7	95.4	94.8
55	93.5	93.1	94.6	94.1	95.7	95.1
75	94	93.7	95	94.6	96	95.4
90	94.2	94	95.2	94.9	96.1	95.6
110	94.5	94.3	95.4	95.1	96.3	95.8
132	94.7	94.6	95.6	95.4	96.4	96
160	94.9	94.8	95.8	95.6	96.6	96.2
200	95.1	95	96	95.8	96.7	96.3
250	95.1	95	96	95.8	96.7	96.5
315-1000	95.1	95	96	95.8	96.7	96.6
功率 Power (KW) (W)	IE2-60Hz		IE3-60Hz		IE4-60Hz	
	4-pole	6-pole	4-pole	6-pole	4-pole	6-pole
0.12	64	50.5	66	64	70	68
0.18	68	55	69.5	67.5	74	72
0.25	70	59.5	73.4	71.4	77	75.5
0.37	72	64	78.2	75.3	81.5	78.5
0.55	75.5	68	81.1	81.7	84	82.5
0.75	82.5	80	85.5	82.5	85.5	84
1.1	84	85.5	86.5	87.5	87.5	88.5
1.5	84	86.5	86.5	88.5	88.5	89.5
2.2	87.5	87.5	89.5	89.5	91	90.2
3.7	87.5	87.5	89.5	89.5	91	90.2
5.5	89.5	89.5	91.7	91	92.4	91.7
7.5	89.5	89.5	91.7	91	92.4	92.4
11	91	90.2	92.4	91.7	93.6	93
15	91	90.2	93	91.7	94.1	93
18.5	92.4	91.7	93.6	93	94.5	94.1
22	92.4	91.7	93.6	93	94.5	94.1
30	93	93	94.1	94.1	95	95
37	93	93	94.5	94.1	95.4	95
45	93.6	93.6	95	94.5	95.4	95.4
55	94.1	93.6	95.4	94.5	95.8	95.4
75	94.5	94.1	95.4	95	96.2	95.8
90	94.5	94.1	95.4	95	96.2	95.8
110	95	95	95.8	95.8	96.2	96.2
150	95	95	96.2	95.8	96.5	96.2
185	95	95	96.2	95.8	96.5	96.2
220	95.4	95	96.2	95.8	96.8	96.5
250-335	95.4	95	96.2	95.8	96.8	96.5
375-1000	95.8	95	96.2	95.8	96.8	96.5

2 参考标准

2 Reference standards

名称	Name	IEC 标准	IEC standard	中国国家标准	Chinese national standard
旋转电机定额和性能	Rotating electrical machines-Rating and performance	IEC 60034-1		GB 755	
旋转电机损耗与效率确定的标准测试方法	Rotating electrical machines Standard methods for determining losses and efficiency from tests	IEC 60034-2		GB/T 1032	
旋转电机整体结构的防护等级 (IP 代码) 分级	Degrees of protection provided by the integral design of rotating electrical machines (IP code) classification	IEC 60034-5		GB/T 4942.1	
旋转电机冷却方法	Cooling methods for rotating electrical machines	IEC 60034-6		GB/T 1993	
旋转电机结构型式、安装型式及接线盒位置的分类 (IM 代码)	Classification of types of construction and mounting arrangements for rotating electrical machines (IM code)	IEC 60034-7		GB/T 997	
旋转电机线端标志与旋转方向	Rotating electrical machines-Terminal marking and direction of rotation	IEC 60034-8		GB/T 1971	
旋转电机噪声测定方法及限值第3部分: 噪声限值	Measurement of airborne noise emitted by rotating electrical machines and the noise limits - Part 3:Noise limits	IEC 60034-9		GB/T 10069.3	
轴中心高为56mm及以上电机的机械振动的测量、评定及限值	Mechanical vibration of certain machines with shaft heights 56 mm and higher-measurement, evaluation and limits of vibration severity	IEC 60034-14		GB/T 10068	
旋转电机尺寸和输出功率等级第1部分:机座号56-400和凸缘号55-1080	Dimensions and output series for rotating electricalmachines-Part 1:Frame numbers 56 to 400 and flange numbers 55 to 1080	IEC 60072-1		GB/T 4772.1	
中小型旋转电机安全要求	General requirements for safety of small and medium size rotating electrical machines	/		GB/T 14711	
电气绝缘耐热性和表示方法	Electrical insulation -Thermal evaluation and designation	IEC 60085		GB/T 11021	
电工电子产品自然环境条件 温度和湿度	Environmental conditions appearing in nature of electric and electronic products Temperature and humidity	IEC 60721-2-1		GB/T 4797.1	
标准电压	Standard Voltages	IEC 60038		GB/T 156	

3 机械特性

3 Mechanical design

3.1 接线盒

3.1 Terminal box

接线盒自身可4×90°旋转安装,从而使电缆可以从各个方向进入。56-80机座接线盒有一个进线孔采用葛兰密封;90-280机座接线盒都有两个进线孔,其中一个进线孔采用葛兰密封,另一个进线孔采用螺塞密封。

The terminal box is self-rotating by 4x90°, allowing cables to enter in all directions. 56-80 motor terminal box has one cable entry using gland seal, 90-280 motor terminal box has two cable entries, one of the cable entry with gland seal, the other cable entry using plug seal. Motor terminal box technical parameters see the table below:

马达接线盒技术参数,见下表:

机座号	主接线端子数	接线螺母螺纹规格	外接电缆直径 (mm)	进线孔尺寸 (葛兰+螺塞)
Frame size	Numbers of main terminals	Contact screw thread	Outer cable diameter (mm)	Cable entry size (gland +screwed plug)
56	6	M4	9~15	M25×1.5
63				
71				
80				
90	6	M4	9~15	M25×1.5+M25×1.5
100	6	M4	9~15	
112	6	M5	14~20	M30×2+M30×2
132				
160	6	M6	18~24	M36×2+M36×2
180				
200	6	M8	24~32	M48×2+M48×2
225				
250	6	M10	37~44	M64×2+M64×2
280				

3.2 安装结构型式

3.2 Type of construction

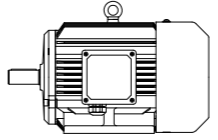
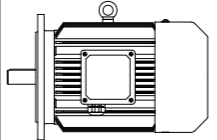
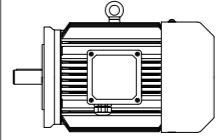
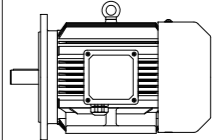
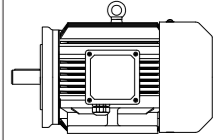
基本结构型式	机座带底脚	端盖带法兰	端盖带小法兰	端盖带法兰机座带底脚	端盖带小法兰机座带底脚
Basic construction	Frame with feet	Cover with flange	Cover with small flange	Cover with flange Frame with feet	Cover with small flange Frame with feet
机座号	63-280	63-280	71-132	63-280	71-132
安装形式	IMB3	IMB5	IMB14B	IMB35	IMB34B
示意图					

3.3 马达轴端孔

机座号	Frame size	驱动端 Drive end	非驱动端 Non-drive end
63		CM4L10/7.4	CM4L10/7.4
71		CM5L10/8.8	CM5L10/8.8
80		CM6L12/10.5	CM8L12/13.2
90		CM8L12/13.2	
100		CM10L15/16.3	
112		CM12L20/19.8	CM10L15/16.3
132			CM10L15/16.3
160		CM16L25/25.3	CM16L25/25.3
180			CM16L25/25.3
200-280		CM20L30/31.3	CM20L30/31.3

3.4 轴承

博能马达标准配置密封深沟球轴承,轴承规格如下:

机座号	Frame size	标准马达轴承规格 Standard motor bearing specifications	
		驱动端 Drive end	非驱动端 Non-drive end
56-63		6201-2Z/C3	6201-2Z/C3
71		6202-2Z/C3	6202-2Z/C3
80		6204-2Z/C3	6204-2Z/C3
90		6205-2Z/C3	6304-2Z/C3
100		6206-2Z/C3	6206-2Z/C3
112		6306-2Z/C3	6206-2Z/C3
132		6308-2Z/C3	6208-2Z/C3
160		6309-2Z/C3	6209-2Z/C3
180		6311-2Z/C3	6211-2Z/C3
200		6312-2Z/C3	6212-2Z/C3
225		6313-2Z/C3	6312-2Z/C3
250		6314-2Z/C3	6314-2Z/C3
280		6317-2Z/C3	6316-2Z/C3

轴承寿命

轴承的标称额定寿命可根据ISO281标准规定的标准计算程序计算出来的。如果马达在该样本中所规定条件下运行,90%甚至更高比例的轴承的运行时间可达到标称寿命。通常,轴承的使用寿命取决于轴承规格、轴承载荷、运行条件、转速以及润滑脂寿命。马达在不受轴向力的情况下,轴承寿命至少能够达到40,000小时。在承受最大容许载荷的情况下,其寿命也至少有20,000小时,这里所说的轴承寿命,指的都是马达在50/60Hz下正常运行的情况。

3.3 Motor shaft end thread

3.4 Bearing

BONENG motor is using deep groove ball bearings for the standard configuration, these bearings are sealed. Bearing specifications are as follows:

Bearing life

The nominal bearing life can be calculated according to the standard calculation procedures specified in ISO 281. If the motor is operated under the conditions specified in this catalog, 90% or more of the bearings will reach the nominal life. Generally, the service life of a bearing depends on the bearing specification, bearing loaded, operating conditions, rotational speed, and grease life. When the motor is installed horizontally and without axial force, the bearing life of the motor can reach at least 40,000 hours. In the case of maximum allowable load, the life of the motor is at least 20,000 hours. The bearing life here refers to the normal operation of the motor at 50/60Hz.

当马达在非正常的条件下运行时,轴承的寿命会缩短。如下面几种情况:

- ◆ 当马达的运行速度高于额定速度时,由于马达的振动增大,使得轴承受到额外的径向力和轴向力,导致其寿命减少;
- ◆ 当环境或设备等因素引起马达振动加大时,同样轴承也会因此受到额外的径向力和轴向力,而导致其寿命减少;
- ◆ 当环境温度每升高10°C,润滑脂寿命以及再润滑时间缩短一半。

3.5 噪声

马达的噪音分为N级(普通级)、R级(一级)、S级(优等级)和E级(低噪音级)四个等级。R级比N级低5dB, S级比N级低10dB, E级比N级低15dB。博能马达噪音值均低于N级规定的噪音值。

- ◆ 马达空载时测得的A计权声功率级噪声值。

When the motor is operating under abnormal conditions, the bearing life will be shortened. Such as the following situations:

- ◆ When the motor speed is higher than the rated speed, due to increased vibration of the motor, making the bearing subjected to additional radial and axial forces, resulting in reduced life expectancy;
- ◆ When the environment or equipment and other factors lead to increased vibration of the motor, the bearing will therefore be subjected to additional radial and axial forces, resulting in reduced life expectancy;
- ◆ When the ambient temperature increases 10°C, grease life and relubrication time will be cut in half.

3.5 Noise

Motor noise is divided into N level (general level), R level (first level), S level (excellent level) and E level (low noise level) four levels. R is lower than the level N level 5dB, S level is lower than the level N 10dB, E level lower than the level N 15dB. BONENG general series of motor noise values are lower than the N-class noise level.

- ◆ The noise value of A weighted sound power level measured when the motor is not loaded:

马达功率 (KW)	Motor Power (KW)	同步转速 (r/min) Synchronous speed (r/min)	
		1500/1800	1000/1200
		声功率等级dB (A) Sound power level dB(A)	
0.12		52	/
0.18		52	52
0.25		55	52
0.37		55	54
0.55		58	54
0.75		58	57
1.1		61	57
1.5		61	61
2.2		64	65
3		64	69
4		65	69
5.5		71	69
7.5		71	73
11		75	73
15		75	73
18.5		76	76
22		76	76
30		79	76
37		81	78
45		81	80
55		83	80
75		86	85
90		86	85

◆ 马达负载时测得的A计权声功率级噪声增加值

◆ A weighted sound power level noise increase measured at motor load

马达功率 Motor Power (KW)	同步转速 (r/min) Synchronous speed (r/min)	
	1500/1800	1000/1200
	声功率等级dB (A) Sound power level dB(A)	
≤11	5	7
>11~37	4	6
≥37~90	3	5

3.6 振动

马达振动等级分为N级(常规级)、R级(降低级)和S级(特殊级)。博能马达转子均采用半键进行动平衡,符合IEC60034-14中N级的振动等级。如需要更低振动的场合,我们可以提供R或S级更低振动要求的马达。

3.6 Vibration

Motor vibration levels are divided into N level (conventional level), R level (lower level) and S level (special level). BONENG motor rotors are half-key balancing, in line with N class IEC60034-14 vibration level. For applications requiring lower vibrations, we can offer motors with lower R or S vibration requirements.

振动等级 Vibration level	转速 Speed (r/min)	马达中心高 Frame size		
		56-132	160-225	250-280
N	600-3600	1.8 mm/s	2.8 mm/s	3.5 mm/s
R	600-1800	0.71 mm/s	1.12 mm/s	1.8 mm/s
	>1800-3600	1.12 mm/s	1.8 mm/s	2.8 mm/s
S	600-1800	0.45 mm/s	0.71 mm/s	1.12 mm/s
	>1800-3600	0.71 mm/s	1.12 mm/s	1.8 mm/s

4 电气特性

4.1 电压/频率

IEC 60034-1 将电压和频率的偏差分为A类(电压偏差±5%,频率偏差±2%)和B类(电压偏差±10%,频率偏差+3%/-5%)。马达均能够在A类和B类提供额定转矩。在A类中,温度比正常运行下温度大约提升10K。

标准60034-1 Standard 60034-1	类别 A Class A	类别 B Class B
电压偏差 Voltage deviation	±5%	±10%
频率偏差 Frequency deviation	±2%	+3%/-5%

4 Electrical design

4.1 Voltage/Frequency

IEC 60034-1 classifies voltage and frequency variations into Class A (±5% voltage deviation, ±2% frequency deviation) and class B (±10% voltage deviation, ±3%/-5% frequency deviation). Motors are rated torque for class A and class B. In class A, the temperature is about 10 K higher than during normal operation.

4.2 电气数据公差

- ◆ 效率η
P_N ≤ 150 kW: -0.15 (1 - η)
P_N > 150 kW: -0.10 (1 - η)
效率η为小于1的值
- ◆ 功率因数: (1 - cos φ) / 6
最小绝对值: 0.02
最大绝对值: 0.07
- ◆ 转差率: ±20% (马达的偏差 < 1 kW ± 30% 时是允许的)
- ◆ 堵转电流: +20%
- ◆ 堵转转矩: -15% - +25%
- ◆ 最大转矩: -10%
- ◆ 转动惯量: ±10%

4.3 过载

根据IEC60034标准要求,博能马达能够在额定电压和频率下承受1.5倍的额定电流达2分钟,马达无损坏。

4.4 绝缘系统

博能马达绝缘系统具有可靠性、耐用性好和寿命长、耐冲击能力强的特点。博能马达标准设计温度等级为F(155°C),可选配温度等级为H(180°C)。

4.5 工作制

工作制是马达所承受的一系列负载状况的说明,包括启动、电制动、空载、停机和断能及其持续时间和先后顺序等。工作制分为10类,见下表:

工作制 Duty	含义 Meaning
S1	连续工作制: 恒定负载下运行, 马达达到热稳定状态。 Continuous duty: Constant load operation, the motor reaches the state of thermal stability.
S2	短时运行工作制: 在规定的有限时间内恒载运行, 随后停机直至马达恢复到环境温度。 Short-time duty: constant load for a predetermined limited time, and then stop the motor until it returns to ambient temperature.
S3	断续周期工作制: 启动过程对温升无影响。按一系列相同的工作周期运行。 Intermittent periodic duty: start-up process has no effect on temperature rise. Run in the same series of work cycles.
S4-S10	断续工作制: 启动过程对温升有影响运行由一系列相同周期构成, 每个周期内包括恒载段和空载和断能段。可用负载持续率cdf和每小时起停次数来描述。 Intermittent duty: Start-up process has an impact on temperature rise, operation consists of a series of the same cycle, each cycle includes the dead load section and no-load and energy-cut section. It can use load continuation cdf and start and stop every hour to describe.

4.2 Electrical data tolerances

- ◆ Efficiency η
P_N ≤ 150 kW: -0.15 (1 - η)
P_N > 150 kW: -0.10 (1 - η)
Efficiency η is a value less than one
- ◆ Power factor: (1 - cos φ) / 6
Minimum absolute value: 0.02
Maximum absolute value: 0.07
- ◆ Slip rate: ±20% (When motor power < 1kW, deviation ± 30% is allowed)
- ◆ Locked-rotor motor current: +20%
- ◆ Locked-rotor torque: -15% - +25%
- ◆ Maximum torque: -10%
- ◆ Rotational inertia: ±10%

4.3 Overload

According to standard IEC60034, BONENG motors can withstand 1.5 times the rated current at rated voltage and frequency for 2 minutes without damage.

4.4 Insulation system

BONENG motors insulation system with reliability, durability and long life, impact resistance and strong features. BONENG motors standard design temperature is class F (155 °C), optional temperature class H (180 °C).

4.5 Duty

The duty is a description of some of the column load conditions that the motor is subjected to, including starting, Electric brake, no-load, downtime, power-off, duration and sequencing. Work system is divided into 10 categories, see the table below:

4.6 负载率

负载持续率是负载持续时间与工作周期持续时间的比值。工作周期时间是运行时间总和加上断能间歇时间。Cdf=一周运行时间总和/工作周期时间*100%。我司生产的通用系列马达工作制均为S1,如果S1工作制的马达用于S2或S3工作制下,允许输出功率应是额定功率与功率增长系数K的乘积。增长系数取值见下表:

工作制		Duty	功率增长系数K	Power growth factor K
S2	运行时间 operation hours	60 min	1.1	
		30 min	1.2	
		10 min	1.4	
S3	负载率 (cdf) load factor (cdf)	60%	1.1	
		40%	1.15	
		25%	1.3	
		15%	1.4	
S4-S10	为确定额定功率和工作制,必须给出每小时起停次数和起停方式,负载时间,制动类型,制动时间,空载断能时间等。 In order to determine the rated power and working system, it is necessary to give start and stop numbers per hour, start and stop mode, load time, brake type, braking time and no-load power-off time.		另询	Please consult separately

4.7 防护等级

博能马达防护严格执行IEC60034-5相关标准,我司生产的马达的防护以IP55作为标准配置,根据客户需求我司还可以提供更高防护等级的马达。

4.7 Degree of protection

BONENG motor protection strict implementation of IEC60034-5 related standards, our production of the motor protection is IP55 as a standard configuration, according to customer needs we can also provide a higher degree of protection of the motor.

IP	第一位表征数字	First characteristic numeral	第二位表征数字	Second characteristic numeral
	防异物等级	Protection against solid objects	防水等级	Protection against liquid
0	无专门防护	No special protection	无专门防护	No special protection
1	防止直径大于50mm的固体异物进入壳体	Protected against solid objects greater than 50mm	垂直滴水应无有害影响	Protected against dripping water
2	防止直径大于12mm的固体异物进入壳体	Protected against solid objects greater than 12mm	当马达从正常位置向任何方向倾斜15°以内任一角度时,垂直滴水应无有害影响	Protected against dripping water when tilted up to 15°
3	防止直径大于2.5mm固体异物进入壳体	Protected against solid objects greater than 2.5mm	防止淋水	Protected against spraying water
4	防止直径大于1mm固体异物进入壳体	Protected against solid objects greater than 1mm	防溅水	Protected against splashing water
5	防尘	Dust-protected	防喷水	Protected against water jets
6	尘密	Dust-tight	防强烈喷水	Protected against heavy seas
7	/	/	防短时浸水	Protected against the effects of immersion
8	/	/	防长期潜水	Protected against the effects of continuous submersion

5 可选件

5.1 冷却与通风

博能马达标准冷却方式为自扇冷却，其冷却效能与马达的旋转方向无关（冷却方法符合IEC60034-6标准的IC411）。对于某些应用，可以考虑配置独立风机，如：

- ◆ 马达在低速运行时，推荐使用独立风机，从而使马达得到有效利用。
- ◆ 马达在明显高于额定同步转速的速度运行时，同样推荐选用独立风机，这样有助于降低马达噪声。
- ◆ 冷却方式：
IC410马达表面自然冷却
IC411马达表面自扇冷却
IC416马达表面独立风机强制风冷配独立风机时，须根据需求选择合适的风机参数配置。
- ◆ 独立风机技术参数

机座号 Frame size	型号 Type	电压 (V) Voltage (V)	频率 (Hz) Frequency (Hz)	功率 (W) Power (W)	电流 (A) Current (A)	转速 (r/min) Speed (r/min)
063	G63	400 / 460	50 / 60	24 / 32	0.065 / 0.07	2800 / 3400
071	G71	400 / 460	50 / 60	35 / 36	0.1 / 0.072	2800 / 3300
080	G80	400 / 460	50 / 60	37 / 38	0.1 / 0.08	2700 / 3400
090	G90	400 / 460	50 / 60	45 / 40	0.1 / 0.08	2500 / 3200
100	G100	400 / 460	50 / 60	45 / 70	0.1 / 0.13	2750 / 3250
112	G112	400 / 460	50 / 60	50 / 80	0.1 / 0.13	2750 / 3200
132	G132	400 / 460	50 / 60	40 / 50	0.13 / 0.15	1450 / 1700
160	G160	400 / 460	50 / 60	70 / 100	0.13 / 0.15	1350 / 1550
180	G180	400 / 460	50 / 60	70 / 100	0.13 / 0.15	1350 / 1550
200	G200	400 / 460	50 / 60	180 / 270	0.36 / 0.45	1250 / 1350
225	G225	400 / 460	50 / 60	200 / 280	0.36 / 0.45	1200 / 1300
250	G250	400 / 460	50 / 60	400 / 600	0.9 / 1.0	1300 / 1400
280	G280	400 / 460	50 / 60	450 / 600	0.9 / 1.0	1250 / 1400

5 Options

5.1 Cooling and ventilation

BONENG motors are equipped with a radial cooling fan as standard and their cooling performance is independent of the direction of rotation of the motor (The cooling method is IC411, meets the IEC60034-6 standard). For some applications, you can consider use separate drive fans such as:

- ◆ Motor is running at low speed, separately driven fan is recommended, so that the motor can be used efficiently.
- ◆ When the motor is operated at a speed obviously higher than the rated synchronous speed, it is also recommended to use a separate drive fan, which helps to reduce the motor noise.
- ◆ Cooling method:
IC410 motor surface self-cooling
IC411 motor surface self-fan cooling
IC416 motor surface independent fan forced cooling
With independent drive fan, you must select the appropriate fan parameter configuration according to needs.
- ◆ Independent fan technical parameters

5.2 编码器

博能马达可与编码器实现速度闭环控制，编码器具有分辨率和控制精度高运行可靠的特点。

◆ 编码器电气参数

编码器规格 Encoder type	高性能HTL编码器 High-performance encoder with HTL	经济型HTL编码器 Cost-effective encoder with HTL	高性能TTL编码器 High-performance encoder with TTL
电源电压 Voltage	10-30V	10-30V	5-30V
信号输出形式 Signal output form	推挽 push-pull	推挽 push-pull	RS422
分辨率 Resolution	1024	1024	1024
最大输出频率 Maximum output frequency	300KHz	100KHz	300KHz
工作温度 Working temperature	-20°C~70°C	-10°C~70°C	-20°C~70°C
防护等级 Degree of Protection	IP65	IP55	IP65
输出信号 Output signal	A; A-; B; B-; 0; 0-; 0V; +V; 屏蔽 GND	A; A-; B; B-; Z; Z-; 0V; +V; 屏蔽 GND	A; A-; B; B-; 0; 0-; 0V; +V; 屏蔽 GND

5.2 Encoder

BONENG motor can be connected with the encoder to achieve speed closed-loop control, the encoder has the characteristics of high resolution, high control accuracy and reliable operation.

◆ Encoder electrical parameters

◆ 编码器示意图

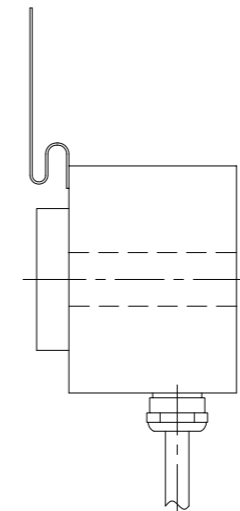

◆ Encoder machine dimension

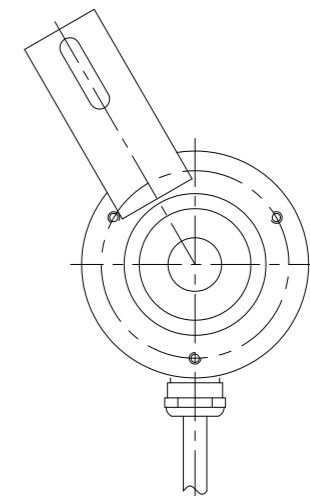

5.3 制动器

根据用户需求博能马达可以在马达后端盖上安装外部制动装置，制动装置是个带有直流线圈励磁的盘式制动器，用直流线圈通电后产生的电磁力作用于弹簧使制动器释放。制动器设计为失电制动，符合基本的安全要求。制动器选择安装手动释放手柄或释放螺钉的方式实现机械释放。由于制动器线圈工作电源为直流，因此每个制动器都配有一个整流装置，该装置用于将外部的单相或两相相应的工频交流电经简单的桥式整流整成制动器线圈工作需求的相应的直流电并供给制动器线圈。制动器是由控制系统控制动作的，这个控制系统可以安装在马达接线盒内也可以安装在配电柜内。制动器结构原理如下：

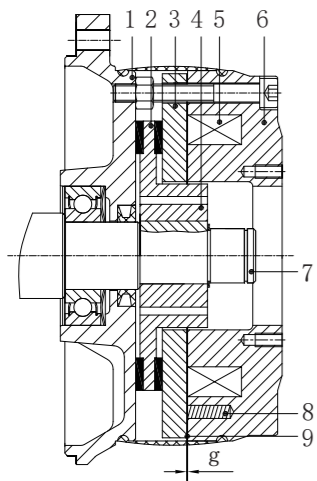

- | | |
|-------------|----------------------------|
| 1、马达后端盖 | 1、Motor back end cover |
| 2、制动器摩擦盘 | 2、Brake friction disk |
| 3、制动器衔铁 | 3、Brake armature disks |
| 4、制动器花键套 | 4、Brake splined hub |
| 5、制动器直流励磁线圈 | 5、Brake DC excitation coil |
| 6、制动器定子 | 6、Brake stator |
| 7、马达转轴 | 7、Motor shaft |
| 8、制动弹簧 | 8、Brake thrust spring |
| 9、制动器工作间隙 | 9、Brake air gap |

◆ 制动器快速制动（预置常开触点）
博能马达的制动器在整流器上配置了一对整流器直流回路的常开触点，通过对常开触点的控制，可实现快速制动，快速制动可用于提升装置或其他需要确保制动器在马达断电后尽可能缩小电气延时实现立即制动的使用场合，快速制动接线图参照第13章“电气连接原理图”。马达制动器的整流器示意图如下：

5.3 Brake

According to user requirements, BONENG motors can installed an external brake device on the motor back end cover, the brake device is a DC coil excitation disc brake, electromagnetic force generated when the DC coil is energized acts on the spring to release the brake. Brakes are designed for loss of power and meet basic safety requirements. Brake can select mounted manual release handle or release screw to achieve mechanical release. Each brake is equipped with a rectifying device because the brake coil works with direct current. The device is used to change the power frequency current (single phase or two phase) provided by the outside through a simple bridge rectifier structure to the direct current to meet the working needs of brake coil, and supply it to the brake coil. Brakes are controlled by a control system that can be installed in the motor terminal box or in a power distribution cabinet. Brake structure principle is as follows:

◆ Braking fast brake (Preset normally open contacts)
Using BONENG universal brake motors for applications such as hoisting gear or other applications that require brakes to minimize brake delay after motor has been powered down for immediate braking, BONENG motor to the brake configuration of the rectifier to provide users with a pair of rectifier DC circuit normally open contact, through the normally open contact of the control, you can easily and quickly achieve the rapid braking you want. Rectifier schematic diagram is as follows:

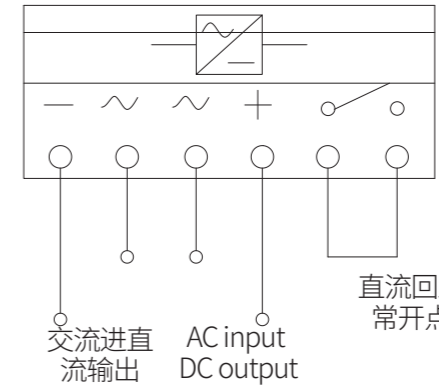

- ◆ 制动器微动开关
制动器微动开关提供一组常开和一组常闭的开关量信号用于检测制动器的工作状态，微动开关通过对制动器工作状态的检测可以反馈一个开关量信号，通过对反馈的开关量信号的处理可以有效的防止制动器在没有释放的情况下马达启动，这样即达到了对制动器工作状态的监控也更有效的保护了马达。
- ◆ 马达选配制动器时，须根据要求选择相应的代号；制动器可提供不同的电压配置以满足用户需求。

直流回路常开点
DC circuit normally open contact

- ◆ Brake micro switch
Brake micro switch provides a group of normally open and a group of normally closed switch signal used to detect the working status of the brake, the micro switch can feed back a switch quantity signal by detecting the working state of the brake, By processing the feedback switch signal, the brake can be effectively prevented from starting without releasing the motor, In this way, the brake working state monitoring and more effective protection of the motor.
- ◆ When the motor is selected for brakes, the corresponding accessory code must be selected according to the requirement; Brakes can provide different voltage configurations to meet user needs.

◆ 制动器参数

◆ Brake parameters

制动器型号	Brake type	BN05	BN06	BN10	BN14	BN16	BN18	BN20	BN25	BN30
制动力矩 (N.m)	Brake torque (N.m)	2	4	16	60	80	150	300	600	1000
制动器功率 (W)	Brake power (W)	13	20	30	50	55	85	100	110	200
额定间隙 (mm)	Rated gap (mm)	0.2	0.2	0.2	0.3	0.3	0.4	0.4	0.5	0.6
最大间隙 (mm)	Maximum gap (mm)	0.5	0.5	0.5	0.75	0.75	1	1	1.25	1.5
交流制动电压 (AC-V)	AC brake voltage (AC-V)	230or400	230or400	230or400	230or400	400	400	400	400	400
直流制动电压 (DC-V)	DC brake voltage (DC-V)	103or180	103or180	103or180	103or180	180	180	180	180	180
适配马达机座号	Fit motor frame size	56-63	71	80-90	100-112	132	160	180	200-225	250-280
制动吸合时间 (ms)	Brake actuation time (ms)	40	40	70	190	200	260	340	390	420
慢速制动释放时间 (ms)	Slow brake releasing time (ms)	300	300	450	570	600	780	1650	2000	3000
快速制动释放时间 (ms)	Rapid brake releasing time (ms)	30	30	45	57	60	78	165	230	380

5.4 马达热保护

马达热保护是指将温度保护传感器或温度检测传感器嵌入马达定子绕组或其他适当的地方,从而使其不会因为过热而受到破坏。温度传感器选择如下:

- ◆ PTC 热敏电阻温度保护

3只PTC热敏电阻以串联的方式将每个电阻分别埋于马达三相绕组端部并从接线盒处引出,用户可根据实际情况将引线连接于变频器相应端子上或相应的热继电器上以实现马达绕组的过热保护。目前,最常用的马达绕组过热保护方式是采用在马达绕组中安装PTC热敏电阻进行保护。由于热敏电阻的热容量较低以及其在绕组间优良的热传导特性,绕组温度可被准确的监控。当达到极限温度时(标称跳闸温度),PTC热敏电阻阻值会出现一个阶跃变化。这一变化被跳闸装置捕捉后,即可断开辅助回路。PTC热敏电阻本身不能耐受大电流和高电压。否则会导致半导体器件损坏。PTC热敏电阻和跳闸装置的开关滞后效应小,因此可以实现快速重起。对于重载起动、起动频率高、负载变化大、环境温度高或电源波动大等应用场合,建议马达使用该类保护。

5.4 Motor thermal protection

Motor thermal protection refers to the temperature protection sensor or temperature detection sensor embedded in the motor stator windings or other appropriate place, so that motor will not be damaged due to overheating. Temperature sensor options are as follows:

- ◆ PTC thermistor temperature protection

Three PTC thermistors are connected in series with each resistor buried in the motor three-phase winding end and leads from the terminal box, the user can according to the actual situation connected them to the frequency converter terminal drive or the thermorelay thermal relay to achieve the motor winding overheating protection. At present, the most commonly used motor winding overheating protection is the use of PTC thermistors installed in the motor windings for protection. The winding temperature can be accurately monitored due to the lower thermal capacity of the thermistor and its excellent thermal conductivity around the foot. When the limit temperature is reached (nominal trip temperature), there is a step change in the PTC thermistor resistance. After this change is captured by the trip device, the auxiliary circuit can be disconnected. PTC thermistor itself can't tolerate high current and high voltage, otherwise it will lead to damage to the semiconductor device. PTC thermistor and trip device switching hysteresis effect is small, so you can achieve rapid restart. For heavy load start, high start frequency, large load changes, high ambient temperature or power fluctuations and other applications, we recommended that the motor use this type of protection.

- ◆ 热敏开关温度保护

3只双金属片开关以串联的方式将每个开关分别埋于马达三相绕组端部并从接线盒处引出,双金属片开关提供开关量信号,用户可根据实际情况将其连接在检测回路中实现马达绕组过热保护。

- ◆ PT100 温度传感器

PT100 温度传感器是一种精确、灵敏度高的传感器,其线性温度阻值优于其他电阻式传感器,性能稳定、可靠性高。

- ◆ 防潮加热保护

当马达处于较为恶劣的环境时,比如湿度非常大或者昼夜温差比较大,马达的绕组很可能出现凝露的现象,这样会带来马达烧毁的风险。对于这种情况,建议对马达绕组配置防潮加热带。马达防潮加热带必须在马达工作过程中处于不工作状态;当马达停机时,防潮加热带必须启动工作,为绕组加热。防潮加热带的电气参数如下表所示。

- ◆ Thermal switch temperature protection

3 bimetal switches in series way to each switch are buried in the motor end of the three-phase winding and leads from the terminal box, bimetal switches provide the switch signal, the user can achieve the motor winding overheating protection based on the actual situation in the detection circuit.

- ◆ PT100 Thermistor Sensor Temperature Protection

PT100 thermistor is a high precision, high sensitivity sensor with better linear temperature resistance than other resistive sensors with stable performance and high reliability.

- ◆ Moisture-proof heating protection

When the motor is in a harsh environment, such as large humidity or relatively large temperature difference between day and night, the motor winding is likely to condensation phenomenon, which will bring the risk of motor burned. In this case, we advisable to configure the motor windings with moisture-proof heating belt. The motor must be in not working state when the Moisture-proof heating belt is in the working process; when the motor is down, moisture-proof heating belt must be started for the winding heating. Electrical parameters of moisture-proof heating belt are shown in the following table.

防潮加热带电气参数

Electrical parameters of moisture-proof heating belt

机座号 Frame size	功率(w) Power (W)	电压(v) Voltage (V)
56-71	10	220
80-90	20	220
100-112	30	220
132-160	40	220
180-200	50	220
225-280	60	220

6 变频应用

博能通用型全封闭自扇冷却三相异步马达适于变转速、恒转速的各种应用。马达带有特定的负载时能够使用变频器驱动,在不同频率下马达能承受的负载转矩如下图表所示:

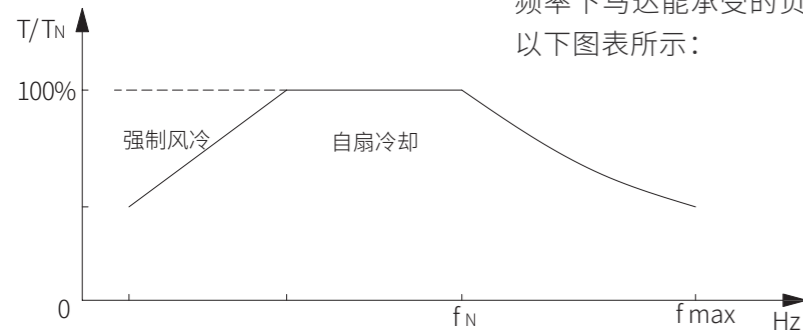

负载转矩在允许的转矩范围内时,马达能够自扇冷却;当负载转矩超过所允许的转矩时,马达需要强迫冷却。在马达运行速度超过额定转速时,噪声和振动值将增加,并且轴承的寿命将缩短。
马达所允许的最大安全转速如下:

机座号 Frame size	4极 4-pole		6极 6-pole	
	最高转速 Maximum speed (r/min)	最大频率 Maximum frequency (Hz)	最高转速 Maximum speed (r/min)	最大频率 Maximum frequency (Hz)
63	3600	120	/	/
71	3600	120	2400	120
80	3600	120	2400	120
90	3600	120	2400	120
100	3600	120	2400	120
112	3600	120	2400	120
132	2700	90	2400	120
160	2700	90	2400	120
180	2700	90	2400	120
200	2250	75	1800	90
225	2250	75	1800	90
250	2250	75	1800	90
280	2250	75	1800	90

6 Frequency conversion applications

BONENG general-purpose fully-enclosed self-fan cooling three-phase asynchronous motors are suitable for variable speed, constant speed. The motor can be driven by the inverter with a specific load. The load torque that the motor can withstand at different frequencies is shown in the figure below:

T: 输出转矩 T: Output torque
TN: 额定转矩 TN: Rated torque
fN: 额定频率 fN: Rated frequency
fmax: 最大频率 fmax: Maximum frequency

When the load torque is within the allowable torque range, the motor can be cooled by the self-fan; when the load torque exceeds the allowable torque, the motor needs to be forced to cool. When the motor speed exceeds the rated speed, the noise and vibration values will increase and the bearing life will be shortened.
The maximum safe speed allowed of the motor is as follows:

7 MP/MU马达型号表示方法

MP132M4B55 HC 3-A 0 N 0 0-1 1 1

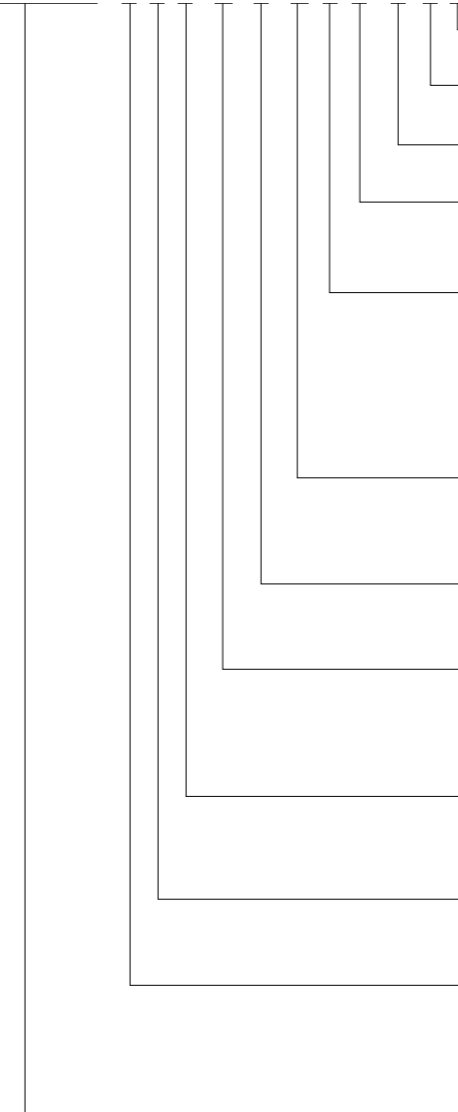

进线孔位置

1/2/3/4

接线盒位置

1/2/3/4

安装方位

1/2/3/4/5/6

防护等级

0=标准配置(IP55/F) 1=带防雨罩 J=带金属接头 K=带金属接头和防雨罩
4=IP65/金属接头 5=IP65/金属接头和带防雨罩

热保护和加热保护

0=无绕组保护 1=热敏电阻 2=热敏开关 3=温度传感器PT100
4=加热带 5=热敏电阻和加热带 6=热敏开关和加热带
7=温度传感器PT100和加热带

制动器	制动器
N=无制动器 A=220-240VAC制动器 D=220-240VAC制动器带手柄 B=380-415VAC制动器 E=380-415VAC制动器带手柄 R=220-240VAC双制动器带手柄 S=380-415VAC双制动器带手柄	N=无制动器 B=380-415VAC制动器 E=380-415VAC制动器带手柄 S=380-415VAC双制动器带手柄

编码器

0=无编码器 3=经济型HTL编码器(1024P) 4=高性能TTL编码器(1024P)
1=高性能HTL编码器(1024P) 2=标配编码器附件

冷却方式

A=自扇冷却 F=强冷风机(配编码器必选,其他不建议)

频率/电压	频率/电压
1=50Hz 220V△/380VY 2=50Hz 230V△/400VY 7=60Hz 440VY 8=60Hz 460VY A=50Hz 240V△/415VY C=60Hz 480VY E=60Hz 220V△/380VY	3=50Hz 380V△/660VY 4=50Hz 400V△/690VY 5=60Hz 440V△ 6=60Hz 460V△ B=50Hz 415V△ D=60Hz 480V△ F=60Hz 380V△

机座材质

L=铝机座(≤100机座) C=铸铁机座

安装形式	安装形式
H=B3底脚安装 F=B5法兰安装 S=B14B法兰安装	H=B3底脚安装 F=B5法兰安装 S=B14B法兰安装(≤132机座)

功率(kW)	MP=IE3三相交流异步马达 MU=IE4三相交流异步马达		功率(kW)	MP=IE3三相交流异步马达 MU=IE4三相交流异步马达	
	4极	6极		4极	6极
0.12	MP063M4A12... MU063M4A12...	/	4	MP112L4B40... MU132S4B40...	MP132M6B40... MU132M6B40...
0.18	MP063M4A18... MU063M4A18...	MP071M6A18... MU071M6A18...	5.5	MP132M4B55... MU132M4B55...	MP132L6B55... MU160M6B55...
0.25	MP071M4A25... MU071M4A25...	MP071M6A25... MU080M6A25...	7.5	MP132L4B75... MU160M4B75...	MP160S6B75... MU160L6B75...
0.37	MP071M4A37... MU080M4A37...	MP080M6A37... MU080M6A37...	11	MP160M4C11... MU160L4C11...	MP160M6C11... MU180L6C11...
0.55	MP080M4A55... MU080M4A55...	MP080M6A55... MU090M6A55...	15	MP160L4C15... MU180M4C15...	MP180M6C15... MU200L6C15...
0.75	MP080M4A75... MU090S4A75...	MP090S6A75... MU090L6A75...	18.5	MP180M4C18... MU180L4C18...	MP200M6C18... MU200L6C18...
1.1	MP090S4B11... MU090L4B11...	MP090M6B11... MU100L6B11...	22	MP180L4C22... MU200L4C22...	MP200M6C22... MU225M6C22...
1.5	MP090M4B15... MU100L4B15...	MP100M6B15... MU122M6B15...	30	MP200M4C30... MU225S4C30...	MP225M6C30... MU250M6C30...
2.2	MP100M4B22... MU100L4B22...	MP112M6B22... MU132S6B22...	37	MP225M4C37... MU225M4C37...	MP250M6C37... MU280S6C37...
3	MP100M4B30... MU112M4B30...	MP132S6B30... MU132M6B30...	45	MP225M4C45... MU250M4C45...	MP280S6C45... MU280M6C45...
/	/	/	55	MP250M4C55... MU280S4C55...	MP280M6C55... MU280M6C55...
/	/	/	75	MP280S4C75... MU280M4C75...	/
/	/	/	90	MP280M4C90... MU280M4C90...	/

7 MP/MU motor type Designation

MP132M4B55 HC3-A0N00-111

Cable entry location

1/2/3/4

Terminal box location

1/2/3/4

Mounting position

1/2/3/4/5/6

Degree of protection

0= standard configuration (IP55/F) 1= with rain cover J=with metal joint K= with metal joint and rain cover
4= IP65/with metal joint 5= IP65/with metal joint and rain cover

Thermal protection and heating protection

0= no winding protection 1= thermistor 2= thermoswitch 3= PT100 temperature sensor
4= heating belt 5= thermistor and heating belt 6= thermoswitch and heating belt
7= PT100 temperature sensor and heating belt

Brake	N=no brake A=220-240VAC brake D=220-240VAC brake with handle B=380-415VAC brake E=380-415VAC brake with handle R=220-240VAC double brake with handle S=380-415VAC double brake with handle	Brake	N=no brake B=380-415VAC brake E=380-415VAC brake with handle S=380-415VAC double brake with handle
-------	--	-------	---

Encoder

0= no encoder 3= economic HTL encoder (1024P) 4= high-performance TTL encoder(1024P)
1= high-performance HTL encoder (1024P) 2= standard encoder accessories

Cooling method

A=self-fan cooling F=forced-fan cooling(it must be chosen with encoder,otherwise,it is not advised to choose)

Frequency/voltage	1=50Hz 220V△/380VY 2=50Hz 230V△/400VY 7=60Hz 440VY 8=60Hz 460VY A=50Hz 240V△/415VY C=60Hz 480VY E=60Hz 220V△/380VY	Frequency/voltage	3=50Hz 380V△/660VY 4=50Hz 400V△/690VY 5=60Hz 440V△ 6=60Hz 460V△ B=50Hz 415V△ D=60Hz 480V△ F=60Hz 380V△
-------------------	--	-------------------	--

Frame material

L=cast-aluminum(frame size≤100) C=cast-iron frame

Type of construction	H=B3 foot-mounted F=B5 flange-mounted S=B14B flange-mounted	Type of construction	H=B3 foot-mounted F=B5 flange-mounted S=B14B flange-mounted (frame size≤132)
----------------------	---	----------------------	--

Power(kW)	MP=IE3 three-phase asynchronous motor MU=IE4 three-phase asynchronous motor		Power(kW)	MP=IE3 three-phase asynchronous motor MU=IE4 three-phase asynchronous motor	
	4 Poles	6 Poles		4 Poles	6 Poles
0.12	MP063M4A12... MU063M4A12...	/	4	MP112L4B40... MU132S4B40...	MP132M6B40... MU132M6B40...
0.18	MP063M4A18... MU063M4A18...	MH071M6A18... MP071M6A18... MU071M6A18...	5.5	MP132M4B55... MU132M4B55...	MP132L6B55... MU160M6B55...
0.25	MP071M4A25... MU071M4A25...	MP071M6A25... MU080M6A25...	7.5	MP132L4B75... MU160M4B75...	MP160S6B75... MU160L6B75...
0.37	MP071M4A37... MU080M4A37...	MP080M6A37... MU080M6A37...	11	MP160M4C11... MU160L4C11...	MP160M6C11... MU180L6C11...
0.55	MP080M4A55... MU080M4A55...	MP080M6A55... MU090M6A55...	15	MP160L4C15... MU180M4C15...	MP180M6C15... MU200L6C15...
0.75	MP080M4A75... MU090S4A75...	MP090S6A75... MU090L6A75...	18.5	MP180M4C18... MU180L4C18...	MP200M6C18... MU200L6C18...
1.1	MP090S4B11... MU090L4B11...	MP090M6B11... MU100L6B11...	22	MP180L4C22... MU200L4C22...	MP200M6C22... MU225M6C22...
1.5	MP090M4B15... MU100L4B15...	MP100M6B15... MU112M6B15...	30	MP200M4C30... MU225S4C30...	MP225M6C30... MU250M6C30...
2.2	MP100M4B22... MU100L4B22...	MP112M6B22... MU132S6B22...	37	MP225M4C37... MU225M4C37...	MP250M6C37... MU280S6C37...
3	MP100M4B30... MU112M4B30...	MP132S6B30... MU132M6B30...	45	MP225M4C45... MU250M4C45...	MP280S6C45... MU280M6C45...
/	/	/	55	MP250M4C55... MU280S4C55...	MP280M6C55... MU280M6C55...
/	/	/	75	MP280S4C75... MU280M4C75...	/
/	/	/	90	MP280M4C90... MU280M4C90...	/

马达安装方位:

Motor mounting position:

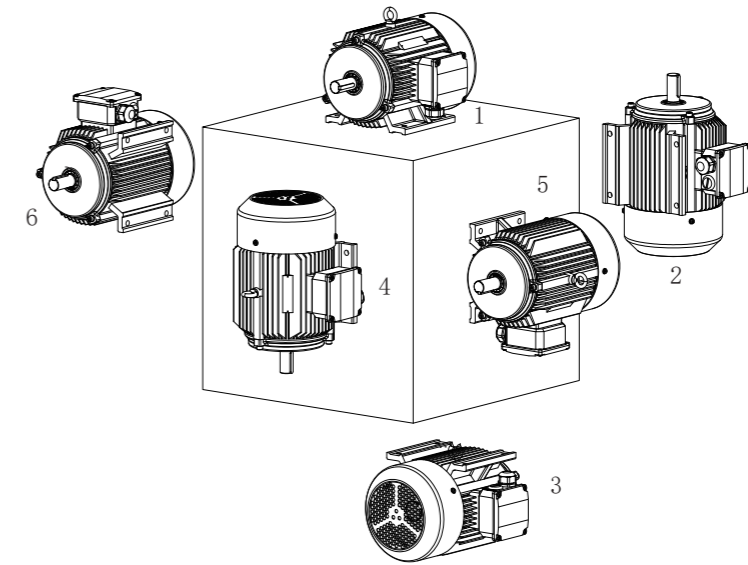

马达接线盒和进线孔位置(视角: 马达尾部)

Motor terminal box and cable entry location (View Angle: motor tail):

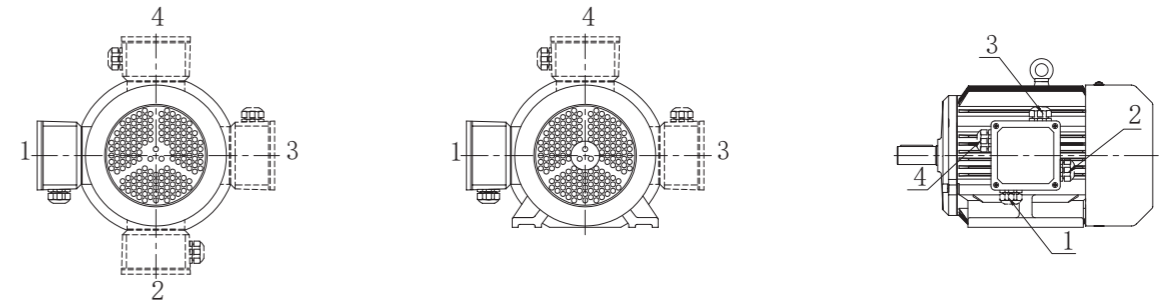

马达标配颜色

(RAL5015)

Standard color of motor

(RAL5015)

8 MP马达选型
技术参数 (IE3能效)

8 MP motor selection
technical data (efficiency IE3)

50Hz 380V 4P-1500r/min S1

机座号	额定功率 (kW)	额定电压 (V)	额定频率 (Hz)	接法	额定转速 (r/min)	额定转矩 (N.m)	能效等级	效率 (%)	功率因数 (COS φ)	额定电流 (A)	启动转矩倍数	最大转矩倍数	启动电流倍数	空载噪声 (dB)	转动惯量 (kg.m ²)
Frame size	P _N (kW)	U _N (V)	F _N (Hz)	Conn.	n _N (r/min)	T _N (N.m)	IE-CL	η (%)	COS φ	I _N (A)	T _{st} /T _N	T _{max} /T _N	I _{st} /I _N	LWdB (A)	J (kg.m ²)
056M	0.09	220/380	50	△/Y	1330	0.65	-	59.1	0.73	0.55/0.35	2.1	2.4	3.1	53	0.0003
063M	0.12	220/380	50	△/Y	1325	0.9	IE3	64.8	0.73	0.7/0.4	2.1	2.4	3.1	53	0.00034
063M	0.18	220/380	50	△/Y	1340	1.3	IE3	69.9	0.73	0.95/0.55	2.2	2.5	3.4	53	0.00051
071M	0.25	220/380	50	△/Y	1365	1.7	IE3	73.5	0.74	1.3/0.75	2.5	2.6	3.9	53	0.00074
071M	0.37	220/380	50	△/Y	1375	2.6	IE3	77.3	0.75	1.7/1.0	2.7	2.7	4.2	53	0.00099
080M	0.55	220/380	50	△/Y	1420	3.7	IE3	80.8	0.76	2.4/1.4	2.5	2.7	5.3	56	0.0019
080M	0.75	220/380	50	△/Y	1420	5.0	IE3	82.5	0.78	3.1/1.8	2.4	2.5	5.3	56	0.00249
090S	1.1	220/380	50	△/Y	1425	7.4	IE3	84.1	0.78	4.4/2.6	2.5	2.5	5.9	59	0.00351
090M	1.5	220/380	50	△/Y	1425	10.1	IE3	85.3	0.78	5.8/3.5	2.7	2.5	6.2	59	0.00442
100M	2.2	220/380	50	△/Y	1450	14.5	IE3	86.7	0.82	8.3/4.8	2.6	3.0	6.8	64	0.00926
100M	3	220/380	50	△/Y	1450	19.8	IE3	87.7	0.82	11/6.5	2.8	3.0	7.1	64	0.0113
112L	4	380/660	50	△/Y	1450	26.3	IE3	88.6	0.82	8.4/4.9	2.1	2.6	6.2	65	0.0143
132M	5.5	380/660	50	△/Y	1460	36.0	IE3	89.6	0.84	11.5/6.6	2.0	2.5	6.7	71	0.0307
132L	7.5	380/660	50	△/Y	1460	49.1	IE3	90.4	0.85	15/8.7	2.0	2.4	6.6	71	0.0382
160M	11	380/660	50	△/Y	1470	71.5	IE3	91.4	0.84	21.8/12.6	2.2	3.1	7.0	73	0.095
160L	15	380/660	50	△/Y	1470	97.4	IE3	92.1	0.85	29.5/17	2.3	3.1	7.0	73	0.12
180M	18.5	380/660	50	△/Y	1475	119.8	IE3	92.6	0.86	35.5/20.5	2.1	3.0	7.1	76	0.169
180L	22	380/660	50	△/Y	1475	142.4	IE3	93	0.86	42/24.5	2.3	3.0	7.3	76	0.195
200M	30	380/660	50	△/Y	1475	194.2	IE3	93.6	0.85	58/33.5	2.4	2.7	6.2	76	0.317
225M	37	380/660	50	△/Y	1480	238.8	IE3	93.9	0.86	70/40.5	2.5	2.7	6.9	78	0.555
225M	45	380/660	50	△/Y	1480	290.4	IE3	94.2	0.86	85/49	2.4	2.5	6.5	78	0.621
250M	55	380/660	50	△/Y	1485	353.7	IE3	94.6	0.86	103/60	2.4	2.7	6.8	79	0.839
280S	75	380/660	50	△/Y	1490	480.7	IE3	95	0.87	139/80	2.4	2.7	6.4	80	1.592
280M	90	380/660	50	△/Y	1490	576.8	IE3	95.2	0.87	166/96	2.5	2.8	6.7	80	1.887

50Hz 380V 6P-1000r/min S1

机座号	额定功率 (kW)	额定电压 (V)	额定频率 (Hz)	接法	额定转速 (r/min)	额定转矩 (N.m)	能效等级	效率 (%)	功率因数 (COS φ)	额定电流 (A)	启动转矩倍数	最大转矩倍数	启动电流倍数	空载噪声 (dB)	转动惯量 (kg.m ²)
Frame size	P _N (kW)	U _N (V)	F _N (Hz)	Conn.	n _N (r/min)	T _N (N.m)	IE-CL	η (%)	COS φ	I _N (A)	T _{st} /T _N	T _{max} /T _N	I _{st} /I _N	LWdB (A)	J (kg.m ²)
071M	0.18	220/380	50	△/Y	880	2.0	IE3	63.9	0.68	1.1/0.65	2.1	2.4	2.8	51	0.00115
071M	0.25	220/380	50	△/Y	880	2.7	IE3	68.8	0.7	1.4/0.8	2.1	2.3	2.9	51	0.0013
080M	0.37	220/380	50	△/Y	935	3.8	IE3	73.5	0.73	1.9/1.1	2.0	2.4	4.0	54	0.00227
080M	0.55	220/380	50	△/Y	935	5.6	IE3	77.2	0.74	2.6/1.5	2.0	2.4	4.1	54	0.0032
090S	0.75	220/380	50	△/Y	940	7.6	IE3	78.9	0.73	3.4/2.0	1.9	2.4	4.1	57	0.00418
090M	1.1	220/380	50	△/Y	945	11.1	IE3	81	0.74	4.9/2.8	3.0	2.3	4.3	57	0.00599
100M	1.5	220/380	50	△/Y	950	15.1	IE3	82.5	0.74	6.5/3.8	2.4	2.5	5.1	61	0.0117
112M	2.2	220/380	50	△/Y	955	22.0	IE3	84.3	0.76	9.1/5.3	2.2	2.3	5.2	65	0.0171
132S	3	220/380	50	△/Y	965	29.7	IE3	85.6	0.76	12.2/7.1	2.2	2.4	5.9	69	0.0332
132M	4	380/660	50	△/Y	970	39.4	IE3	86.8	0.77	9.1/5.3	2.3	2.4	6.2	69	0.043
132L	5.5	380/660	50	△/Y	970	54.1	IE3	88	0.78	12.2/7.1	2.2	2.2	6.2	69	0.0571
160S	7.5	380/660	50	△/Y	970	73.8	IE3	89.1	0.8	16/9.3	1.9	2.7	5.3	73	0.104
160M	11	380/660	50	△/Y	970	108.3	IE3	90.3	0.8	23.2/13.4	2.1	2.7	5.6	73	0.146
180M	15	380/660	50	△/Y	980	146.2	IE3	91.2	0.82	30.5/17.7	2.2	2.8	7.0	73	0.232
200M	18.5	380/660	50	△/Y	980	180.3	IE3	91.7	0.81	38/22	2.0	2.5	5.7	73	0.374
200M	22	380/660	50	△/Y	980	214.4	IE3	92.2	0.81	45/26	2.0	2.4	5.6	73	0.417
225M	30	380/660	50	△/Y	985	290.9	IE3	92.9	0.82	60/35	2.2	2.4	6.1	74	0.625
250M	37	380/660	50	△/Y	985	358.7	IE3	93.3	0.84	72/42	2.3	2.7	6.0	76	1.063
280S	45	380/660	50	△/Y	990	434.1	IE3	93.7	0.84	87/50.5	2.2	2.7	6.3	78	1.675
280M	55	380/660	50	△/Y	990	530.6	IE3	94.1	0.85	105/61	2.2	2.6	6.3	78	2.02

50Hz 400V 4P-1500r/min S1

机座号	额定功率 (kW)	额定电压 (V)	额定频率 (Hz)	接法	额定转速 (r/min)	额定转矩 (N.m)	能效等级	效率 (%)	功率因数 (COS φ)	额定电流 (A)	启动转矩倍数	最大转矩倍数	启动电流倍数	空载噪声 (dB)	转动惯量 (kg.m ²)
Frame size	P _N (kW)	U _N (V)	F _N (Hz)	Conn.	n _N (r/min)	T _N (N.m)	IE-CL	η (%)	COS φ	I _N (A)	T _{st} /T _N	T _{max} /T _N	I _{st} /I _N	LWdB (A)	J (kg.m ²)
056M	0.09	230/400	50	△/Y	1345	0.65	-	59.1	0.7	0.55/0.35	2.3	2.7	3.3	53	0.0003
063M	0.12	230/400	50	△/Y	1345	0.9	IE3	64.8	0.69	0.7/0.4	2.3	2.6	3.3	53	0.00034
063M	0.18	230/400	50	△/Y	1360	1.3	IE3	69.9	0.71	0.95/0.55	2.5	2.8	3.6	53	0.00051
071M	0.25	230/400	50	△/Y	1380	1.7	IE3	73.5	0.71	1.2/0.7	2.9	3.0	4.3	53	0.00074
071M	0.37	230/400	50	△/Y	1385	2.6	IE3	77.3	0.72	1.7/1.0	3.2	3.0	4.6	53	0.00099
080M	0.55	230/400	50	△/Y	1430	3.7	IE3	80.8	0.73	2.4/1.4	3.0	3.0	5.8	56	0.0019
080M	0.75	230/400	50	△/Y	1430	5.0	IE3	82.5	0.75	3.1/1.8	3.0	2.8	5.9	56	0.00249
090S	1.1	230/400	50	△/Y	1435	7.3	IE3	84.1	0.76	4.3/2.5	3.1	2.8	6.6	59	0.00351
090M	1.5	230/400	50	△/Y	1435	10.0	IE3	85.3	0.77	5.8/3.3	3.3	2.8	7.0	59	0.00442
100M	2.2	230/400	50	△/Y	1455	14.4	IE3	86.7	0.79	8.1/4.7	3.0	3.4	7.5	64	0.00926
100M	3	230/400	50	△/Y	1455	19.7	IE3	87.7	0.79	10.9/6.3	3.3	3.4	7.8	64	0.0113
112L	4	400/690	50	△/Y	1455	26.3	IE3	88.6	0.81	8.2/4.7	2.6	2.9	7.1	65	0.0143
132M	5.5	400/690	50	△/Y	1465	35.9	IE3	89.6	0.82	11/6.4	2.5	2.9	7.7	71	0.0307
132L	7.5	400/690	50	△/Y	1465	48.9	IE3	90.4	0.83	14.6/8.5	2.5	2.8	7.7	71	0.0382
160M	11	400/690	50	△/Y	1475	71.2	IE3	91.4	0.82	21.5/12.3	2.6	3.6	7.8	73	0.095
160L	15	400/690	50	△/Y	1475	97.1	IE3	92.1	0.83	28.5/16.5	2.6	3.5	7.8	73	0.12
180M	18.5	400/690	50	△/Y	1475	119.8	IE3	92.6	0.84	34.5/20	2.5	3.4	7.9	76	0.169
180L	22	400/690	50	△/Y	1475	142.4	IE3	93	0.84	41/23.5	2.7	3.5	8.2	76	0.195
200M	30	400/690	50	△/Y	1475	194.2	IE3	93.6	0.84	55.5/32	2.8	3.1	6.9	76	0.317
225M	37	400/690	50	△/Y	1485	237.9	IE3	93.9	0.85	67.5/39	2.9	3.1	7.7	78	0.555
225M	45	400/690	50	△/Y	1485	289.4	IE3	94.2	0.85	81.5/47	2.8	2.9	7.4	78	0.621
250M	55	400/690	50	△/Y	1485	353.7	IE3	94.6	0.85	99.5/57.5	2.8	3.1	7.7	79	0.839
280S	75	400/690	50	△/Y	1490	480.7	IE3	95	0.86	134/77	2.8	3.0	7.2	80	1.592
280M	90	400/690	50	△/Y	1490	576.8	IE3	95.2	0.86	160/92	3.0	3.1	7.5	80	1.887

50Hz 400V 6P-1000r/min S1

机座号	额定功率 (kW)	额定电压 (V)	额定频率 (Hz)	接法	额定转速 (r/min)	额定转矩 (N.m)	能效等级	效率 (%)	功率因数 (COS φ)	额定电流 (A)	启动转矩倍数	最大转矩倍数	启动电流倍数	空载噪声 (dB)	转动惯量 (kg.m ²)
Frame size	P _N (kW)	U _N (V)	F _N (Hz)	Conn.	n _N (r/min)	T _N (N.m)	IE-CL	η (%)	COS φ	I _N (A)	T _{st} /T _N	T _{max} /T _N	I _{st} /I _N	LWdB (A)	J (kg.m ²)
071M	0.18	230/400	50	△/Y	890	1.9	IE3	63.9	0.65	1.1/0.65	2.4	2.7	3.0	51	0.00115
071M	0.25	230/400	50	△/Y	890	2.7	IE3	68.8	0.66	1.4/0.8	2.4	2.6	3.1	51	0.0013
080M	0.														

MP马达选型
技术参数 (续)

MP motor selection
technical data(continue)

60Hz 440V 4P-1800r/min S1

机座号	额定功率(kW)	额定电压(V)	额定频率(Hz)	接法	额定转速(r/min)	额定转矩(N.m)	能效等级	效率(%)	功率因数(COSφ)	额定电流(A)	启动转矩倍数	最大转矩倍数	启动电流倍数	空载噪声(dB)	转动惯量(kg.m ²)
Frame size	P _N (kW)	U _N (V)	F _N (Hz)	Conn.	n _N (r/min)	T _N (N.m)	IE-CL	η (%)	COSΦ	I _N (A)	T _{st} /T _N	T _{max} /T _N	I _{st} /I _N	LWdB(A)	J(kg.m ²)
056M	0.09	440	60	Y	1665	0.5	-	64	0.67	0.3	2.6	3.2	3.9	53	0.0003
063M	0.12	440	60	Y	1665	0.7	IE3	66	0.66	0.4	2.6	3.1	3.9	53	0.00034
063M	0.18	440	60	Y	1675	1.0	IE3	69.5	0.68	0.5	2.8	3.2	4.2	53	0.00051
071M	0.25	440	60	Y	1690	1.4	IE3	73.4	0.7	0.65	3.0	3.3	4.9	53	0.00074
071M	0.37	440	60	Y	1695	2.1	IE3	78.2	0.71	0.9	3.2	3.3	5.3	53	0.00099
080M	0.55	440	60	Y	1735	3.0	IE3	82.5	0.73	1.3	2.9	3.2	6.4	56	0.0019
080M	0.75	440	60	Y	1730	4.1	IE3	85.5	0.75	1.6	2.7	3.0	6.4	56	0.00249
090S	1.1	440	60	Y	1740	6.0	IE3	86.5	0.76	2.3	2.8	2.9	7.1	59	0.00351
090M	1.5	440	60	Y	1740	8.2	IE3	86.5	0.77	3.1	3.0	2.9	7.4	59	0.00442
100M	2.2	440	60	Y	1755	12.0	IE3	89.5	0.8	4.2	2.8	3.4	8.0	64	0.00926
100M	3	440	60	Y	1755	16.3	IE3	89.5	0.8	5.6	3.0	3.4	8.3	64	0.0113
112L	4	440	60	△	1755	21.8	IE3	89.5	0.82	7.3	2.2	2.9	7.1	65	0.0143
132M	5.5	440	60	△	1765	29.8	IE3	91.7	0.83	9.6	2.1	2.8	7.6	71	0.0307
132L	7.5	440	60	△	1765	40.6	IE3	91.7	0.84	13	2.1	2.7	7.5	71	0.0382
160M	11	440	60	△	1775	59.2	IE3	92.4	0.83	19	2.3	3.6	7.9	73	0.095
160L	15	440	60	△	1775	80.7	IE3	93	0.83	25.6	2.4	3.5	8.0	73	0.12
180M	18.5	440	60	△	1775	99.5	IE3	93.6	0.85	31	2.5	3.6	8.6	76	0.169
180L	22	440	60	△	1775	118.4	IE3	93.6	0.85	36.5	2.5	3.6	8.5	76	0.195
200M	30	440	60	△	1780	161.0	IE3	94.1	0.85	49.5	2.7	3.1	7.1	76	0.317
225M	37	440	60	△	1785	198.0	IE3	94.5	0.86	60.5	2.7	3.1	7.9	78	0.555
225M	45	440	60	△	1785	240.8	IE3	95	0.86	73	2.6	2.9	7.5	78	0.621
250M	55	440	60	△	1785	294.3	IE3	95.4	0.86	88.5	2.5	3.1	7.8	79	0.839
280S	75	440	60	△	1790	400.1	IE3	95.4	0.86	120	2.6	3.0	7.4	80	1.592
280M	90	440	60	△	1790	480.2	IE3	95.4	0.86	144	2.8	3.1	7.7	80	1.887

60Hz 440V 6P-1200r/min S1

机座号	额定功率(kW)	额定电压(V)	额定频率(Hz)	接法	额定转速(r/min)	额定转矩(N.m)	能效等级	效率(%)	功率因数(COSφ)	额定电流(A)	启动转矩倍数	最大转矩倍数	启动电流倍数	空载噪声(dB)	转动惯量(kg.m ²)
Frame size	P _N (kW)	U _N (V)	F _N (Hz)	Conn.	n _N (r/min)	T _N (N.m)	IE-CL	η (%)	COSΦ	I _N (A)	T _{st} /T _N	T _{max} /T _N	I _{st} /I _N	LWdB(A)	J(kg.m ²)
071M	0.18	440	60	Y	1105	1.6	IE3	67.5	0.62	0.6	2.6	3.1	3.5	51	0.00115
071M	0.25	440	60	Y	1105	2.2	IE3	71.4	0.64	0.75	2.5	3.0	3.5	51	0.0013
080M	0.37	440	60	Y	1145	3.1	IE3	75.3	0.68	1	2.4	3.0	4.8	54	0.00227
080M	0.55	440	60	Y	1145	4.6	IE3	81.7	0.7	1.3	2.3	2.9	5.0	54	0.0032
090S	0.75	440	60	Y	1150	6.2	IE3	82.5	0.7	1.8	2.2	2.8	4.9	57	0.00418
090M	1.1	440	60	Y	1150	9.1	IE1	83	0.71	2.6	2.2	2.8	5.1	57	0.00599
100M	1.5	440	60	Y	1160	12.3	IE1	84.5	0.71	3.4	2.7	3.0	6.0	61	0.0117
112M	2.2	440	60	Y	1165	18.0	IE2	87.5	0.73	4.7	2.3	2.7	6.0	65	0.0171
132S	3	440	60	Y	1175	24.4	IE2	87.5	0.73	6.2	2.4	2.7	6.9	69	0.0332
132M	4	440	60	△	1175	32.5	IE2	87.5	0.74	8.1	2.5	2.7	7.2	69	0.043
132L	5.5	440	60	△	1175	44.7	IE2	89.5	0.75	11	2.4	2.6	7.1	69	0.0571
160S	7.5	440	60	△	1175	61.0	IE3	91	0.78	13.9	2.1	3.1	6.0	73	0.104
160M	11	440	60	△	1175	89.4	IE3	91.7	0.78	20.5	2.3	3.1	6.3	73	0.146
180M	15	440	60	△	1185	120.9	IE3	91.7	0.81	27	2.4	3.1	8.1	73	0.232
200M	18.5	440	60	△	1185	149.1	IE3	93	0.8	33	2.3	2.9	6.5	73	0.374
200M	22	440	60	△	1185	177.3	IE3	93	0.8	39	2.3	2.8	6.4	73	0.417
225M	30	440	60	△	1185	241.8	IE3	94.1	0.82	51.5	2.4	2.6	7.0	74	0.625
250M	37	440	60	△	1185	298.2	IE3	94.1	0.83	62.5	2.5	3.1	7.0	76	1.063
280S	45	440	60	△	1190	361.1	IE3	94.5	0.83	75.5	2.4	3.0	7.3	78	1.675
280M	55	440	60	△	1190	441.4	IE3	94.5	0.84	91	2.5	2.9	7.3	78	2.02

60Hz 460V 4P-1800r/min S1

机座号	额定功率(kW)	额定电压(V)	额定频率(Hz)	接法	额定转速(r/min)	额定转矩(N.m)	能效等级	效率(%)	功率因数(COSφ)	额定电流(A)	启动转矩倍数	最大转矩倍数	启动电流倍数	空载噪声(dB)	转动惯量(kg.m ²)
Frame size	P _N (kW)	U _N (V)	F _N (Hz)	Conn.	n _N (r/min)	T _N (N.m)	IE-CL	η (%)	COSΦ	I _N (A)	T _{st} /T _N	T _{max} /T _N	I _{st} /I _N	LWdB(A)	J(kg.m ²)
056M	0.09	460	60	Y	1675	0.5	-	64	0.64	0.3	2.8	3.5	4	53	0.0003
063M	0.12	460	60	Y	1675	0.7	IE3	66	0.63	0.4	2.9	3.4	4.0	53	0.00034
063M	0.18	460	60	Y	1680	1.0	IE3	69.5	0.65	0.5	3.0	3.5	4.4	53	0.00051
071M	0.25	460	60	Y	1700	1.4	IE3	73.4	0.67	0.65	3.4	3.6	5.2	53	0.00074
071M	0.37	460	60	Y	1705	2.1	IE3	78.2	0.68	0.9	3.7	3.6	5.6	53	0.00099
080M	0.55	460	60	Y	1740	3.0	IE3	82.5	0.7	1.3	3.4	3.6	7.0	56	0.0019
080M	0.75	460	60	Y	1740	4.1	IE3	85.5	0.73	1.6	3.2	3.3	7.0	56	0.00249
090S	1.1	460	60	Y	1745	6.0	IE3	86.5	0.74	2.3	3.3	3.2	7.5	59	0.00351
090M	1.5	460	60	Y	1745	8.2	IE3	86.5	0.74	3	3.6	3.2	7.8	59	0.00442
100M	2.2	460	60	Y	1760	11.9	IE3	89.5	0.77	4.2	3.2	3.8	8.7	64	0.00926
100M	3	460	60	Y	1760	16.3	IE3	89.5	0.77	5.6	3.5	3.8	9.1	64	0.0113
112L	4	460	60	△	1760	21.7	IE3	89.5	0.8	7.3	2.6	3.3	8.0	65	0.0143
132M	5.5	460	60	△	1770	29.7	IE3	91.7	0.81	9.4	2.5	3.2	8.6	71	0.0307
132L	7.5	460	60	△	1770	40.5	IE3	91.7	0.82	12.7	2.5	3.0	8.6	71	0.0382
160M	11	460	60	△	1775	59.2	IE3	92.4	0.82	18.5	2.7	4.0	8.7	73	0.095
160L	15	460	60	△	1775	80.7	IE3	93	0.82	25	2.8	3.9	8.7	73	0.12
180M	18.5	460	60	△	1780	99.3	IE3	93.6	0.83	30	2.7	3.8	8.9	76	0.169
180L	22	460	60	△	1780	118.0	IE3	93.6	0.83	36	2.8	3.9	9.2	76	0.195
200M	30	460	60	△	1780	161.0	IE3	94.1	0.83	48.5	3.1	3.4	7.8	76	0.317
225M	37	460	60	△	1785	198.0	IE3	94.5	0.84	59	3.1	3.4	8.8	78	0.555
225M	45	460	60	△	1785	240.8	IE3	95	0.85	70.5	3.0	3.2	8.4	78	0.621
250M	55	460	60	△	1785	294.3	IE3	95.4	0.84	86.5	3.0	3.4	8.7	79	0.839
280S	75	460	60	△	1790	400.1	IE3	95.4	0.85	117	3.0	3.3	8.2	80	1.592
280M	90	460	60	△	1790	480.2	IE3	95.4	0.85	140	3.2	3.4	8.5	80	1.887

60Hz 460V 6P-1200r/min S1

机座号	额定功率(kW)	额定电压(V)	额定频率(Hz)	接法	额定转速(r/min)	额定转矩(N.m)	能效等级	效率(%)	功率因数(COSφ)	额定电流(A)	启动转矩倍数	最大转矩倍数	启动电流倍数	空载噪声(dB)	转动惯量(kg.m ²)
Frame size	P _N (kW)	U _N (V)	F _N (Hz)	Conn.	n _N (r/min)	T _N (N.m)	IE-CL	η (%)	COSΦ	I _N (A)	T _{st} /T _N	T _{max} /T _N	I _{st} /I _N	LWdB(A)	J(kg.m ²)
071M	0.18	460	60	Y	1110	1.5	IE3	67.5	0.59	0.6	2.9	3.4	3.6	51	0.00115
071M	0.25	460	60	Y	1110	2.2	IE3	71.4	0.61	0.75	2.8	3.3	3.7	51	0.0013
080M	0.37	460	60	Y	1150	3.1	IE3	75.3	0.65	1	2.7	3.3	5.1	54	0.00227
080M	0.55	460	60	Y	1150	4.6	IE3	81.7	0.68	1.3	2.7	3.2	5.3	54	0.0032
090S	0.75	460	60	Y	1155	6.2	IE3	82.5	0.67	1.8	2.6	3.2	5.3	57	0.00418
090M	1.1	460	60	Y	1155	9.1	IE1	83	0.68	2.6	2.6	3.1	5.5	57	0.00599
100M	1.5	460	60	Y	1160	12.3	IE1	84.5	0.68	3.3	3.2	3.3	6.6	61	0.0117
112M	2.2	460	60	Y	1165	18.0	IE2	87.5	0.71	4.6	2.8</				

9 MU马达选型
技术参数 (IE4能效)

9 MU motor selection
technical data (efficiency IE4)

50Hz 380V 4P - 1500r/min S1

机座号	额定功率 (kW)	额定电压 (V)	额定频率 (Hz)	接法	额定转速 (r/min)	额定转矩 (N.m)	能效等级	效率 (%)	功率因数 (COS φ)	额定电流 (A)	启动转矩倍数	最大转矩倍数	启动电流倍数	空载噪声 (dB)	转动惯量 (kg.m ²)
Frame size	P _N (kW)	U _N (V)	F _N (Hz)	Conn.	n _N (r/min)	T _N (N.m)	IE-CL	η (%)	COS φ	I _N (A)	T _{st} /T _N	T _{max} /T _N	I _{st} /I _N	LWdB (A)	J (kg.m ²)
063M	0.12	220/380	50	△/Y	1335	0.86	IE4	69.8	0.69	0.66/0.38	2.3	2.3	4.5	52	0.00051
063M	0.18	220/380	50	△/Y	1335	1.3	IE4	74.7	0.71	0.89/0.52	2.3	2.3	5	55	0.00074
071M	0.25	220/380	50	△/Y	1375	1.7	IE4	77.9	0.71	1.2/0.69	2.3	2.3	5	55	0.00093
080M	0.37	220/380	50	△/Y	1375	2.6	IE4	81.1	0.72	1.7/0.96	2.2	2.3	5.5	56	0.00178
080M	0.55	220/380	50	△/Y	1420	3.7	IE4	83.9	0.74	2.4/1.4	2.3	2.3	6	56	0.00213
090S	0.75	220/380	50	△/Y	1420	5.0	IE4	85.7	0.74	3.1/1.8	2.3	2.3	7.5	59	0.00306
090L	1.1	220/380	50	△/Y	1435	7.3	IE4	87.2	0.75	4.4/2.6	2.3	2.3	7.5	59	0.00382
100L	1.5	220/380	50	△/Y	1435	10.0	IE4	88.2	0.76	5.9/3.4	2.3	2.3	7.5	64	0.00824
100L	2.2	220/380	50	△/Y	1455	14.4	IE4	89.5	0.79	8.2/4.7	2.3	2.3	7.5	64	0.00995
112M	3	220/380	50	△/Y	1450	19.8	IE4	90.4	0.8	10.9/6.3	2.3	2.3	7.5	65	0.0135
132S	4	380/660	50	△/Y	1460	26.2	IE4	91.1	0.8	8.4/4.8	2.1	2.3	8	71	0.0289
132M	5.5	380/660	50	△/Y	1470	35.7	IE4	91.9	0.8	11.4/6.6	2	2.3	8	71	0.0364
160M	7.5	380/660	50	△/Y	1470	48.7	IE4	92.6	0.81	15.2/8.8	1.7	2.3	8	73	0.0875
160L	11	380/660	50	△/Y	1475	71.2	IE4	93.3	0.83	21.6/12.5	2	2.3	8.5	73	0.115
180M	15	380/660	50	△/Y	1475	97.1	IE4	93.9	0.84	28.9/16.7	2	2.3	8.5	76	0.158
180L	18.5	380/660	50	△/Y	1475	119.8	IE4	94.2	0.85	35.1/20.3	2	2.3	8.5	76	0.184
200L	22	380/660	50	△/Y	1475	142.4	IE4	94.5	0.85	41.6/24	2	2.3	8.5	76	0.305
225S	30	380/660	50	△/Y	1475	194.2	IE4	94.9	0.85	56.5/32.6	2	2.3	8.3	78	0.533
225M	37	380/660	50	△/Y	1480	238.8	IE4	95.2	0.85	69.5/40	2	2.3	8.3	78	0.621
250M	45	380/660	50	△/Y	1480	290.4	IE4	95.4	0.85	84.4/48.6	2	2.3	8.5	79	0.768
280S	55	380/660	50	△/Y	1485	353.7	IE4	95.7	0.86	102/58.5	2	2.3	8.5	80	1.47
280M	75	380/660	50	△/Y	1490	480.7	IE4	96	0.87	137/78.6	2	2.3	8	80	1.67
280M	90	380/660	50	△/Y	1490	576.8	IE4	96.1	0.88	162/93.1	2	2.3	8	80	1.98

50Hz 380V 6P - 1000r/min S1

机座号	额定功率 (kW)	额定电压 (V)	额定频率 (Hz)	接法	额定转速 (r/min)	额定转矩 (N.m)	能效等级	效率 (%)	功率因数 (COS φ)	额定电流 (A)	启动转矩倍数	最大转矩倍数	启动电流倍数	空载噪声 (dB)	转动惯量 (kg.m ²)
Frame size	P _N (kW)	U _N (V)	F _N (Hz)	Conn.	n _N (r/min)	T _N (N.m)	IE-CL	η (%)	COS φ	I _N (A)	T _{st} /T _N	T _{max} /T _N	I _{st} /I _N	LWdB (A)	J (kg.m ²)
071M	0.18	220/380	50	△/Y	885	2.0	IE4	70.1	0.66	1.0/0.59	2.1	2	5.5	52	0.0013
080M	0.25	220/380	50	△/Y	885	2.7	IE4	74.1	0.66	1.4/0.71	2.1	2	6	54	0.00227
080M	0.37	220/380	50	△/Y	910	3.9	IE4	78	0.68	1.9/1.1	2.1	2	6	54	0.0032
090S	0.55	220/380	50	△/Y	920	5.7	IE4	80.9	0.68	2.6/1.5	2.1	2.1	6.5	57	0.00418
090L	0.75	220/380	50	△/Y	935	7.7	IE4	82.7	0.7	3.4/2	2.1	2.1	7.5	57	0.00599
100L	1.1	220/380	50	△/Y	935	11.2	IE4	84.5	0.7	4.9/2.9	2.1	2.1	7.5	61	0.0117
112M	1.5	220/380	50	△/Y	950	15.1	IE4	85.9	0.71	6.5/3.8	2.1	2.1	7.5	65	0.0171
132S	2.2	220/380	50	△/Y	960	21.9	IE4	87.4	0.71	9.3/5.4	2.1	2.1	7.5	69	0.0332
132M	3	220/380	50	△/Y	965	29.7	IE4	88.6	0.71	12.5/7.3	2	2.1	7.5	69	0.043
132M	4	380/660	50	△/Y	970	39.4	IE4	89.5	0.72	9.5/5.5	2	2.1	8	69	0.0571
160M	5.5	380/660	50	△/Y	975	53.9	IE4	90.5	0.72	12.8/7.4	2	2.1	8	73	0.104
160L	7.5	380/660	50	△/Y	975	73.5	IE4	91.3	0.76	16.4/9.5	2	2.1	8	73	0.146
180L	11	380/660	50	△/Y	975	107.7	IE4	92.3	0.77	23.5/13.6	2	2.1	8.5	73	0.232
200L	15	380/660	50	△/Y	980	146.2	IE4	92.9	0.8	30.7/17.7	2	2.1	8.5	73	0.374
200L	18.5	380/660	50	△/Y	980	180.3	IE4	93.4	0.8	37.6/21.7	2	2.1	8.5	73	0.417
225M	22	380/660	50	△/Y	980	214.4	IE4	93.7	0.81	44/25.4	2	2.1	8.5	74	0.625
250M	30	380/660	50	△/Y	985	290.9	IE4	94.2	0.82	59/34	2	2.1	8.3	76	1.063
280S	37	380/660	50	△/Y	985	358.7	IE4	94.5	0.83	71.7/41.3	2	2.1	8.3	78	1.675
280M	45	380/660	50	△/Y	990	434.1	IE4	94.8	0.83	86.9/50	2	2	8.5	78	2.02
280M	55	380/660	50	△/Y	990	530.6	IE4	95.1	0.84	105/60.3	2	2	8.5	78	2.22

50Hz 400V 4P - 1500r/min S1

机座号	额定功率 (kW)	额定电压 (V)	额定频率 (Hz)	接法	额定转速 (r/min)	额定转矩 (N.m)	能效等级	效率 (%)	功率因数 (COS φ)	额定电流 (A)	启动转矩倍数	最大转矩倍数	启动电流倍数	空载噪声 (dB)	转动惯量 (kg.m ²)
Frame size	P _N (kW)	U _N (V)	F _N (Hz)	Conn.	n _N (r/min)	T _N (N.m)	IE-CL	η (%)	COS φ	I _N (A)	T _{st} /T _N	T _{max} /T _N	I _{st} /I _N	LWdB (A)	J (kg.m ²)
063M	0.12	230/400	50	△/Y	1335	0.86	IE4	69.8	0.69	0.63/0.36	2.3	2.3	4.5	52	0.00051
063M	0.18	230/400	50	△/Y	1335	1.3	IE4	74.7	0.71	0.85/0.49	2.3	2.3	5	55	0.00074
071M	0.25	230/400	50	△/Y	1375	1.7	IE4	77.9	0.71	1.2/0.66	2.3	2.3	5	55	0.00093
080M	0.37	230/400	50	△/Y	1375	2.6	IE4	81.1	0.72	1.6/0.9	2.2	2.3	5.5	56	0.00178
080M	0.55	230/400	50	△/Y	1420	3.7	IE4	83.9	0.74	2.3/1.3	2.3	2.3	6	56	0.00213
090S	0.75	230/400	50	△/Y	1420	5.0	IE4	85.7	0.74	3/1.7	2.3	2.3	7.5	59	0.00306
090L	1.1	230/400	50	△/Y	1435	7.3	IE4	87.2	0.75	4.3/2.5	2.3	2.3	7.5	59	0.00382
100L	1.5	230/400	50	△/Y	1435	10.0	IE4	88.2	0.76	5.7/3.3	2.3	2.3	7.5	64	0.00824
100L	2.2	230/400	50	△/Y	1455	14.4	IE4	89.5	0.79	7.8/4.5	2.3	2.3	7.5	64	0.00995
112M	3	230/400	50	△/Y	1450	19.8	IE4	90.4	0.8	10.5/6	2.3	2.3	7.5	65	0.0135
132S	4	400/690	50	△/Y	1460	26.2	IE4	91.1	0.8	8/4.6	2.1	2.3	8	71	0.0289
132M	5.5	400/690	50	△/Y	1470	35.7	IE4	91.9	0.8	10.8/6.3	2	2.3	8	71	0.0364
160M	7.5	400/690	50	△/Y	1470	48.7	IE4	92.6	0.81	14.5/8.4	1.7	2.3	8	73	0.0875
160L	11	400/690	50	△/Y	1475	71.2	IE4	93.3	0.83	20.5/11.9	2	2.3	8.5	73	0.115
180M	15	400/690	50	△/Y	1475	97.1	IE4	93.9	0.84	27.5/16	2	2.3	8.5	76	0.158
180L	18.5	400/690	50	△/Y	1475	119.8	IE4	94.2	0.85	33.4/19.4	2	2.3	8.5	76	0.184
200L	22	400/690	50	△/Y	1475	142.4	IE4	94.5	0.85	39.5/23	2	2.3	8.5	76	0.305
225S	30	400/690	50	△/Y	1475	194.2	IE4	94.9	0.85	53.7/31.2	2	2.3	8.3	78	0.533
225M	37	400/690	50	△/Y	1480	238.8	IE4	95.2	0.85	66/38.3	2	2.3	8.3	78	0.621
250M	45	400/690	50	△/Y	1480	290.4	IE4	95.4	0.85	80/46.5	2	2.3	8.5	79	0.768
280S	55	400/690	50	△/Y	1485	353.7	IE4	95.7	0.86	96.5/56	2	2.3	8.5	80	1.47
280M	75	400/690	50	△/Y	1490	480.7	IE4	96	0.87	130/75.2	2	2.3	8	80	1.67
280M	90	400/690	50	△/Y	1490	576.8	IE4	96.1	0.88	154/89	2	2.3	8	80	1.98

50Hz 400V 6P - 1000r/min S1

机座号	额定功率 (kW)	额定电压 (V)	额定频率 (Hz)	接法	额定转速 (r/min)	额定转矩 (N.m)	能效等级	效率 (%)	功率因数 (COS φ)	额定电流 (A)	启动转矩倍数	最大转矩倍数	启动电流倍数	空载噪声 (dB)	转动惯量 (kg.m ²)
Frame size	P _N (kW)	U _N (V)	F _N (Hz)	Conn.	n _N (r/min)	T _N (N.m)	IE-CL	η (%)	COS φ	I _N (A)	T _{st} /T _N	T _{max} /T _N	I _{st} /I _N	LWdB (A)	J (kg.m ²)
071M	0.18	230/400	50	△/Y	885	2.0	IE4	70.1	0.66	0.98/0.56	2.1	2	5.5	52	0.0013
080M	0.25	230/400	50	△/Y	885	2.7	IE4	74.1	0.66	1.3/0.74	2.1	2	6	54	0.00227
080M	0.37	230/400	50	△/Y	910	3.9	IE4	78	0.68	1.8/1	2.1	2	6	54	0.0032
090S	0.55	230/400	50	△/Y	920	5.7	IE4	80.9	0.68	2.5/1.5	2.1	2.1	6.5	57	0.00418
090L	0.75	230/400	50	△/Y	935	7.7	IE4	82.7	0.7	3.3/1.9	2.1	2.1			

MU马达选型
技术参数(续)

MU motor selection
technical data(continue)

60Hz 440V 4P-1800r/min S1

机座号	额定功率(kW)	额定电压(V)	额定频率(Hz)	接法	额定转速(r/min)	额定转矩(N.m)	能效等级	效率(%)	功率因数(COSφ)	额定电流(A)	启动转矩倍数	最大转矩倍数	启动电流倍数	空载噪声(dB)	转动惯量(kg.m ²)
Frame size	P _N (kW)	U _N (V)	F _N (Hz)	Conn.	n _N (r/min)	T _N (N.m)	IE-CL	η (%)	COSΦ	I _N (A)	T _{st} /T _N	T _{max} /T _N	I _{st} /I _N	LWdB(A)	J(kg.m ²)
063M	0.12	440	60	Y	1665	0.69	IE4	70	0.66	0.34	2.3	2.3	4.5	52	0.00051
063M	0.18	440	60	Y	1665	1.0	IE4	74	0.68	0.47	2.3	2.3	5	55	0.00074
071M	0.25	440	60	Y	1695	1.4	IE4	77	0.69	0.62	2.3	2.3	5	55	0.00093
080M	0.37	440	60	Y	1695	2.1	IE4	81.5	0.7	0.85	2.2	2.3	5.5	56	0.00178
080M	0.55	440	60	Y	1730	3.0	IE4	84	0.72	1.2	2.3	2.3	6	56	0.00213
090S	0.75	440	60	Y	1735	4.1	IE4	85.5	0.72	1.6	2.3	2.3	7.5	59	0.00306
090L	1.1	440	60	Y	1750	6.0	IE4	87.5	0.73	2.3	2.3	2.3	7.5	59	0.00382
100L	1.5	440	60	Y	1750	8.2	IE4	88.5	0.74	3	2.3	2.3	7.5	64	0.00824
100L	2.2	440	60	Y	1760	11.9	IE4	91	0.77	4.2	2.3	2.3	7.5	64	0.00995
112M	3	440	60	Y	1755	16.3	IE4	91	0.78	5.6	2.3	2.3	7.5	65	0.0135
132S	4	440	60	△	1765	21.6	IE4	91.2	0.79	7.3	2.1	2.3	8	71	0.0289
132M	5.5	440	60	△	1775	29.6	IE4	92.4	0.79	9.9	2	2.3	8	71	0.0364
160M	7.5	440	60	△	1775	40.4	IE4	92.4	0.8	13.3	1.7	2.3	8	73	0.0875
160L	11	440	60	△	1780	59.0	IE4	93.6	0.82	18.8	2	2.3	8.5	73	0.115
180M	15	440	60	△	1780	80.5	IE4	94.1	0.83	25.2	2	2.3	8.5	76	0.158
180L	18.5	440	60	△	1775	99.5	IE4	94.5	0.84	30.6	2	2.3	8.5	76	0.184
200L	22	440	60	△	1775	118.4	IE4	94.5	0.84	36.4	2	2.3	8.5	76	0.305
225S	30	440	60	△	1780	161.0	IE4	95	0.84	49.4	2	2.3	8.3	78	0.533
225M	37	440	60	△	1785	198.0	IE4	95.4	0.84	60.6	2	2.3	8.3	78	0.621
250M	45	440	60	△	1785	240.8	IE4	95.4	0.84	73.7	2	2.3	8.5	79	0.768
280S	55	440	60	△	1785	294.3	IE4	95.8	0.85	88.6	2	2.3	8.5	80	1.47
280M	75	440	60	△	1790	400.1	IE4	96.2	0.86	119	2	2.3	8	80	1.67
280M	90	440	60	△	1790	480.2	IE4	96.2	0.87	141	2	2.3	8	80	1.98

60Hz 440V 6P-1200r/min S1

机座号	额定功率(kW)	额定电压(V)	额定频率(Hz)	接法	额定转速(r/min)	额定转矩(N.m)	能效等级	效率(%)	功率因数(COSφ)	额定电流(A)	启动转矩倍数	最大转矩倍数	启动电流倍数	空载噪声(dB)	转动惯量(kg.m ²)
Frame size	P _N (kW)	U _N (V)	F _N (Hz)	Conn.	n _N (r/min)	T _N (N.m)	IE-CL	η (%)	COSΦ	I _N (A)	T _{st} /T _N	T _{max} /T _N	I _{st} /I _N	LWdB(A)	J(kg.m ²)
071M	0.18	440	60	Y	1110	1.5	IE4	72	0.63	0.52	2.1	2	5.5	52	0.0013
080M	0.25	440	60	Y	1110	2.2	IE4	75.5	0.63	0.69	2.1	2	6	54	0.00227
080M	0.37	440	60	Y	1130	3.1	IE4	78.5	0.66	0.94	2.1	2	6	54	0.0032
090S	0.55	440	60	Y	1135	4.6	IE4	82.5	0.66	1.3	2.1	2.1	6.5	57	0.00418
090L	0.75	440	60	Y	1140	6.3	IE4	84	0.68	1.8	2.1	2.1	7.5	57	0.00599
100L	1.1	440	60	Y	1140	9.2	IE4	88.5	0.68	2.4	2.1	2.1	7.5	61	0.0117
112M	1.5	440	60	Y	1160	12.3	IE4	89.5	0.69	3.2	2.1	2.1	7.5	65	0.0171
132S	2.2	440	60	Y	1170	18.0	IE4	90.2	0.69	4.6	2.1	2.1	7.5	69	0.0332
132M	3	440	60	Y	1170	24.5	IE4	90.2	0.7	6.3	2	2.1	7.5	69	0.043
132M	4	440	60	△	1170	32.6	IE4	90.4	0.71	8.2	2	2.1	8	69	0.0571
160M	5.5	440	60	△	1175	44.7	IE4	91.7	0.71	11.1	2	2.1	8	73	0.104
160L	7.5	440	60	△	1175	61.0	IE4	92.4	0.75	14.2	2	2.1	8	73	0.146
180L	11	440	60	△	1175	89.4	IE4	93	0.76	20.5	2	2.1	8.5	73	0.232
200L	15	440	60	△	1185	120.9	IE4	93	0.79	26.8	2	2.1	8.5	73	0.374
200L	18.5	440	60	△	1185	149.1	IE4	94.1	0.79	32.7	2	2.1	8.5	73	0.417
225M	22	440	60	△	1185	177.3	IE4	94.1	0.8	38.4	2	2.1	8.5	74	0.625
250M	30	440	60	△	1185	241.8	IE4	95	0.81	51.2	2	2.1	8.3	76	1.063
280S	37	440	60	△	1185	298.2	IE4	95	0.82	62.4	2	2.1	8.3	78	1.675
280M	45	440	60	△	1190	361.1	IE4	95.4	0.82	75.5	2	2	8.5	78	2.02
280M	55	440	60	△	1190	441.4	IE4	95.4	0.83	91.2	2	2	8.5	78	2.22

60Hz 460V 4P-1800r/min S1

机座号	额定功率(kW)	额定电压(V)	额定频率(Hz)	接法	额定转速(r/min)	额定转矩(N.m)	能效等级	效率(%)	功率因数(COSφ)	额定电流(A)	启动转矩倍数	最大转矩倍数	启动电流倍数	空载噪声(dB)	转动惯量(kg.m ²)
Frame size	P _N (kW)	U _N (V)	F _N (Hz)	Conn.	n _N (r/min)	T _N (N.m)	IE-CL	η (%)	COSΦ	I _N (A)	T _{st} /T _N	T _{max} /T _N	I _{st} /I _N	LWdB(A)	J(kg.m ²)
063M	0.12	460	60	Y	1665	0.69	IE4	70	0.66	0.33	2.3	2.3	4.5	52	0.00051
063M	0.18	460	60	Y	1665	1.0	IE4	74	0.68	0.45	2.3	2.3	5	55	0.00074
071M	0.25	460	60	Y	1695	1.4	IE4	77	0.69	0.59	2.3	2.3	5	55	0.00093
080M	0.37	460	60	Y	1695	2.1	IE4	81.5	0.7	0.81	2.2	2.3	5.5	56	0.00178
080M	0.55	460	60	Y	1730	3.0	IE4	84	0.72	1.1	2.3	2.3	6	56	0.00213
090S	0.75	460	60	Y	1735	4.1	IE4	85.5	0.72	1.5	2.3	2.3	7.5	59	0.00306
090L	1.1	460	60	Y	1750	6.0	IE4	87.5	0.73	2.2	2.3	2.3	7.5	59	0.00382
100L	1.5	460	60	Y	1750	8.2	IE4	88.5	0.74	2.9	2.3	2.3	7.5	64	0.00824
100L	2.2	460	60	Y	1760	11.9	IE4	91	0.77	3.9	2.3	2.3	7.5	64	0.00995
112M	3	460	60	Y	1755	16.3	IE4	91	0.78	5.3	2.3	2.3	7.5	65	0.0135
132S	4	460	60	△	1765	21.6	IE4	91.2	0.79	7.0	2.1	2.3	8	71	0.0289
132M	5.5	460	60	△	1775	29.6	IE4	92.4	0.79	9.5	2	2.3	8	71	0.0364
160M	7.5	460	60	△	1775	40.4	IE4	92.4	0.8	12.7	1.7	2.3	8	73	0.0875
160L	11	460	60	△	1780	59.0	IE4	93.6	0.82	18.0	2	2.3	8.5	73	0.115
180M	15	460	60	△	1780	80.5	IE4	94.1	0.83	24.1	2	2.3	8.5	76	0.158
180L	18.5	460	60	△	1775	99.5	IE4	94.5	0.84	29.3	2	2.3	8.5	76	0.184
200L	22	460	60	△	1775	118.4	IE4	94.5	0.84	34.8	2	2.3	8.5	76	0.305
225S	30	460	60	△	1780	161.0	IE4	95	0.84	47.2	2	2.3	8.3	78	0.533
225M	37	460	60	△	1785	198.0	IE4	95.4	0.84	58.0	2	2.3	8.3	78	0.621
250M	45	460	60	△	1785	240.8	IE4	95.4	0.84	70.5	2	2.3	8.5	79	0.768
280S	55	460	60	△	1785	294.3	IE4	95.8	0.85	84.8	2	2.3	8.5	80	1.47
280M	75	460	60	△	1790	400.1	IE4	96.2	0.86	114.0	2	2.3	8	80	1.67
280M	90	460	60	△	1790	480.2	IE4	96.2	0.87	135.0	2	2.3	8	80	1.98

60Hz 460V 6P-1200r/min S1

机座号	额定功率(kW)	额定电压(V)	额定频率(Hz)	接法	额定转速(r/min)	额定转矩(N.m)	能效等级	效率(%)	功率因数(COSφ)	额定电流(A)	启动转矩倍数	最大转矩倍数	启动电流倍数	空载噪声(dB)	转动惯量(kg.m ²)
Frame size	P _N (kW)	U _N (V)	F _N (Hz)	Conn.	n _N (r/min)	T _N (N.m)	IE-CL	η (%)	COSΦ	I _N (A)	T _{st} /T _N	T _{max} /T _N	I _{st} /I _N	LWdB(A)	J(kg.m ²)
071M	0.18	460	60	Y	1110	1.5	IE4	72	0.63	0.50	2.1	2	5.5	52	0.0013
080M	0.25	460	60	Y	1110	2.2	IE4	75.5	0.63	0.66	2.1	2	6	54	0.00227
080M	0.37	460	60	Y	1130	3.1	IE4	78.5	0.66	0.90	2.1	2	6	54	0.0032
090S	0.55	460	60	Y	1135	4.6	IE4	82.5	0.66	1.3	2.1	2.1	6.5	57	0.00418
090L	0.75	460	60	Y	1140	6.3	IE4	84	0.68	1.6	2.1	2.1	7.5	57	0.00599
100L	1.1	460	60	Y	1140	9.2	IE4	88.5	0.68	2.3	2.1	2.1	7.5	61	0.0117
112M	1.5	460	60	Y	1160	12.3	IE4	89.5	0.69	3.0	2.1	2.1	7.5	65	0.0171
132S	2.2	460	60	Y	1170	18.0	IE4	90.2	0.69	4.4	2.1	2.1	7.5	69	0.0332
132M	3	460	60	Y	1170	24.5	IE4	90.2	0.7	6.0	2	2.1	7.5	69	0.043
132M	4	460	60	△	1170	32.6	IE4	90.4	0.71	7.8	2	2.1	8	69	0.0571
160M	5.5	460	60	△	1175	44.7	IE4	91.7	0.71	10.6	2	2.1	8	73	0.104
160L	7.5	460	60	△	1175	61.0	IE4	92.4							

10 MP马达外形尺寸

10 MP motor dimensions

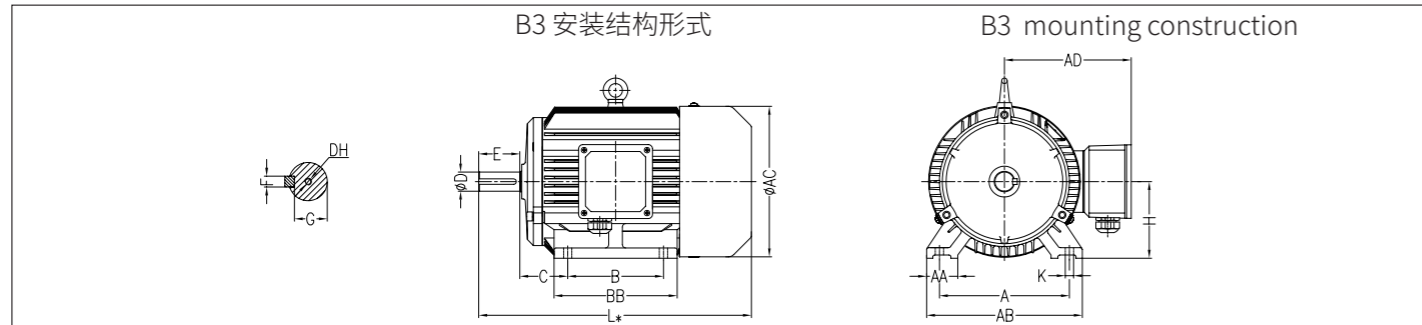

机座Frame 号 size	极 No. of 数 poles	尺寸 (mm)															Dimension (mm)		
		A	B	C	D	E	F	G	H	K	AA	AB	AC	AD	BB	DH			
063M	4	100	80	40	11	23	4	8.5	63	7	35	124	124	122	102	CM4L10/7.4			
071M	4、6	112	90	45	14	30	5	11	71	8	39	141	139	130	115	CM5L10/8.8			
080M	4、6	125	100	50	19	40	6	15.5	80	10	40	153	159	151	132	CM6L12/10.5			
090S	4、6	140	100	56	24	50	8	20	90	10	44	166	176	158	160	CM8L12/13.2			
090M	4、6	140	125	56	24	50	8	20	90	10	44	166	176	158	160	CM8L12/13.2			
100M	4、6	160	140	63	28	60	8	24	100	12	48	190	199	171	176	CM10L15/16.3			
112M	6	190	140	70	28	60	8	24	112	12	45	226	220	181	180	CM10L15/16.3			
112L	4	190	140	70	28	60	8	24	112	12	45	226	220	181	180	CM10L15/16.3			
132S	6	216	140	89	38	80	10	33	132	12	55	262	259	203	186	CM12L20/19.8			
132M	4	216	140	89	38	80	10	33	132	12	55	262	259	203	224	CM12L20/19.8			
132M	6	216	178	89	38	80	10	33	132	12	55	262	259	203	224	CM12L20/19.8			
132L	4、6	216	178	89	38	80	10	33	132	12	55	262	259	203	262	CM12L20/19.8			
160S	6	254	210	108	42	110	12	37	160	14.5	65	314	314	248	260	CM16L25/25.3			
160M	4	254	210	108	42	110	12	37	160	14.5	65	314	314	248	304	CM16L25/25.3			
160M	6	254	254	108	42	110	12	37	160	14.5	65	314	314	248	304	CM16L25/25.3			
160L	4	254	254	108	42	110	12	37	160	14.5	65	314	314	248	334	CM16L25/25.3			
180M	4	279	241	121	48	110	14	42.5	180	14.5	70	349	356	264	349	CM16L25/25.3			
180M	6	279	279	121	48	110	14	42.5	180	14.5	70	349	356	264	349	CM16L25/25.3			
180L	4	279	279	121	48	110	14	42.5	180	14.5	70	349	356	264	397	CM16L25/25.3			
200M	4、6	318	305	133	55	110	16	49	200	18.5	70	388	398	296	369	CM20L30/31.3			
225M	4、6	356	286	149	60	140	18	53	225	18.5	75	431	446	319	393	CM20L30/31.3			
	4、6	356	311	149	60	140	18	53	225	18.5	75	431	446	319	393	CM20L30/31.3			
250M	4、6	406	349	168	65	140	18	58	250	24	80	486	485	353	445	CM20L30/31.3			
280S	4、6	457	368	190	75	140	20	67.5	280	24	85	537	547	380	485	CM20L30/31.3			
280M	4、6	457	419	190	75	140	20	67.5	280	24	85	537	547	380	536	CM20L30/31.3			

B5安装结构形式

B5 mounting construction

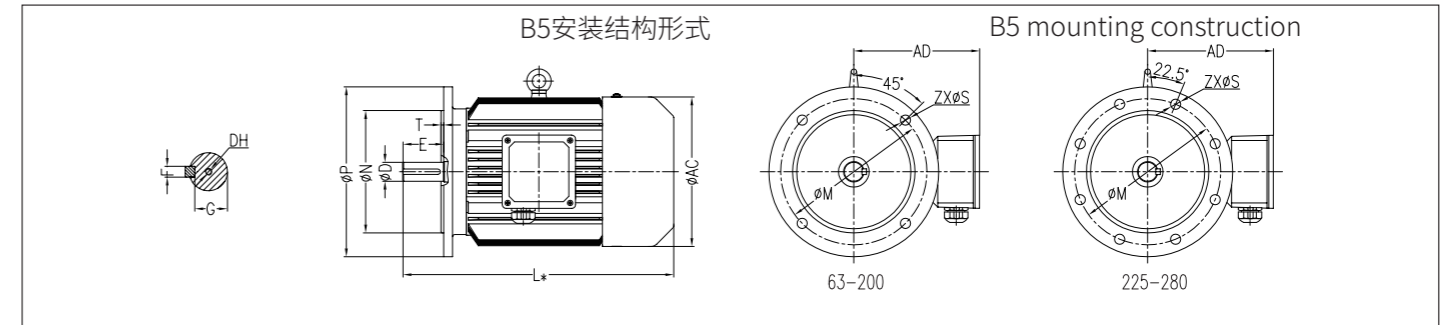

机座Frame 号 size	极 No. of 数 poles	尺寸 (mm)															Dimension (mm)		
		D	E	F	G	M	N	P	S	T	Z	AC	AD	DH					
063M	4	11	23	4	8.5	115	95	140	10	3	4	124	122	CM4L10/7.4					
071M	4、6	14	30	5	11	130	110	160	10	3	4	139	130	CM5L10/8.8					
080M	4、6	19	40	6	15.5	165	130	200	12	3.5	4	159	151	CM6L12/10.5					
090S	4、6	24	50	8	20	165	130	200	12	3.5	4	176	158	CM8L12/13.2					
090M	4、6	24	50	8	20	165	130	200	12	3.5	4	176	158	CM8L12/13.2					
100M	4、6	28	60	8	24	215	180	250	14.5	4	4	199	171	CM10L15/16.3					
112M	6	28	60	8	24	215	180	250	14.5	4	4	220	181	CM10L15/16.3					
112L	4	28	60	8	24	215	180	250	14.5	4	4	220	181	CM10L15/16.3					
132S	6	38	80	10	33	265	230	300	15	4	4	259	203	CM12L20/19.8					
132M	4、6	38	80	10	33	265	230	300	15	4	4	259	203	CM12L20/19.8					
132L	4、6	38	80	10	33	265	230	300	15	4	4	259	203	CM12L20/19.8					
160S	6	42	110	12	37	300	250	350	19	5	4	314	248	CM16L25/25.3					
160M	4、6	42	110	12	37	300	250	350	19	5	4	314	248	CM16L25/25.3					
160L	4	42	110	12	37	300	250	350	19	5	4	314	248	CM16L25/25.3					
180M	4、6	48	110	14	42.5	300	250	350	19	5	4	356	264	CM16L25/25.3					
180L	4	48	110	14	42.5	300	250	350	19	5	4	356	264	CM16L25/25.3					
200M	4、6	55	110	16	49	350	300	400	19	5	4	398	296	CM20L30/31.3					
225M	4、6	60	140	18	53	400	350	450	19	5	8	446	319	CM20L30/31.3					
250M	4、6	65	140	18	58	500	450	550	19	5	8	485	353	CM20L30/31.3					
280S	4、6	75	140	20	67.5	500	450	550	19	5	8	547	380	CM20L30/31.3					
280M	4、6	75	140	20	67.5	500	450	550	19	5	8	547	380	CM20L30/31.3					

B14B安装结构形式

B14 mounting construction

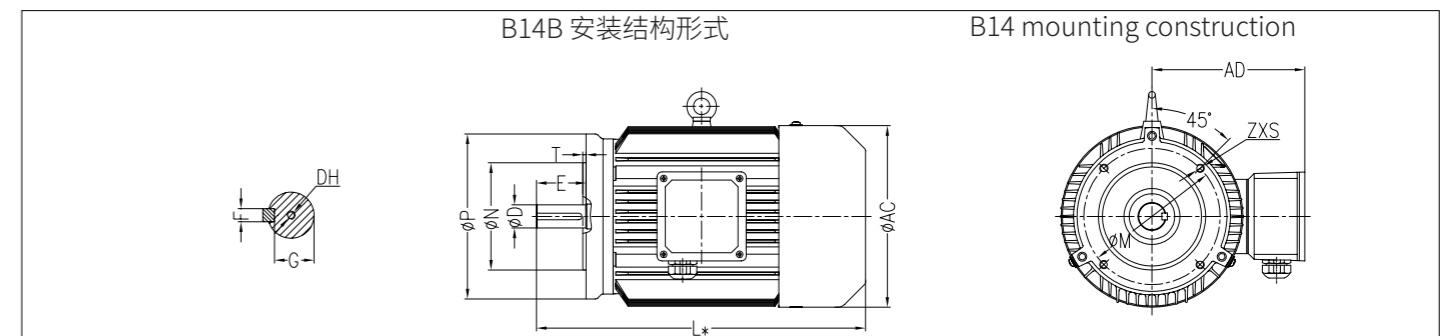

机座Frame 号 size	极 No. of 数 poles	尺寸 (mm)															Dimension (mm)		
		D	E	F	G	M	N	P	S	T	Z	AC	AD	DH					
071M	4、6	14	30	5	11	115	95	140	M8	3	4	139	130	CM5L10/8.8					
080M	4、6	19	40	6	15.5	130	110	160	M8	3.5	4	159	151	CM6L12/10.5					
090S	4、6	24	50	8	20	130	110	160	M8	3.5	4	176	158	CM8L12/13.2					
090M	4、6	24	50	8	20	130	110	160	M8	3.5	4	176	158	CM8L12/13.2					
100M	4、6	28	60	8	24	165	130	200	M10	4	4	199	171	CM10L15/16.3					
112M	6	28	60	8	24	165	130	200	M10	4	4	220	181	CM10L15/16.3					
112L	4	28	60	8	24	165	130	200	M10	4	4	220	181	CM10L15/16.3					
132S	6	38	80	10	33	215	180	250	M12	4	4	259	203	CM12L20/19.8					
132M	4、6	38	80	10	33	215	180	250	M12	4	4	259	203	CM12L20/19.8					
132L	4、6	38	80	10	33	215	180	250	M12	4	4	259	203	CM12L20/19.8					

MP马达外形尺寸 (续)

MP motor dimensions (continue)

机座号 Frame size	4极 4-pole 功率 power (kW) (kW)	MP马达长度尺寸和重量 MP motor length and weight						马达尺寸 Motor length L*(mm) L* (mm)							马达重量 Motor weight (kg) Motor weight (kg)									
		L1	L2	L3	L5	L6	L7	M1	M2	M3	M5	M6	M7	M1	M2	M3	M5	M6	M7					
																				L1	L2	L3	L5	L6
063M	0.12	215	270	250	305	/	/	7	7.5	8.5	9	/	/											
063M	0.18	215	270	250	305	/	/	8	8.5	9.5	10	/	/											
071M	0.25	244	289	284	339	339	379	9	10	10.5	11.5	10.5	12.5											
071M	0.37	244	289	284	339	339	379	10	11	11.5	12.5	11.5	13.5											
080M	0.55	301	346	361	411	411	456	15	16	19	20	16.5	21											
080M	0.75	301	346	361	411	411	456	16	17	20	21	17.5	22											
090S	1.1	334	379	389	439	439	484	21	22	25	26	22.5	27											
090M	1.5	359	404	414	464	464	509	23	24	27	28	24.5	29											
100M	2.2	409	449	484	524	524	579	32	33	40	41	34	41											
100M	3	409	449	484	524	524	579	36	37	44	45	38	45											
112L	4	472	522	547	579	579	652	56	57	64	65	58	66											
132M	5.5	503	553	583	628	628	683	77	79	88	90	80	91											
132L	7.5	541	591	621	666	666	721	88	90	99	101	91	102											
160M	11	640	680	735	770	770	820	129	131	150	151	132	152											
160L	15	675	710	770	800	800	850	161	163	182	183	164	184											
180M	18.5	706	736	816	841	841	886	200	202	232	233	203	235											
180L	22	754	784	864	889	889	934	220	222	252	253	223	255											
200M	30	797	802	912	917	917	962	280	280	330	328	281	330											
225M	37	869	899	984	1014	1014	1059	345	347	395	396	349	398											
225M	45	869	899	984	1014	1014	1059	365	367	415	416	369	418											
250M	55	964	979	1104	1114	1114	1169	470	471	575	570	470	572											
280S	75	1011	1041	1151	1186	1186	1231	630	632	735	733	633	735											
280M	90	1062	1092	1202	1237	1237	1282	710	712	815	813	713	815											

机座号 Frame size	6极 6-pole 功率 power (kW) (kW)	MP马达长度尺寸和重量 MP motor length and weight						马达尺寸 Motor length L*(mm) L* (mm)							马达重量 Motor weight (kg) Motor weight (kg)									
		L1	L2	L3	L5	L6	L7	M1	M2	M3	M5	M6	M7	M1	M2	M3	M5	M6	M7					
																				L1	L2	L3	L5	L6
71M	0.18	244	289	284	339	339	379	10.5	11.5	12	13	12	14											
71M	0.25	244	289	284	339	339	379	12	13	13.5	14.5	13.5	15.5											
80M	0.37	301	346	361	411	411	456	15	16	19	20	16.5	21											
80M	0.55	301	346	361	411	411	456	17	18	21	22	18.5	23											
90S	0.75	334	379	389	439	439	489	20	21	24	25	21.5	26											
90M	1.1	359	404	414	464	464	514	25	26	29	30	26.5	31											
100M	1.5	409	449	484	544	544	579	32	33	40	41	34	42											
112M	2.2	472	522	547	579	579	652	56	57	64	65	58	66											
132S	3	503	553	583	628	628	683	77	79	88	90	80	91											
132M	4	503	553	583	628	628	683	69	71	80	82	72	83											
132L	5.5	541	591	621	666	666	721	88	90	99	101	91	102											
160S	7.5	645	685	740	775	775	825	129	131	150	151	132	152											
160M	11	675	710	770	800	800	850	161	163	182	183	164	184											
180M	15	706	736	816	841	841	886	200	202	232	233	203	235											
200M	18.5	797	802	912	917	917	962	280	280	330	328	281	330											
200M	22	797	802	912	917	917	962	260	260	310	308	261	310											
225M	30	869	899	984	1014	1014	1059	330	332	380	381	334	383											
250M	37	959	979	1099	1114	1114	1169	435	436	540	535	435	537											
280S	45	1011	1041	1151	1186	1186	1231	545	547	650	648	548	650											
280M	55	1062	1092	1202	1237	1237	1282	605	607	710	708	608	710											

11 MU马达外形尺寸

11 MU motor dimensions

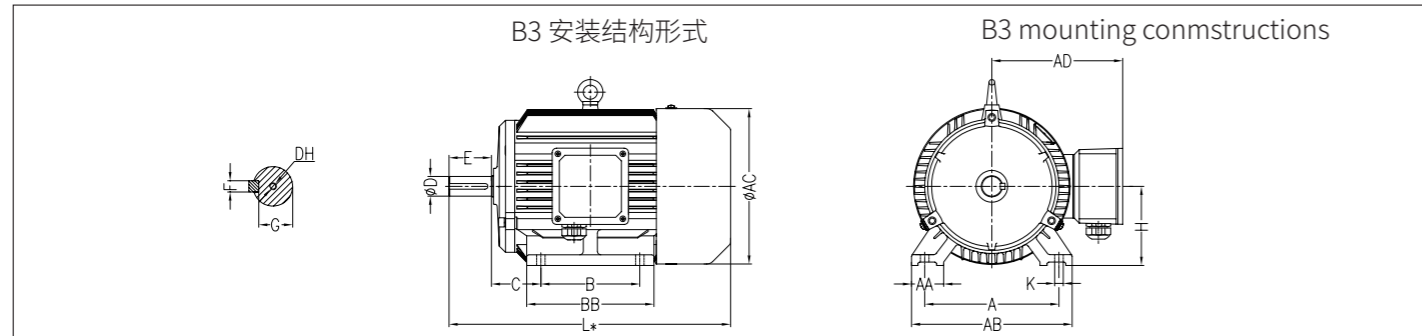

机座 Frame 号 size	极 No. of 数 poles	尺寸 (mm) Dimension (mm)														
		A	B	C	D	E	F	G	H	K	AA	AB	AC	AD	BB	DH
063M	4	100	80	40	11	23	4	8.5	63	7	35	124	124	122	102	CM4L10/7.4
071M	4、6	112	90	45	14	30	5	11	71	8	39	142	139	130	115	CM5L10/8.8
080M	4、6	125	100	50	19	40	6	15.5	80	10	40	153	159	151	132	CM6L12/10.5
090S	4、6	140	100	56	24	50	8	20	90	10	44	166	176	158	160	CM8L12/13.2
090L	4、6	140	125	56	24	50	8	20	90	10	44	166	176	158	160	CM8L12/13.2
100L	4、6	160	140	63	28	60	8	24	100	12	48	190	199	171	176	CM10L15/16.3
112M	4、6	190	140	70	28	60	8	24	112	12	45	226	220	181	180	CM10L15/16.3
132S	4、6	216	140	89	38	80	10	33	132	12	55	262	259	203	186	CM12L20/19.8
132M	4、6	216	178	89	38	80	10	33	132	12	55	262	259	203	224	CM12L20/19.8
160M	4、6	254	210	108	42	110	12	37	160	14.5	65	314	314	248	304	CM16L25/25.3
160L	4、6	254	254	108	42	110	12	37	160	14.5	65	314	314	248	334	CM16L25/25.3
180M	4	279	241	121	48	110	14	42.5	180	14.5	70	349	356	264	349	CM16L25/25.3
180L	4、6	279	279	121	48	110	14	42.5	180	14.5	70	349	356	264	397	CM16L25/25.3
200L	4、6	318	305	133	55	110	16	49	200	18.5	70	388	398	296	369	CM20L30/31.3
225S	4	356	286	149	60	140	18	53	225	18.5	75	431	446	319	393	CM20L30/31.3
225M	4、6	356	311	149	60	140	18	53	225	18.5	75	431	446	319	393	CM20L30/31.3
250M	4、6	406	349	168	65	140	18	58	250	24	80	486	485	353	445	CM20L30/31.3
280S	4、6	457	368	190	75	140	20	67.5	280	24	85	537	547	380	489	CM20L30/31.3
280M	4、6	457	419	190	75	140	20	67.5	280	24	85	537	547	380	540	CM20L30/31.3

B5 安装结构形式

B5 mounting constructions

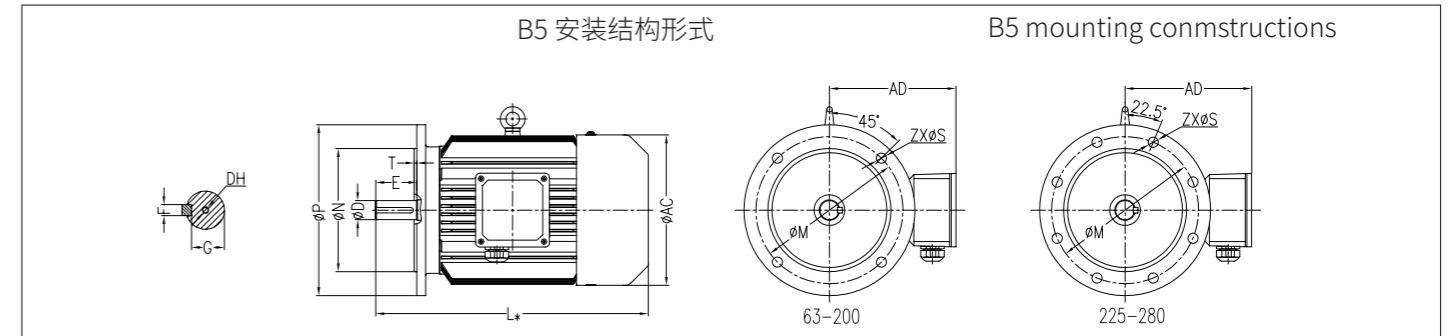

机座 Frame 号 size	极 No. of 数 poles	尺寸 (mm) Dimension (mm)														
		D	E	F	G	M	N	P	S	T	Z	AC	AD	DH		
063M	4	11	23	4	8.5	115	95	140	10	3	4	124	122	CM4L10/7.4		
071M	4、6	14	30	5	11	130	110	160	10	3	4	139	130	CM5L10/8.8		
080M	4、6	19	40	6	15.5	165	130	200	12	3.5	4	159	151	CM6L12/10.5		
090S	4、6	24	50	8	20	165	130	200	12	3.5	4	176	158	CM8L12/13.2		
090L	4、6	24	50	8	20	165	130	200	12	3.5	4	176	158	CM8L12/13.2		
100L	4、6	28	60	8	24	215	180	250	14.5	4	4	199	171	CM10L15/16.3		
112M	4、6	28	60	8	24	215	180	250	14.5	4	4	220	181	CM10L15/16.3		
132S	4、6	38	80	10	33	265	230	300	15	4	4	259	203	CM12L20/19.8		
132M	4、6	38	80	10	33	265	230	300	15	4	4	259	203	CM12L20/19.8		
160M	4、6	42	110	12	37	300	250	350	19	5	4	314	248	CM16L25/25.3		
160L	4、6	42	110	12	37	300	250	350	19	5	4	314	248	CM16L25/25.3		
180M	4	48	110	14	42.5	300	250	350	19	5	4	356	264	CM16L25/25.3		
180L	4、6	48	110	14	42.5	300	250	350	19	5	4	356	264	CM16L25/25.3		
200L	4、6	55	110	16	49	350	300	400	19	5	4	398	296	CM20L30/31.3		
225S	4	60	140	18	53	400	350	450	19	5	4	446	319	CM20L30/31.3		
225M	4、6	60	140	18	53	400	350	450	19	5	8	446	319	CM20L30/31.3		
250M	4、6	65	140	18	58	500	450	550	19	5	8	485	353	CM20L30/31.3		
280S	4、6	75	140	20	67.5	500	450	550	19	5	8	547	380	CM20L30/31.3		
280M	4、6	75	140	20	67.5	500	450	550	19	5	8	547	380	CM20L30/31.3		

B14B 安装结构形式

B14B mounting constructions

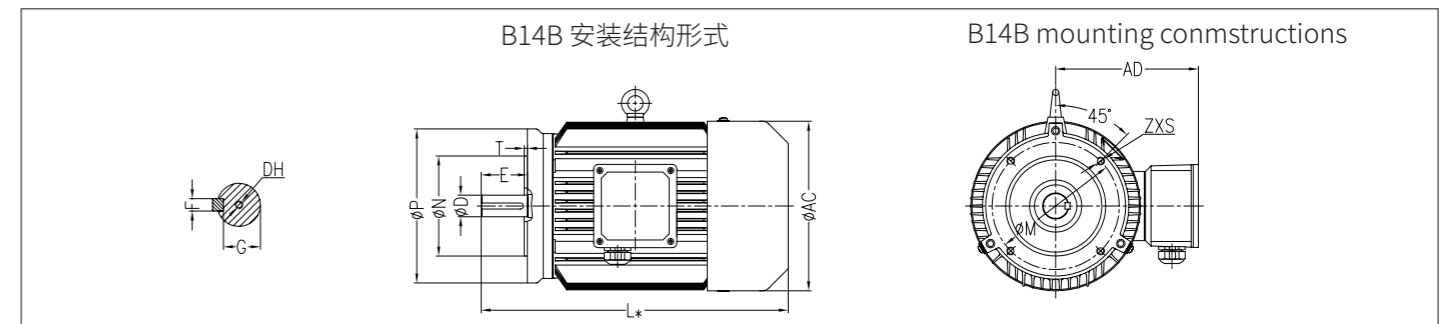

机座 Frame 号 size	极 No. of 数 poles	尺寸 (mm) Dimension (mm)														
		D	E	F	G	M	N	P	S	T	Z	AC	AD	DH		
071M	4、6	14	30	5	11	115	95	140	M8	3	4	139	130	CM5L10/8.8		
080M	4、6	19	40	6	15.5	130	110	160	M8	3.5	4	159	151	CM6L12/10.5		
090S	4、6	24	50	8	20	130	110	160	M8	3.5	4	176	158	CM8L12/13.2		
090L	4、6	24	50	8	20	130	110	160	M8	3.5	4	176	158	CM8L12/13.2		
100L	4、6	28	60	8	24	165	130	200	M10	4	4	199	171	CM10L15/16.3		
112M	4、6	28	60	8	24	165	130	200	M10	4	4	220	181	CM10L15/16.3		
132S	4、6	38	80	10	33	215	180	250	M12	4	4	259	203	CM12L20/19.8		
132M	4、6	38	80	10	33	215	180	250	M12	4	4	259	203	CM12L20/19.8		

MU马达
外形尺寸 (续)

MU motor dimensions
(continue)

MU马达长度尺寸和重量

MU motor length and weight

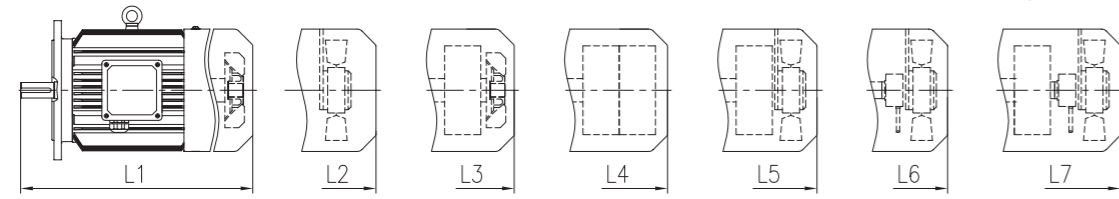

Self-fan cooling Forced-fan cooling Brake +Self-fan cooling Double brake Brake +Forced-fan cooling Encoder+ Forced-fan cooling Brake+ Encoder+ Forced-fan cooling

机座号 Frame size	4极 4-pole 功率 power (kW) (kW)	马达尺寸 Motor length L*(mm) L* (mm)						马达重量 Motor weight (kg)						
		L1	L2	L3	L5	L6	L7	M1	M2	M3	M5	M6	M7	
063M	0.12	215	270	250	305	/	/	7.5	8	9	9.5	/	/	
063M	0.18	215	270	250	305	/	/	8.5	9	10	10.5	/	/	
071M	0.25	244	289	284	339	339	379	9.5	10.5	11	12	11	13	
080M	0.37	301	346	361	411	411	456	15	16	19	20	16.5	21	
080M	0.55	301	346	361	411	411	456	16	17	20	21	17.5	22	
090S	0.75	334	379	389	439	439	489	20	21	24	25	21.5	26	
090L	1.1	359	379	414	439	439	489	22	23	26	27	23.5	28	
100L	1.5	409	449	484	524	524	579	31	32	39	40	33	41	
100L	2.2	409	449	484	524	524	579	34	35	42	43	36	44	
112M	3	472	522	547	597	597	652	55	57	63	64	58	65	
132S	4	503	553	583	628	628	683	75	77	87	89	78	90	
132M	5.5	541	591	621	666	666	721	78	80	89	91	81	92	
160M	7.5	640	680	740	770	770	820	128	130	149	151	131	152	
160L	11	675	710	770	800	800	850	160	162	181	183	163	184	
180M	15	706	736	816	841	841	886	198	200	230	232	201	234	
180L	18.5	754	784	864	889	889	934	218	220	250	252	221	254	
200L	22	797	802	912	917	917	962	279	280	329	330	281	332	
225S	30	869	899	984	1014	1014	1059	343	345	393	394	346	396	
225M	37	869	899	984	1014	1014	1059	365	367	415	416	368	418	
250M	45	964	979	1104	1114	1114	1169	467	469	572	573	470	575	
280S	55	1011	1041	1151	1186	1186	1231	627	629	732	734	630	736	
280M	75	1062	1092	1202	1237	1237	1282	650	652	755	757	653	759	
280M	90	1062	1092	1202	1237	1237	1282	720	722	825	827	723	829	

MU马达长度尺寸和重量

MU motor length and weight

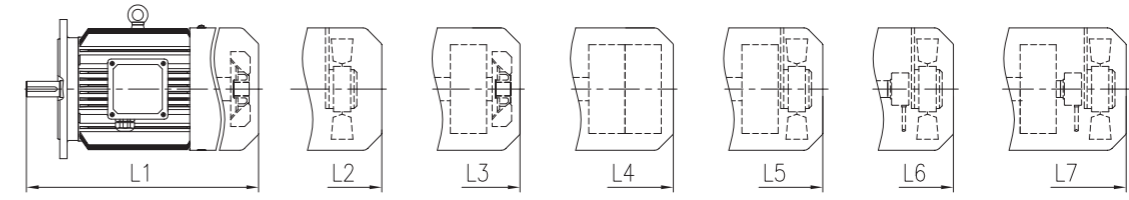

Self-fan cooling Forced-fan cooling Brake +Self-fan cooling Double brake Brake +Forced-fan cooling Encoder+ Forced-fan cooling Brake+ Encoder+ Forced-fan cooling

机座号 Frame size	6极 6-pole 功率 power (kW) (kW)	马达尺寸 Motor length L*(mm) L* (mm)						马达重量 Motor weight (kg)						
		L1	L2	L3	L5	L6	L7	M1	M2	M3	M5	M6	M7	
071M	0.18	244	289	284	339	339	379	11	12	12.5	13.5	12.5	14.5	
080M	0.25	301	346	361	411	411	456	15	16	19	20	16.5	21	
080M	0.37	301	346	361	411	411	456	17	18	21	22	18.5	23	
090S	0.55	334	379	389	439	439	489	20	21	24	25	21.5	26	
090L	0.75	359	404	414	464	464	514	25	26	29	30	26.5	31	
100L	1.1	409	449	484	524	524	579	30	32	38	39	33	40	
112M	1.5	472	522	547	579	579	652	56	57	65	65	58	66	
132S	2.2	503	553	583	628	628	683	77	79	88	90	80	91	
132M	3	503	553	583	628	628	683	68	70	79	81	71	82	
132M	4	541	591	621	666	666	721	87	89	98	100	90	101	
160M	5.5	645	685	740	775	775	825	129	131	150	151	132	152	
160L	7.5	675	710	770	800	800	850	161	163	182	183	164	184	
180L	11	706	736	816	841	841	886	159	161	183	184	162	186	
200L	15	797	802	912	917	917	962	228	230	278	279	231	281	
200L	18.5	797	802	912	917	917	962	258	260	308	309	261	311	
225M	22	869	899	984	1014	1014	1059	327	329	377	379	330	381	
250M	30	964	979	1104	1114	1114	1169	432	434	537	538	435	540	
280S	37	1011	1041	1151	1186	1186	1231	540	542	645	647	543	649	
280M	45	1062	1092	1202	1237	1237	1282	580	582	685	687	583	689	
280M	55	1062	1092	1202	1237	1237	1282	620	622	725	727	623	729	

12 马达尾部出轴和防雨罩尺寸

12 Dimensions of motor shaft projecting tail and rainproof cover

马达尾部出轴尺寸

Dimensions of motor shaft projecting tail

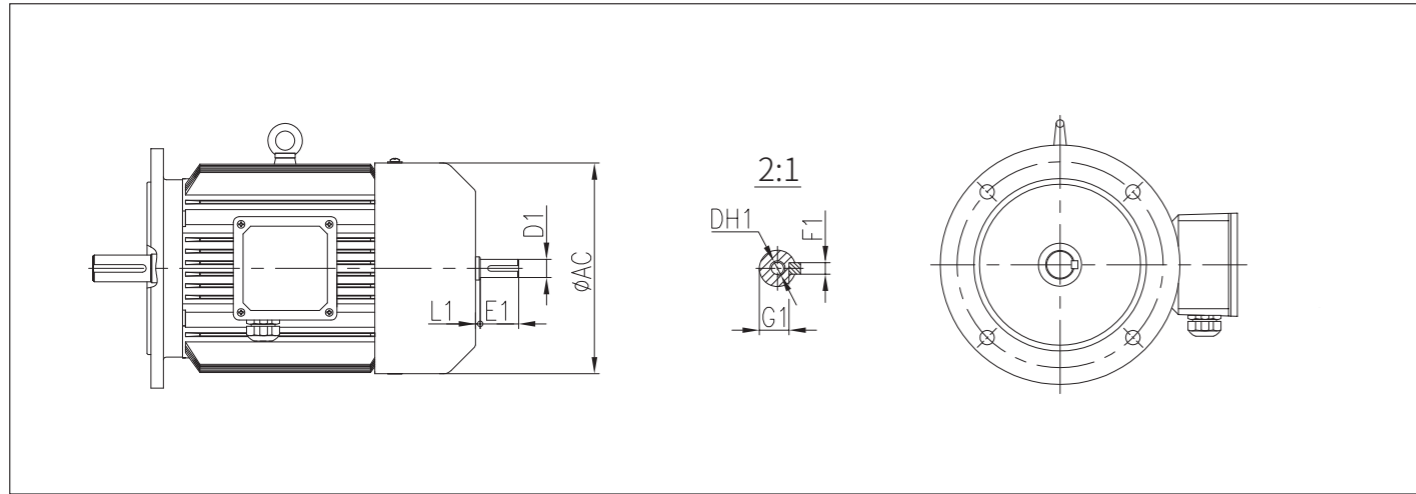

机座号 Frame size	尺寸 (mm)				Dimension (mm)		
	D1	E1	F1	G1	L1	DH1	AC
80	敬请垂询 Please inquire						
90							
100							
112							
132							
160							
180							
200							
225							
250							
280							

防雨罩尺寸

Dimensions of rainproof cover

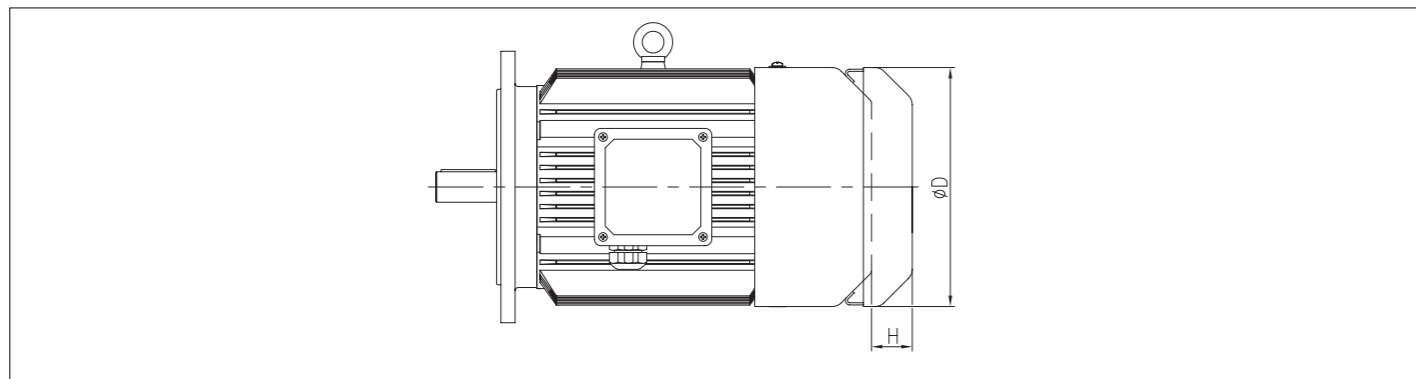

机座号 Frame size	H63	H71	H80	H90	H100	H112	H132	H160	H180	H200	H225	H250	H280
D	124	139	159	176	199	220	259	314	356	398	446	485	547
H	25	30	30	35	40	40	40	60	60	70	70	80	80

13 电气连接原理图

13 Electrical connection schematics

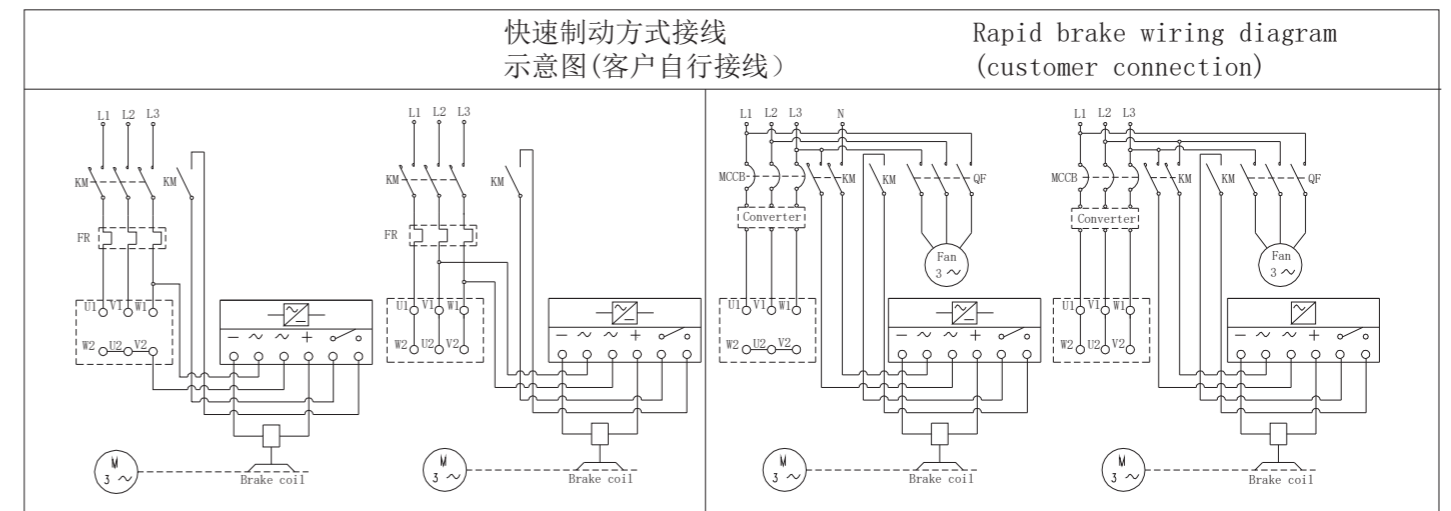
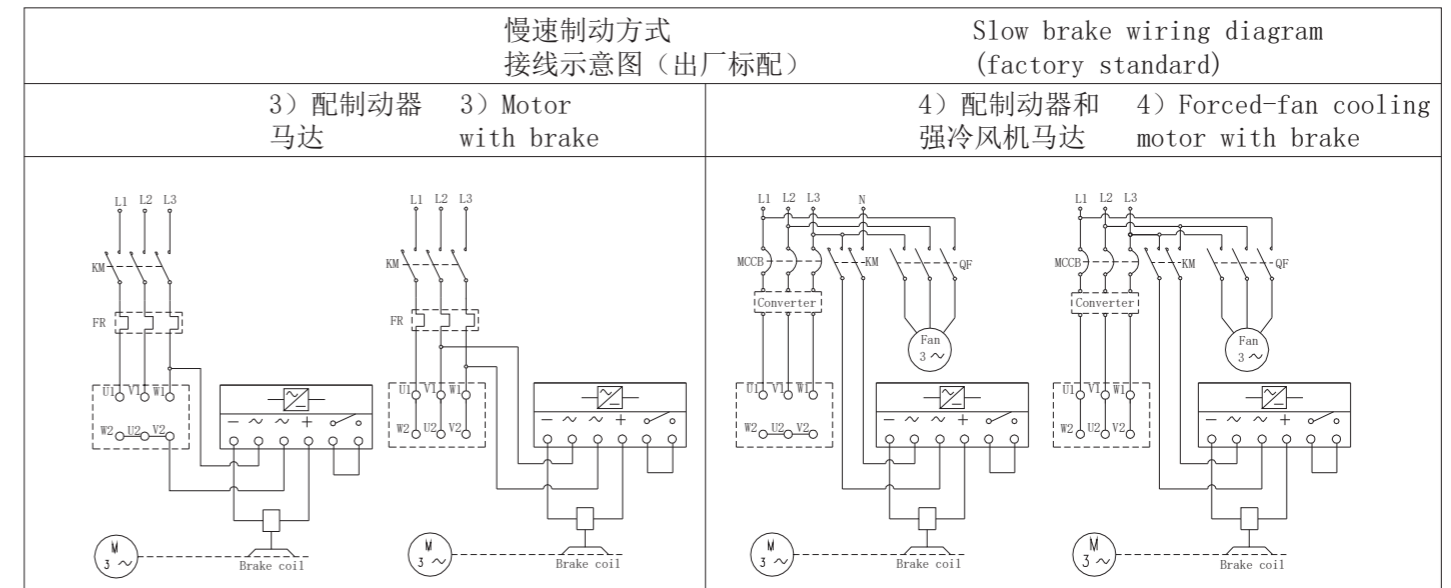
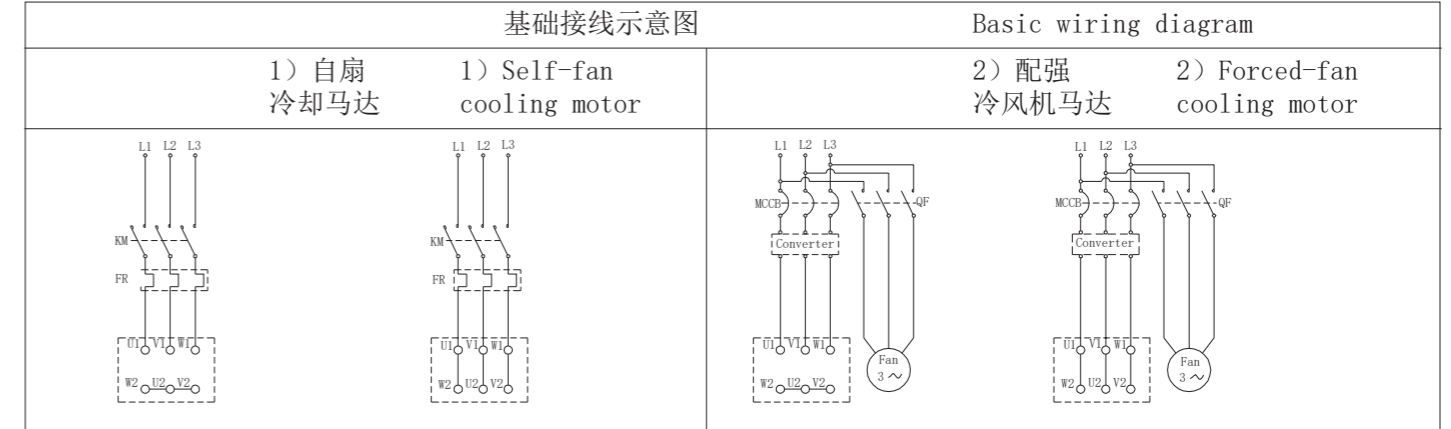

控制层 CONTROL

驱动层 DRIVE

马达层 MOTOR

MOTOR

齿轮层 GEAR

GEAR



X3010 PLC
EtherCAT&Modbus
24VDC



X3050 运动控制器
Motion Controller
EtherCAT&Modbus
24VDC

C/F/K/S-M
* . . . D
马达分布式变频驱动器
Integrated Gearmotor Drive

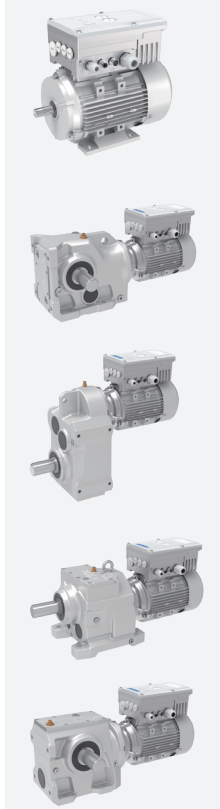

EtherCAT&Modbus
380~480VAC
0.25~3kW
i=4~355

AM 变频驱动器
Variable Frequency Drive



Modbus
380~480VAC
0.75~5.5kW

A1 变频驱动器
Variable Frequency Drive

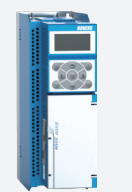

Modbus/CANopen/
PROFINET
380~480VAC
0.75~250kW

C/F/K/S/R
齿轮马达
Gearmotor



380~480VAC
0.09~200kW
i=1.25~500

MP/MU
三相交流异步马达
Asynchronous Motor



380~480VAC
0.09~90kW
960/1450r/min
1160/1750r/min

HB/BE/HK
齿轮箱
Gearbox



4.2~15775kW
i=5.6~450

P/PK
行星齿轮箱
Planetary Gearbox



0.4~14000kW
i=25~4000

PW
卷扬齿轮箱
Planetary Winch Gearbox



1~1810kW
i=13~940

PS
回转齿轮箱
Planetary Slewing Gearbox



1~1626kW
i=14~947

J/JB
升降机
Jack



0.35~22.63kW
i=5~34

T
转向箱
Spiral Bevel Gearbox



0.08~303kW
i=1:1~3:1

MX&AX
伺服马达&伺服驱动器
Permanent Magnet Servo Motor & Servo Drive



EtherCAT/
PROFINET
380~480VAC
0.28~14kW
1500/2000r/min
3000/4500r/min

C/F/K/S-MX & AX
齿轮伺服马达&伺服驱动器
Servo Gearmotor & Servo Drive

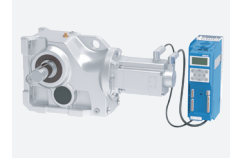

EtherCAT/
PROFINET
380~480VAC
0.28~14kW
i=1.25~315

PX-MX&AX
行星伺服马达&伺服驱动器
Planetary Precision Gear Servo Motor & Servo Drive

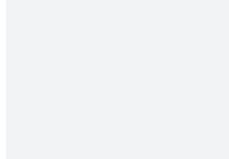
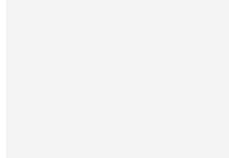

EtherCAT/
PROFINET
380~480VAC
0.38~14kW
i=3~100

PN-MN&AN
行星伺服马达&伺服驱动器
Planetary Precision Gear Servo Motor & Servo Drive

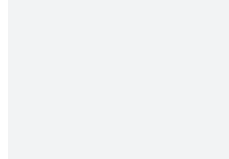

EtherCAT
PROFINET
380~480VAC
0.28~5.03kW
i=3~100

ME&AN
永磁同步伺服马达&伺服驱动器
Permanent Magnet Servo Motor & Servo Drive



EtherCAT/
PROFINET
200~240VAC
0.1kW~1.2kW

博能传动(沈阳)有限公司	BONENG TRANSMISSION(SHENYANG)CO.,LTD.
辽宁省沈阳市沈北新区 太平洋工业城A区A73-6号 电话: 024-31271571	No. A73-6, Area A, Pacific Industrial City, Shenbei New District, Shenyang, Liaoning Province, China TEL: 024-31271571
博能传动(天津)有限公司	BONENG TRANSMISSION(TIANJIN)CO.,LTD.
天津市北辰区双海道6号 宏鹏工业园7号车间 电话: 022-26929556	7th Workshop, Hongpeng Industrial Park, No. 6 Shuanghai Road, Beichen District, Tianjin City,China TEL: 022-26929556
博能传动(潍坊)有限公司	BONENG TRANSMISSION(WEIFANG)CO.,LTD.
山东省潍坊市安丘市经济开发区 汶水路与昆仑大街交叉口往北 100米路东1号车间 电话: 0536-2141166	1st Workshop, Economic Development Zone, Anqiu, Weifang City, Shandong Province, China TEL: 0536-2141166
博能传动(开封)有限公司	BONENG TRANSMISSION(KAIFENG)CO.,LTD.
河南省开封市宋城路四大街11号 海神机械院内五号厂房 电话: 0371-23335238	5th Workshop, Haishen Machinery, No.11, Fourth Street, Songcheng Road,New District, Kaifeng City, Henan Province, China TEL: 0371-23335238
博能传动(长沙)有限公司	BONENG TRANSMISSION(CHANGSHA)CO.,LTD.
湖南省长沙市望城经济开发区 普瑞大道1288号 电话: 0731-88386958	No. 1288 Puri Avenue, Wangcheng Economic Development Zone, Changsha City, Hunan Province, China TEL: 0731-88386958
博能传动设备(成都)有限公司	BONENG TRANSMISSION EQUIPMENT(CHENGDU) CO., LTD.
四川省成都市金牛区金牛坝路9号5栋 向荣中心A座7楼-703 电话: 028-87741100	703, 7th Floor, Block A, Xiangrong Center, Building 5, No. 9 Jinniuba Road, Jinniu District, Chengdu City, Sichuan Province, China TEL: 028-87741100
博能传动(肇庆)有限公司	BONENG TRANSMISSION(ZHAOQING)CO.,LTD.
广东省肇庆市鼎湖区肇庆新区 科创大道7号平谦国际现代产业园 一期A12北厂房 电话: 0757-86719757	No. 7 Science and Technology Innovation Avenue, Zhaoqing New Area, Dinghu District, Zhaoqing City, Guangdong Province, China TEL: 0757-86719757
博能传动(苏州)有限公司	BONENG TRANSMISSION(SUZHOU)CO.,LTD.
江苏省苏州市相城区如元路100号 电话: 0512-66189662	No. 100, Ruyuan Road, Xiangcheng District, Suzhou, Jiangsu Province, China TEL: 0512-66189662

博能传动(美国)有限公司	BONENG TRANSMISSION(USA)LLC.
1250 E 222nd Euclid, OH 44117, United Staes TEL: 1-216-618-0138 TEL: 1-216-618-0496 TEL: 1-216-618-3099	1250 E 222nd Euclid, OH 44117, United Staes TEL: 1-216-618-0138 TEL: 1-216-618-0496 TEL: 1-216-618-3099
博能传动(印度)有限公司	BONENG TRANSMISSION(INDIA)PVT.LTD
Plot No. E-10/3, MIDC sinnar (Malegaon) Industrial Area, Nashik, 422123, Maharashtra, India. TEL:+91-11- 4507 6293 (DELHI) TEL:+91-22-2781 3385 (MUMBAI)	Plot No. E-10/3, MIDC sinnar (Malegaon) Industrial Area, Nashik, 422123, Maharashtra, India. TEL:+91-11- 4507 6293 (DELHI) TEL:+91-22-2781 3385 (MUMBAI)