

BONENG

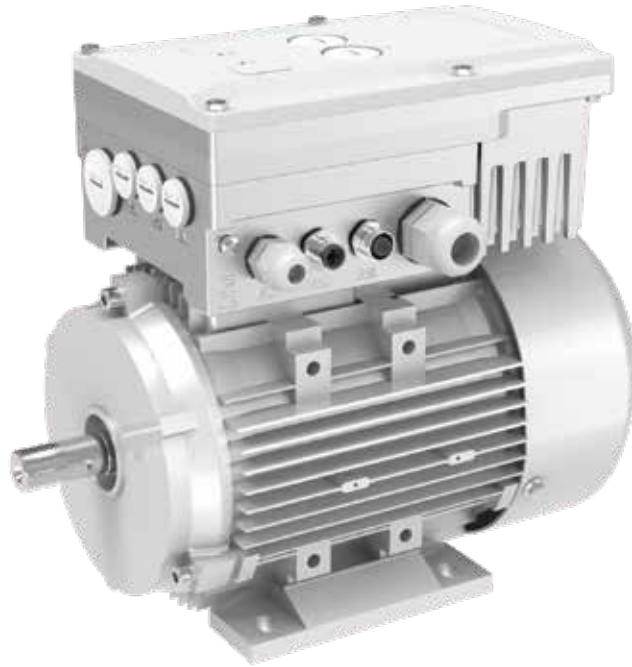

MP马达变频驱动一体机
(0.25kW~3kW)

**MP Inverter-optimised
AC Motor**
(0.25kW~3kW)

Edit date 03/2024
Selection Catalogue: C05.0049

Boneng Transmission

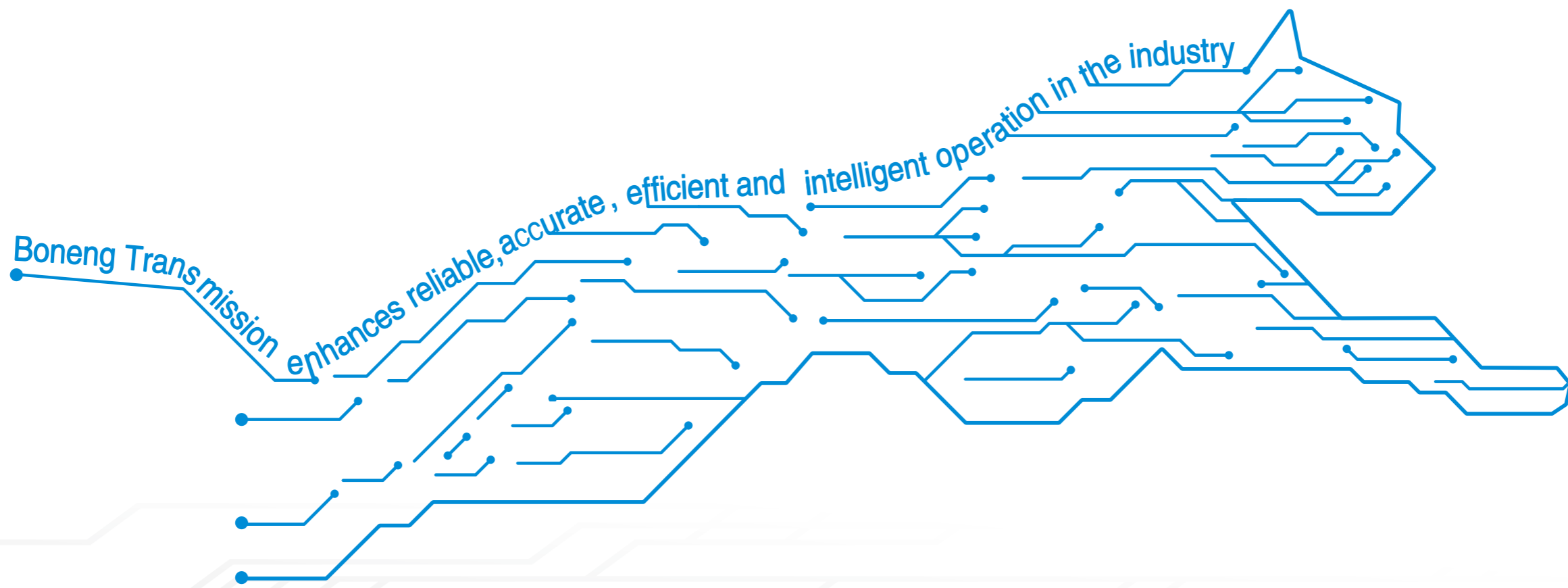

控制器/驱动器/马达/
齿轮马达/齿轮箱

Controller/ Drive/ Motor/
Gearmotor/ Gearbox

目 录

CONTENTS

1. 马达变频驱动一体机 概述	01	1. Overview of Inverter-optimised AC Motor	01
2. 马达变频驱动一体机 产品特性	01	2. Features of Inverter-optimised AC Motor	01
3. 马达变频驱动一体机 机械特性	05	3. Mechanical char- acteristics of Invert- er-optimised AC Motor	05
4. 马达变频驱动一体机 优势特点	05	4. Advantages of Inverter-optimised AC Motor	05
5. 马达变频驱动一体机 型号表示方法	07	5. Type designation of Inverter-opti- mised AC Motor	07
6. 马达变频驱动一体机 操作面板OP25 (选配) ..	08	6. Operation panel OP25 (optional) of Inverter-optimised AC Motor	08
7. 马达变频驱动一体机 选型技术参数	09	7. Technical data of Inverter-optimised AC Motor	09
8. 马达变频驱动一体机 外形尺寸	10	8. Dimensions of Inverter-optimised AC Motor	10

1 马达变频驱动一体机概述

马达变频驱动一体机是基于分布式应用的马达驱动器一体式产品, 搭配全封闭自扇冷却三相交流异步马达, 设计生产符合ISO、IEC、GB 等相关标准的要求。适用于连续工作制(S1)、恒转速或一定速度范围内的变频调速应用, 同时

也满足大部分断续工作方式(S2-S10)。该一体机系统专门针对输送带、分拣系统、行李和货运输送系统、仓库和配送物流、邮件分拣以及包裹配送等应用中的节能和成本效益水平运动进行了优化。可广泛应用于多机水平输送等行业, 以及对防护等级有较高要求的电气传动场合。

2 马达变频驱动一体机产品特性

2.1. 技术特性

- ◆ 机座材料: 压铸铝;
- ◆ 马达颜色: 银色RAL9006
- ◆ 额定功率: 0.25kW~3kW;
- ◆ 马达极数: 4;
- ◆ 马达效率: 达到GB18613-2020标准能效等级3级, 且满足 IEC 60034-30标准中的IE3效率等级;
- ◆ 标准安装结构类型: IMB3、IMB5、IMB14B等;
- ◆ 马达防护等级: 防护等级为IP55;
- ◆ 马达绝缘等级: 绝缘系统按155°C (F) 温度等级设计, 按130°C (B) 温度等级考核;
- ◆ 马达冷却方式: 马达标准冷却方式为IC411自扇冷却。
- ◆ 支持SVC(开环矢量)控制、VF控制
- ◆ 可实现速度控制
- ◆ 支持Modbus通讯、EtherCAT通讯
- ◆ 支持本地上位机连接

2.2. 运行环境

- ◆ 高度不超过海拔1000m;
- ◆ 允许的环境温度在-20°C~40°C;
- ◆ 所允许的相对湿度:
 - 20°C ≤ T ≤ 20°C: 100%
 - 20°C < T ≤ 30°C: 95%
 - 30°C < T ≤ 40°C: 55%

1 Overview of Inverter-optimised AC Motor

The Inverter-optimised AC Motor is based on distributed application and equipped with totally enclosed fan cooled three-phase asynchronous motor. Its design and production meet the requirements of ISO, IEC, GB and other related standards. The integrated machine is applicable for continuous running duty (S1), constant speed and variable frequency speed control within a specific speed range. Also, it can meet most short-time duty (S2-S10).

The Inverter-optimised AC Motor system is optimized for energy conservation and cost performance in the field of conveyor belt, automatic sorting systems, baggage and cargo system, warehouse and distribution logistics, mail sorting, parcel delivery and other objects. It is widely used in multi-machine horizontal conveying and other industries, as well as electrical transmission occasions with higher requirements for protection levels.

2 Features of Inverter-optimised AC Motor

2.1. Technical characteristics

- ◆ Frame material: die-casting aluminum;
- ◆ Motor color: silver RAL9006;
- ◆ Rated power: 0.25kW~3kW;
- ◆ Poles of motor: 4;
- ◆ Motor efficiency: meet Grade 3 according to GB18613-2020 and IE3 according to IEC 60034-30
- ◆ Standard mounting structure: IMB3, IMB5, IMB14B, etc.
- ◆ Degree of protection : IP55
- ◆ Insulation class: the insulation system is designed for temperature class 155°C(F) and checked by temperature class 130°C(B);
- ◆ Cooling method: self-ventilated(IC411) as standard;
- ◆ Support SVC (open-loop vector) control and VF control;
- ◆ Realize speed control;
- ◆ Support Modbus communication and EtherCAT communication;
- ◆ Support local upper computer connection.

2.2. Operating environment

- ◆ Altitude shall not exceed 1000m above seal-level;
- ◆ Allowed temperature between -20°C and 40°C;
- ◆ Permitted relative humidity:
 - 20°C ≤ T ≤ 20°C: 100%
 - 20°C < T ≤ 30°C: 95%
 - 30°C < T ≤ 40°C: 55%

2.3.驱动器规格参数

2.3 Drive specification parameters

		端口参数		Port parameters	
输出电源	Output power supply	外接24V电源	External 24V power supply	24VDC±10%, 最大40mA	24VDC±10%, max. 40mA
		外接10V电源	External 10V power supply	+10V-GND, 最大10mA	+10V-GND, max. 10mA
数字量输入	Digital input	4通道共COM输入	4 channels COM input	DI0~DI3, 光耦隔离, 支持双向输入	DI0~DI3, opto~isolator, support bidirectional input
				输入电压 12VDC~30VDC	Input voltage: 12VDC~30VDC
模拟量输入	Analog input	1通道输入	1 channel input	电压型: DC0~10V	Voltage type: DC0~10V
				精度1%	Precision: 1%
LED指示灯	LED indicator	两个双色指示	2 two-color indicator lights	运行、故障、通信状态指示	Indication of running, failure and communication status
通讯端口	Communication port	RS485通讯或以太网通讯	RS485 communication or EtherCAT communication	Modbus RTU 格兰头借口	ModBus RTU cable gland port
				EtherCAT 航空插头	EtherCAT aviation plug
		PC通讯街口	PC communication port	RS485通讯, 特制端口	RS485 communication, Special purpose port
				支持PC上位机调试以及软件更新	Support PC upper computer debugging and software update

功率参数 (通用参数)		Power parameter (common parameters)	
输入电压	Input voltage	380~480V 3AC±10%	380~480V 3AC±10%
输入频率	Input frequency	47~63Hz	47~63Hz
输出频率	Output frequency	0~300Hz 50Hz, <50Hz参 见阵容曲线	0~300Hz (see the derating curve when frequency less than 50Hz)
载波频率	Carrier frequency	4kHz (标准)	4kHz (standard)
功率因素	Power factor	0.95	0.95
控制器效率	Efficiency of controller	95~97%	95~97%
过载能力	Overload capability	1.2倍额定输 出电流 1min, 1.5倍 额定输出电 流3sec, 周期 10min	1.2 times rated output current for 1min, 1.5 times rated output current for 3 s within a cycle time of 10min
电磁兼容	Electromagnetic compatibility	可选符合 EN55011标 准的A级和B 级滤波器	Class A and B filters are available according to EN 55011
防护等级	Protection grade	IP55	IP55
工作温度	Operating temperature	-20~+40°C不 降容, > 40~60°C, 参 见阵容曲线	-20~+40°C: no derating; 40~60°C: see the derating curve
标准SCCR	Standard SCCR	10kA	10kA
保护功能	Defensive function	欠电压	Under voltage
		过电压	Over voltage
		过载	Overload
		短路	Short circuit
		电机失速保护	Motor stall protection
		电机过载	Motor overload
		变频器温度	Inverter over temperature

2.4.驱动器特性曲线

2.4.Drive characteristic curve

降容数据·环境温度

Derating data · environment temperature

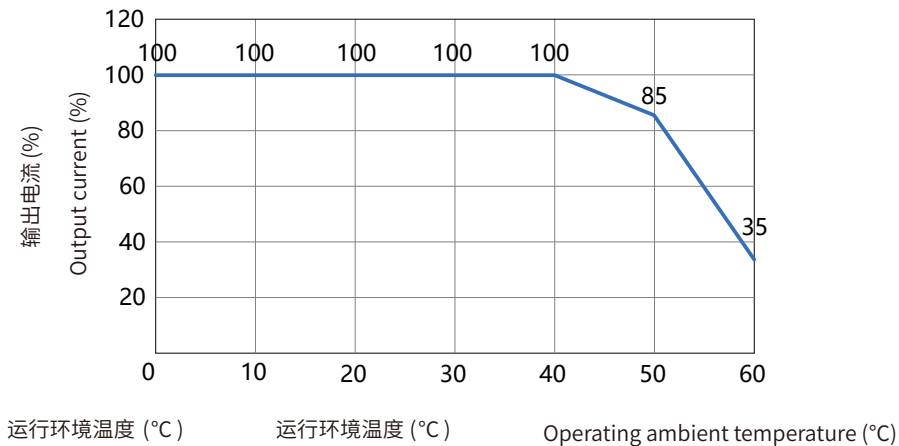

降容数据·海拔高度

Derating data · altitude

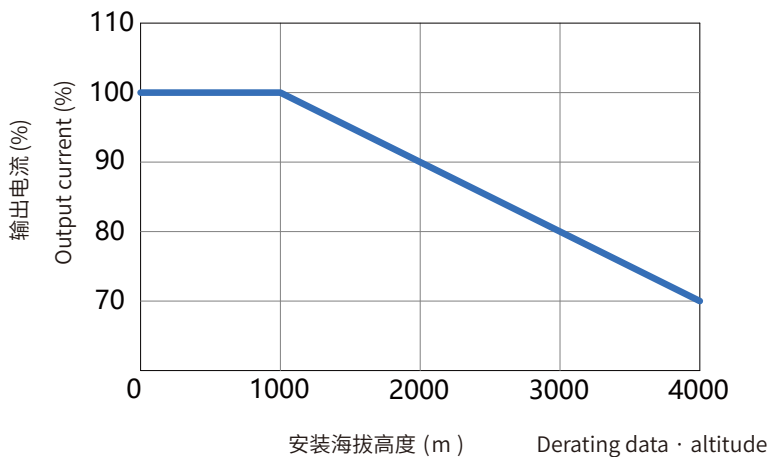

降容数据·输出频率

Derating data · output frequency

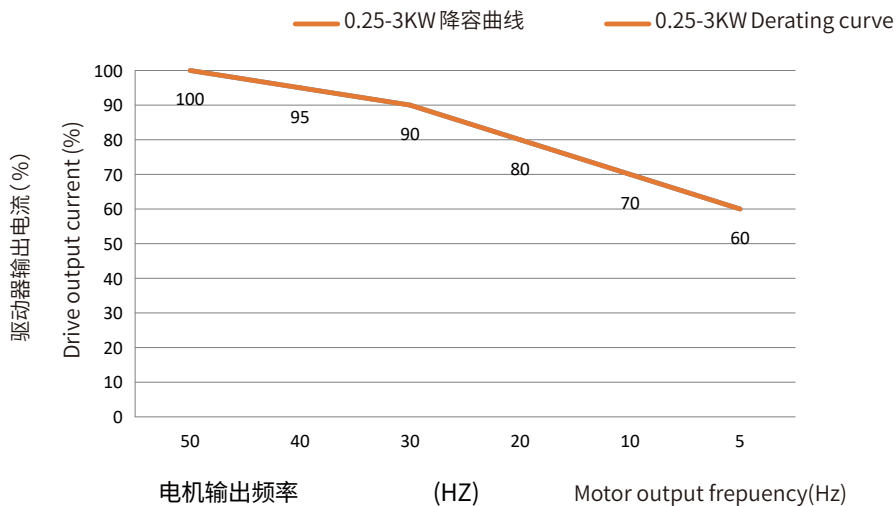

3 马达变频驱动 一体机机械特性

3 Mechanical characteristics of Inverter-optimised AC Motor

安装结构型式

Type of construction

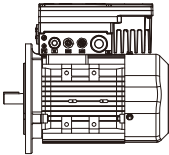
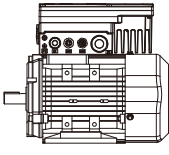
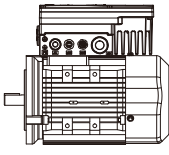
基本结构型式 Basic construction type	机座端盖有法兰, 机座无底脚 Cover with flange, frame without feet	机座有底脚, 端盖无法兰 Cover without flange, frame with feet	机座端盖有小法兰, 机座无底脚 Cover with small flange, frame without feet
Frame	71~100	71~100	71~100
Code	B5	B3	B14B
Diagram			

4. 马达变频驱动 一体机优势特点

4. Advantages of Inverter-optimised AC Motor

(1) 用户友好

(1) User-friendliness

安装灵活 Flexible installation	具备多方向进线、多方位安装, 匹配客户环境需求	With multi-directional cable entry and multi-direction installation, it meet the customer environmental requirements
参数拷贝 Parameter copy	调试一台驱动器, 通过PC软件拷贝到其他驱动器	Debug a drive and copy it to another drive using PC software
参数分组 Grouping of parameters	功能码合理分组, 参数简单直观, 方便理解	Function code is grouped reasonably and parameters are simple and intuitive for understanding
支持Boneng-Drivesoft软件 Support BonengDrivesoft software	参数显示及修改, 虚拟示波器, 已修改参数等功能方便调试	Parameter display and modification, virtual oscilloscope, modified parameters and other functions are convenient for debugging
选配电位器 Optional potentiometer	带电位器旋钮, 实现无极调速	Stepless speed regulation is achieved with potential knob to achieve

(2) 品质可靠

(2) Reliable quality

高质量电子元件/电容器 High quality electronic components/capacitor	使用寿命更长 Longer service life
所有变频器出厂前进行满负荷测试 All frequency converters are tested at full load before leaving the factory	可靠性高 high reliability
完善的驱动器保护功能 Complete drive protection function	平均无故障时间长 Longer mean time between failures
带涂层电路板, 防潮、防腐蚀外壳 Coated circuit board, damp and corrosion proof housing	适应更恶劣环境 Adapt to the harsher environment

(3) 性能卓越

(3) Superior performance

过程比例积分 (PID) 控制器	Process proportional integral controller (PID)	无需外部控制器	No external controller required
自动识别电机模型	Automatic identification of motor models	发挥电机的全部潜能	Develop the full potential of the motor
随载随速	Following load and speed	轻载高速 重载限速 提升工作效率	Light load with high speed, heavy load with limited speed, there by improving work efficiency
跟踪启动	Trace startup	避免启动冲击	Avoid start-up shocks
支持参数互联	Support parameter interconnection	参数可互联到P组, 可实现启停来源, 速度来源等选择来自P组参数, 极其灵活	The parameters can be interconnected to the P group and realize the parameter selection from the P group such as the start and stop source, the speed source, etc., which is extremely flexible
支持自由功能块	Support free function modules	支持逻辑, 算术运算, 延时, 数据选择, 适用特殊工况参数设置	Support logic, arithmetic operation, delay, data selection and special working conditions parameter setting

(4) 成本节约

由于无需机柜和长距离电机电缆, 可以节省成本, 且系统设计外观漂亮。

(4) Cost saving

Without cabinets and long-distance motor cables, costs are saved and the system design looks great.

5 马达变频驱动一体机型号表示方法

5 Type designation of Inverter-optimised AC Motor

MP100M4B22 H L 2 -D 0 MB 0 -1 1 1

进线孔位置²⁾

1/3

接线盒位置²⁾

1/2/3/4

安装方位¹⁾

1/2/3/4/5/6

一体机防护等级

0=IP55
1=IP55+防雨罩

通讯协议

MB=Modbus RTU
EC=EtherCAT

调速旋钮³⁾

0=无调速旋钮
1=有调速旋钮

驱动器

D=分布式

频率/电压代号

2=47~63Hz/380~480V

机座材质

L=铝机座

安装形式

H=B3底脚安装
F=B5法兰安装
S=B14B法兰安装

Cable entry location²⁾

1/3

Terminal box location²⁾

1/2/3/4

Mounting position¹⁾

1/2/3/4/5/6

Protection degree

0=IP55
1=IP55+Rain cover

Communication protocol

MB=Modbus RTU
EC=EtherCAT

Speed control knob³⁾

0=No speed control knob
1=Speed control knob

Drive

D=Distributed

Code of voltage and frequency

2=47~63Hz/380~480V

Cast-aluminum frame

L=Aluminum

Construction type

H=B3 foot-mounted
F=B5 flange-mounted
S=B14B small flange-mounted

功率(kW)	MP=IE3 三相交流异步马达4极规格
Power(kw)	MP=IE3 4-pole three-phase asynchronous motor
0.25	MP071M4 A25..
0.37	MP071M4 A37..
0.55	MP080M4 A55..
0.75	MP080M4 A75..
1.1	MP090S4 B11..
1.5	MP090M4 B15..
2.2	MP100M4 B22..
3	MP100M4 B30..

注1) 安装方位

Note 1: mounting position

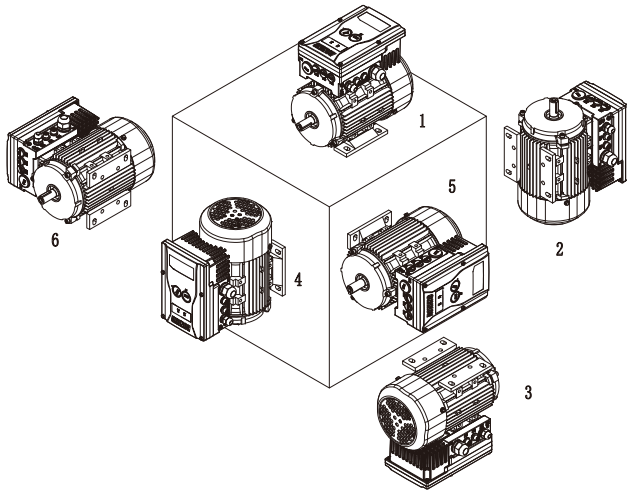

注2) 接线和进线位置 (视角: 安装方位 1 马达尾部)

Note 2: position of cable connection and entry (view angle: motor tail of mounting position 1)

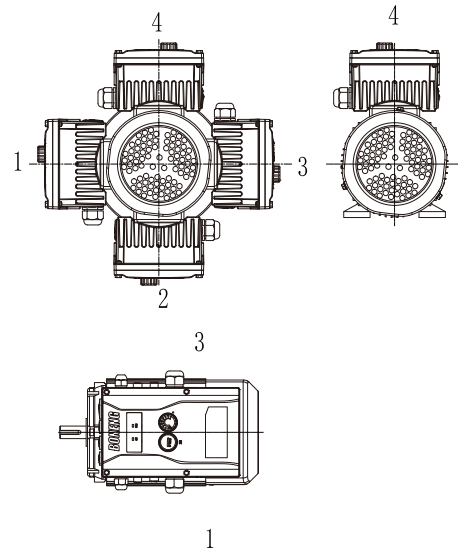

注3) 选配的旋钮的机型, 需注意安装方位, 接线盒位置的的组合。建议整机安装后, 旋钮朝上方或者侧方, 并预留 10mm 旋钮空间。

Note 3: Machine with optional knobs need to pay attention to the combination of installation direction and terminal box location. It is recommended that after the whole machine is installed, the knob is facing up or to the side and 10mm knob space is reserved.

6 马达变频驱动一体机 操作面板OP25 (选配)

6 Operation panel OP25 (optional) of Inverter-optimised AC Motor

操作面板OP25用于驱动器的调试、运行监控以及输入参数的设置。LCD屏可以显示四行, 每行最多8个汉字或者16个字母。通过专用转接线连接至一体机接口, 此一体机接口还可以通过USB转485线连接PC上位机。为方便参数设置, 建议每个使用现场需要至少选配一套本地调试组件(含OP25与转接线)。

订货型号: AD-OP25

Operation panel PO25 is used for drive debugging, operation monitoring and input parameter setting. The LCD screen can display four lines and each line contains up to 8 Chinese characters or 16 letters. Through a dedicated conversion cable, the panel can be connected the Inverter-optimised AC Motor interface which can also be connected to the PC host computer through the USB to 485 cable. To facilitate parameter setting, it is recommended to have at least one set of local commissioning components for each use site (includes OP25 and adapter cable). Order type: AD-OP25

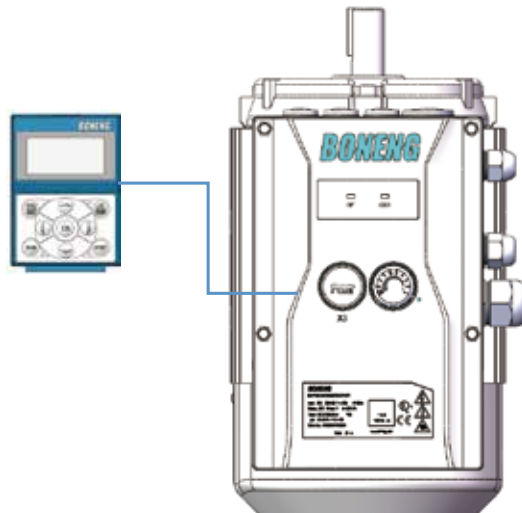

7 马达变频驱动一体机技术参数

MP马达变频驱动一体机技术参数 (IE3能效)

7 Technical data of Inverter-optimised AC Motor

Technical data of MP Inverter-optimised AC Motor (IE3 efficiency)

机座号	额定功率 (kW)	额定电压 (V)	额定频率 (Hz)	额定转速 (r/min)	额定转矩 (N.m)	马达能效等级	效率 (%)	功率因数 (COS ϕ)	额定电流 (A)	空载噪声 (dB)	转动惯量 (Kg.m ²)	驱动器额定输入电流 (A)	驱动器额定输出电流 (A)	通讯方式
Frame size	Motor rated power (kW)	Motor rated voltage (V)	Motor rated frequency (Hz)	Motor rated speed (r/min)	Motor rated torque (N.m)	Motor energy efficiency	Efficiency (%)	Motor power factor (COS ϕ)	Motor rated current (A)	No-load noise (dB)	Motor moment of inertia (Kg.m ²)	Drive rated input current (A)	Drive rated output current (A)	Communication mode
071M	0.25	400	50	1380	1.7	IE3	73.5	0.71	0.7	53	0.001	2.9	2.2	MB/EC
071M	0.37	400	50	1385	2.6	IE3	77.3	0.72	1	53	0.001	2.9	2.2	MB/EC
080M	0.55	400	50	1430	3.7	IE3	80.8	0.73	1.4	56	0.002	2.9	2.2	MB/EC
080M	0.75	400	50	1430	5	IE3	82.5	0.75	1.8	56	0.002	2.9	2.2	MB/EC
090S	1.1	400	50	1435	7.3	IE3	84.1	0.76	2.5	59	0.004	5.5	4.1	MB/EC
090M	1.5	400	50	1435	10	IE3	85.3	0.77	3.3	59	0.004	5.5	4.1	MB/EC
100M	2.2	400	50	1455	14.4	IE3	86.7	0.79	4.7	64	0.009	10.1	7.7	MB/EC
100M	3	400	50	1455	19.7	IE3	87.7	0.79	6.3	64	0.011	10.1	7.7	MB/EC

8 马达变频驱动一体机外形尺寸

8 Dimensions of Inverter-optimised AC Motor

MP马达选型尺寸参数 (IE3能效)

Dimensions of MP motor (IE3 efficiency)

B3

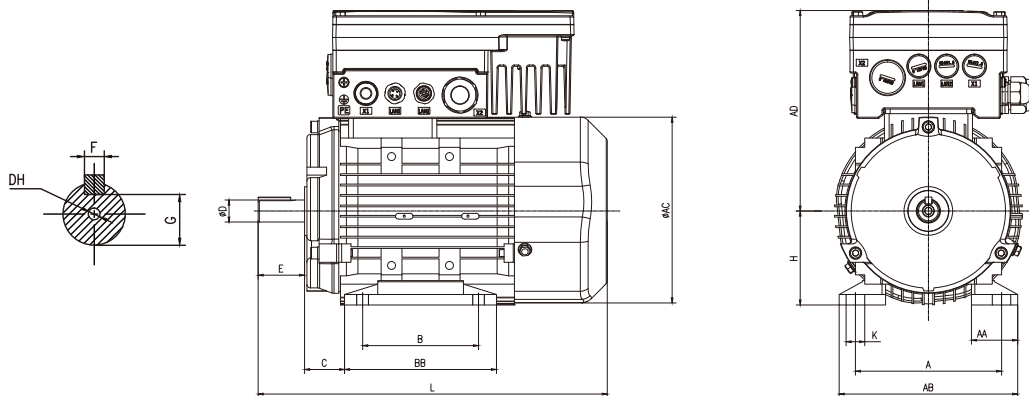

机座Frame 号 size	极数Poles	功率Power (kW)	尺寸(mm) Dimensions(mm)																重量Weight (kg) (kg)
			A	B	C	D	E	F	G	H	K	AA	AB	AC	AD	BB	DH	L	
071M	4	0.25	112	90	45	14	30	5	11	71	8	39	141	139	151.5	115	CM5L10/8.8	244	10
071M	4	0.37	112	90	45	14	30	5	11	71	8	39	141	139	151.5	115	CM5L10/8.8	244	11
080M	4	0.55	125	100	50	19	40	6	15.5	80	10	40	166	159	173	132	CM6L12/10.5	301	16
080M	4	0.75	125	100	50	19	40	6	15.5	80	10	40	166	159	173	132	CM6L12/10.5	301	17
090S	4	1.1	140	100	56	24	50	8	20	90	10	44	180	176	180	160	CM8L12/13.2	334	22
090M	4	1.5	140	125	56	24	50	8	20	90	10	44	180	176	180	160	CM8L12/13.2	359	24
100M	4	2.2	160	140	63	28	60	8	24	100	12	48	205	199	193	176	CM10L15/16.3	409	33
100M	4	3	160	140	63	28	60	8	24	100	12	48	205	199	193	176	CM10L15/16.3	409	37

B5

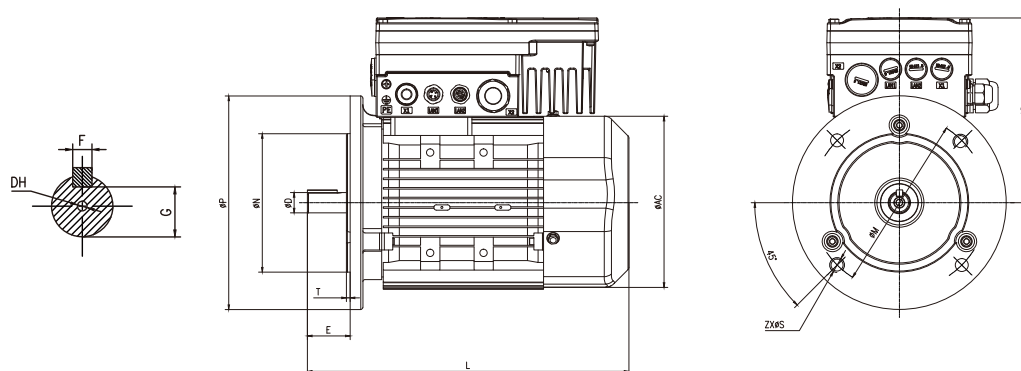

机座 Frame 号 size	极数 Poles	功率 Power (kW)	尺寸(mm) Dimensions(mm)														重量 Weight (kg)
			D	E	F	G	M	N	P	S	T	Z	AC	AD	DH	L	
071M	4	0.25	14	30	5	11	130	110	160	10	3	4	139	151.5	CM5L10/8.8	244	10
071M	4	0.37	14	30	5	11	130	110	160	10	3	4	139	151.5	CM5L10/8.8	244	11
080M	4	0.55	19	40	6	15.5	165	130	200	12	3.5	4	159	173	CM6L12/10.5	301	16
080M	4	0.75	19	40	6	15.5	165	130	200	12	3.5	4	159	173	CM6L12/10.5	301	17
090S	4	1.1	24	50	8	20	165	130	200	12	3.5	4	176	180	CM8L12/13.2	334	22
090M	4	1.5	24	50	8	20	165	130	200	12	3.5	4	176	180	CM8L12/13.2	359	24
100M	4	2.2	28	60	8	24	215	180	250	14.5	4	4	199	193	CM10L15/16.3	409	33
100M	4	3	28	60	8	24	215	180	250	14.5	4	4	199	193	CM10L15/16.3	409	37

B14B

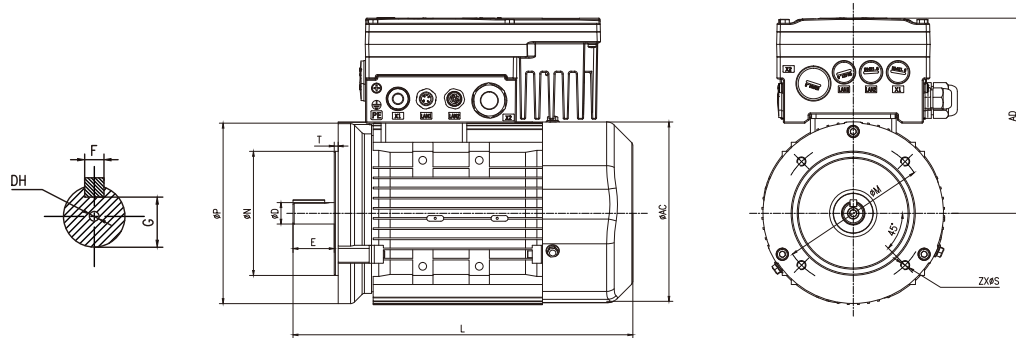

机座 Frame 号 size	极数 Poles	功率 Power (kW)	尺寸(mm) Dimensions(mm)														重量 Weight (kg)	
			D	E	F	G	M	N	P	S	T	Z	AC	AD	DH	L		
071M	4	0.25	14	30	5	11	115	95	140	M8	3	4	139	151.5	CM5L10/8.8	244	10	
071M	4	0.37	14	30	5	11	115	95	140	M8	3	4	139	151.5	CM5L10/8.8	244	11	
080M	4	0.55	19	40	6	15.5	130	110	160	M8	3.5	4	159	173	CM6L12/10.5	301	16	
080M	4	0.75	19	40	6	15.5	130	110	160	M8	3.5	4	159	173	CM6L12/10.5	301	17	
090S	4	1.1	24	50	8	20	130	110	160	M8	3.5	4	176	180	CM8L12/13.2	334	22	
090M	4	1.5	24	50	8	20	130	110	160	M8	3.5	4	176	180	CM8L12/13.2	359	24	
100M	4	2.2	28	60	8	24	165	130	200	M10	4	4	199	193	CM10L15/16.3	409	33	
100M	4	3	28	60	8	24	165	130	200	M10	4	4	199	193	CM10L15/16.3	409	37	

博能产品集成图

Boneng Product Integration Diagram

CONTROL
控制层

DRIVE
驱动层

MOTOR
马达层

GEAR
齿轮层

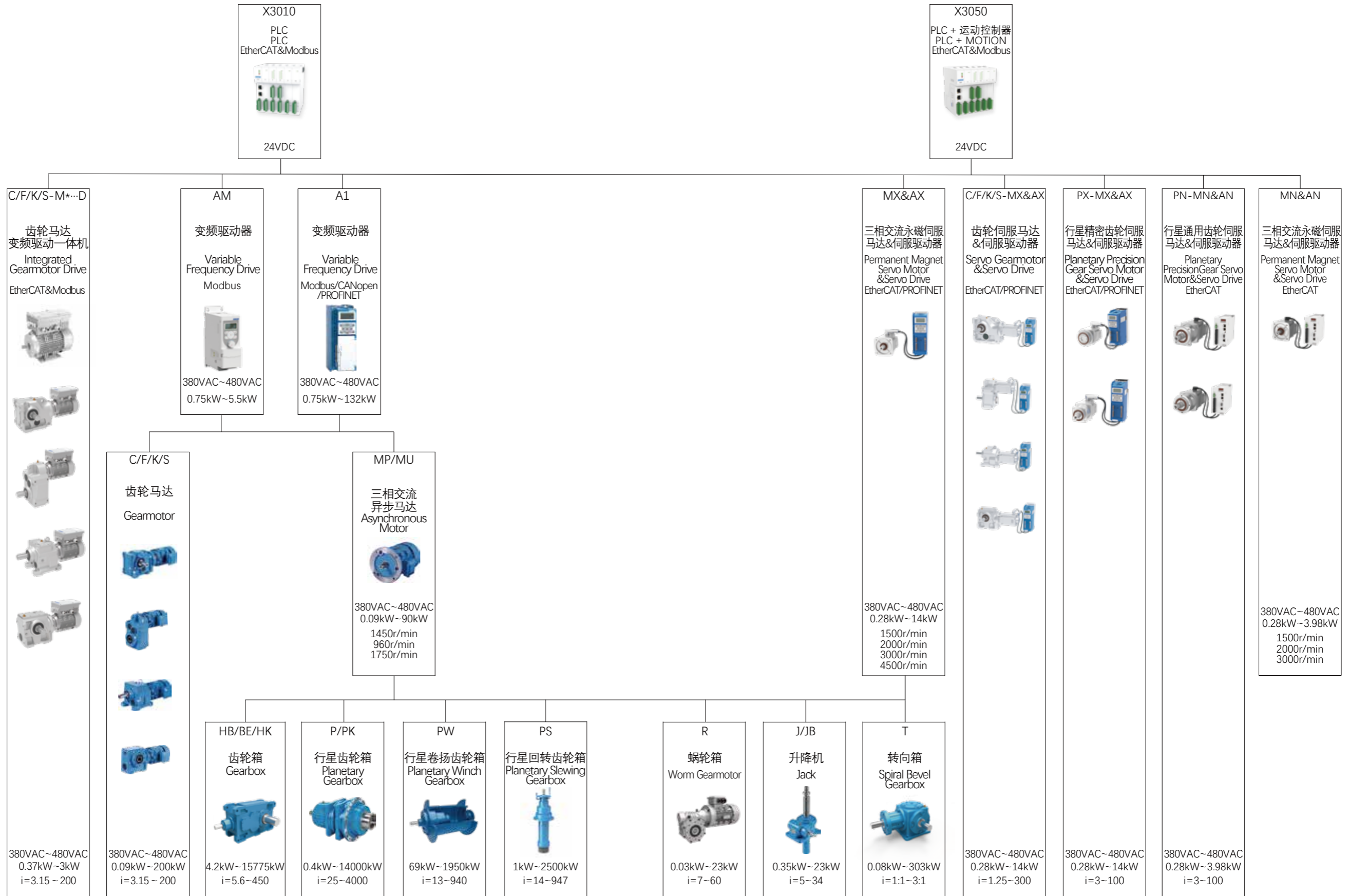

博能传动(沈阳)有限公司	BONENG TRANSMISSION(SHENYANG)CO.,LTD.
沈阳市沈北新区 太平洋工业城A区A73-6号 电话: 024-31271571	No. A73-6, Area A, Pacific Industrial City, Shenbei New District, Shenyang, Liaoning Province, China TEL: 024-31271571

博能传动(天津)有限公司	BONENG TRANSMISSION(TIANJIN)CO.,LTD.
天津市北辰区双海道6号 宏鹏工业园7号车间 电话: 022-26929556	7th Workshop, Hongpeng Industrial Park, No. 6 Shuanghai Road, Beichen District, Tianjin City,China TEL: 022-26929556

博能传动(潍坊)有限公司	BONENG TRANSMISSION(WEIFANG)CO.,LTD.
山东省潍坊市安丘市经济开发区 汶水路与昆仑大街交叉口往北 100米路东1号车间 电话: 0536-2141166	1st Workshop, Economic Development Zone, Anqiu, Weifang City, Shandong Province, China TEL: 0536-2141166

博能传动(开封)有限公司	BONENG TRANSMISSION(KAIFENG)CO.,LTD.
河南省开封市宋城路四大街11号 海神机械院内五号厂房 电话: 0371-23335238	5th Workshop, Haishen Machinery, No.11, Fourth Street, Songcheng Road,New District, Kaifeng City, Henan Province, China TEL: 0371-23335238

博能传动(长沙)有限公司	BONENG TRANSMISSION(CHANGSHA)CO.,LTD.
湖南省长沙市望城经济开发区 普瑞大道1288号 电话: 0731-88386958	No. 1288 Puri Avenue, Wangcheng Economic Development Zone, Changsha City, Hunan Province, China TEL: 0731-88386958

博能传动(苏州)有限公司	BONENG TRANSMISSION(SUZHOU)CO.,LTD.
江苏省苏州市相城区如元路100号 电话: 0512-66189662	No. 100, Ruyuan Road, Xiangcheng District, Suzhou, Jiangsu Province, China TEL: 0512-66189662

博能传动(美国)有限公司	BONENG TRANSMISSION(USA)LLC.
1250 E 222nd Euclid, OH 44117, United Staes TEL: 1-216-618-3099 TEL: 1-216-618-0138	1250 E 222nd Euclid, OH 44117, United Staes TEL: 1-216-618-3099 TEL: 1-216-618-0138

博能传动(印度)有限公司	BONENG TRANSMISSION(INDIA)PVT.LTD
Plot No. E-10/3, MIDC sinnar (Malegaon) Industrial Area, Nashik, 422123, Maharashtra, India. TEL:+91-11- 4507 6293 (DELHI) TEL:+91-22-2781 3385 (MUMBAI)	Plot No. E-10/3, MIDC sinnar (Malegaon) Industrial Area, Nashik, 422123, Maharashtra, India. TEL:+91-11- 4507 6293 (DELHI) TEL:+91-22-2781 3385 (MUMBAI)

MP 马达变频驱动一体机

MP Inverter-optimised AC Motor

BONENG