

BONENG



MX三相交流永磁
伺服马达 & AX伺
服驱动器

MX Three-Phase AC
Permanent Magnet
Servo Motor & AX
Servo Drives

(0.28kW~103kW)

Edit date 03/2026
Selection Catalogue: C05.0041

MX三相交流永磁伺服马达&AX伺服驱动器

MX Three-Phase AC Permanent Magnet Servo Motor & AX Servo Drives

BONENG

BONENG

Boneng Transmission

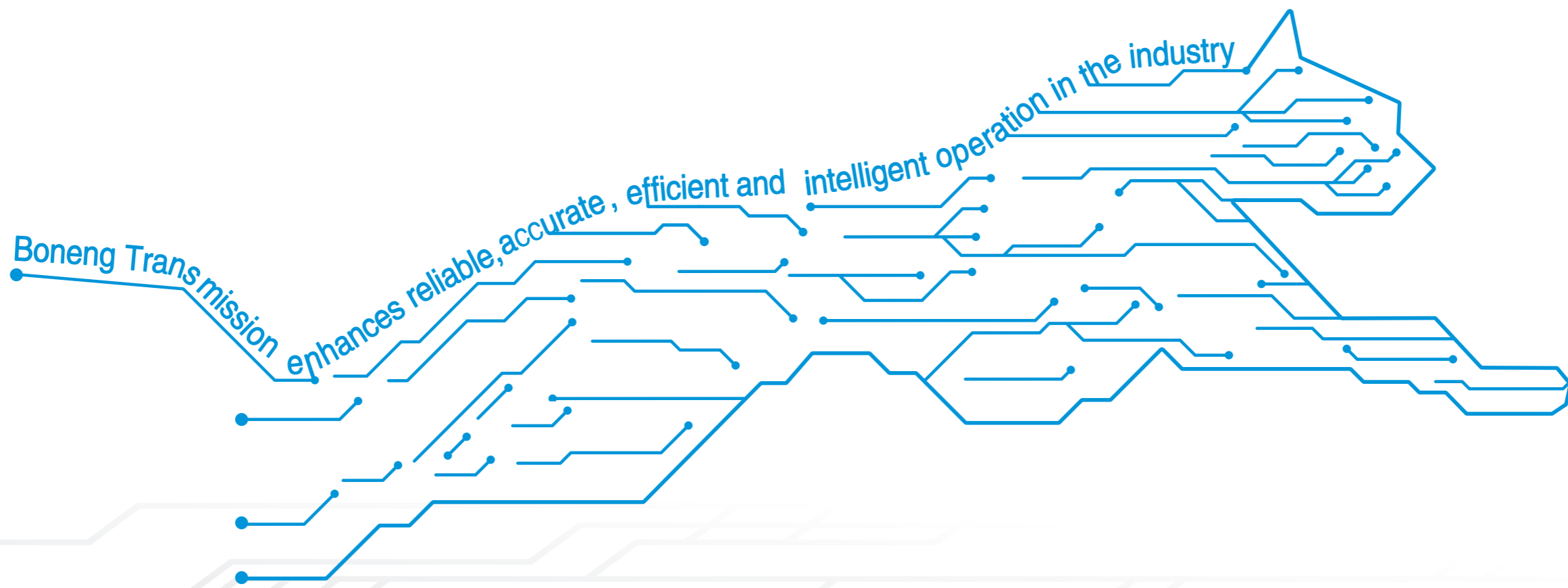

控制器/驱动器/马达/
齿轮马达/齿轮箱

Controller/ Drive/ Motor/
Gearmotor/ Gearbox

MX三相交流永磁伺服马达 & AX伺服驱动器

- ◆ 高防护等级(IP66)(28-100)
- ◆ 高动态响应, 高过载承载能力
- ◆ 高端永磁制动器、航空插头(28-100)
- ◆ 支持PROFINET及EtherCAT通讯
- ◆ PROFINET伺服支持IRT及RT应用
- ◆ 使用高精度22位绝对值编码器, 控制精度高
- ◆ 380VAC电压等级设计, 省去变压器等额外配置(28-100)
- ◆ 快速免螺丝控制端子, 方便接线及调试维护
- ◆ 丰富的IO接口, 及可定义输入或输出属性的控制端子

MX Three-Phase AC Permanent Magnet Servo Motor & AX Servo Drives

- ◆ High protection level (IP66)(28-100)
- ◆ High dynamic response, high overload carrying capacity
- ◆ High end permanent magnet brakes, aviation plugs(28-100)
- ◆ PROFINET and EtherCAT communication supported
- ◆ PROFINET servo supports RT and IRT applications
- ◆ High-precision 22-bit absolute value encoder used for high control precision
- ◆ 380VAC voltage level design, eliminating additional configurations such as transformers(28-100)
- ◆ Fast screw-free control terminals, convenient for wiring, debugging and maintenance
- ◆ Abundant IO interfaces and optional Bi-direction control terminals



产品广泛应用于机床、机器人、印刷机械、包装机械、纺织机械、自动化设备等各个领域。博能传动公司总部和各大区域的技术专家以及各区域办事处的应用工程师、售后服务技师竭诚为您提供全面的技术咨询和完美的服务。

Products are widely used in machine tool, robots, printing machines, packaging machines, textile machinery, automation equipment and other fields. Boneng Transmission company headquarters and major regional technical experts and regional offices of the application engineers, after-sales service technicians dedicated to provide you with comprehensive technical advice and perfect service.

目录

Contents

01.伺服马达概述	01	01.Motor overview	01
02.马达优点	01	02.Motor advantages	01
03.马达应用	01	03.Motor application	01
04.马达技术特征		04.Motor technical	
.....	02	characteristics	02
05.马达运行环境		05.Motor operating	
.....	03	environment	03
06.马达铭牌信息		06.Motor nameplate	
.....	03	information	03
07.马达制动器参数		07.Motor brake	
.....	04	parameters	04
08.马达和驱动器的选型及订		08.Selection and order	
货号		numbers of motor	
.....	05	and drives	05
09.马达型号表达方法		09.Motor model	
.....	09	indication method	09
10.马达特性及外形尺寸		10.Motor characteristics	
.....	10	and dimensions	10
11.马达电气连接		11.Motor electrical	
.....	21	connection	21
伺服驱动器		Servo Drive	
12.驱动器概述	23	12.Servo drive overview	23
13.驱动器整机安装尺寸图	24	13.Drive full machine	
.....	24	mounting size	24
14.驱动器控制模块	26	14.Control module	26
15.驱动器功率模块	36	15.Power module	36
16.驱动器操作面板	41	16.Operation panel	41
17.驱动器可选件	42	17.Options	42

伺服马达

1 伺服马达概述

MX系列伺服马达匹配博能AX系列伺服驱动器可组成精确定位的伺服系统。

MX伺服马达出厂常用的冷却方式为自然冷却，其他冷却方式，如强制风冷、水冷的伺服马达可特殊定制并实现更高的功率输出，具体参数另请咨询。

MX伺服马达标配防护等级为IP66(28-100)/IP54(132-180)，如需要IP67等级的伺服马达可定制。设计生产符合ISO、IEC、GB等相关标准要求。BONENG伺服马达适用于连续工作制(S1)，同时也满足大部分断续工作方式(S2-S10)。

2 马达优点

- ◆ 结构紧凑坚固
- ◆ 高防护等级
- ◆ 优良的径向跳动质量和细微的转矩波动
- ◆ 高动态响应
- ◆ 高过载承载能力
- ◆ 高效率
- ◆ 高精度、高分辨率编码器

3 马达应用

- ◆ 机床
- ◆ 机器人
- ◆ 印刷机械
- ◆ 包装机械
- ◆ 纺织机械
- ◆ 自动化设备

Servo Motor

1 Motor overview

MX series servo motor and AX series servo drive can compose a precise positioning servo system.

The commonly used cooling method of the MX series servo motor is natural cooling. Other cooling methods, such as forced air cooling and water cooling, can be specially customized to achieve higher power output. Please consult for specific parameters.

The standard protection level of the MX series servo motor is IP66(28-100)/IP54(132-180), Servo motor is with IP67 rating can be customized.

Design and production comply with ISO, IEC, GB and other relevant standards. BONENG servo motor is suitable for continuous duty (S1) and most of the intermittent duty (S2-S10).

2 Motor advantages

- ◆ Compact and robust
- ◆ High protection level
- ◆ Excellent radial runout quality and subtle torque ripple
- ◆ High dynamic response
- ◆ High overload carrying capacity
- ◆ High efficiency
- ◆ High-precision, high-resolution encoder

3 Motor application

- ◆ Machine tools
- ◆ Robots
- ◆ Printing machinery
- ◆ Packaging machinery
- ◆ Textile machinery
- ◆ Automation equipment

4 马达技术特征

4 Motor technical characteristics

马达型号	Motor model	三相交流同步伺服马达	Three-phase AC synchronous servo motor
磁性材料	Magnetic material	稀土永磁材料	Rare earth permanent magnet material
轴高(mm)	Shaft height (mm)	28、36、48、63、80、100、132、180	28、36、48、63、80、100、132、180
额定功率(kW)	Rated power (kW)	0.28-103	0.28-103
额定转矩(N.m)	Rated torque (N.m)	0.8-478	0.8-478
额定转速(r/min)	Rated speed (r/min)	1500、2000、3000、4500(28-100)	1500、2000、3000、4500(28-100)
绝缘等级	Insulation class	F	F
防护等级	Protection class	IP66(28-100) IP54(100-180)	IP66(28-100) IP54(100-180)
冷却方式	Cooling method	自然冷却 风冷	Natural cooling air-cooled
振动等级	Vibration level	A	A
噪声(dB)	Noise (dB)	55-70	55-70
径向圆跳精度、同轴度和端面圆跳精度等级	Runout Accuracy and Concentricity	N	N
安装形式	Installation form	IMB5	IMB5
驱动轴伸	Drive shaft extension	平键轴	Flat key shaft
编码器	Encoder	编码器分辨率 ²²	Encoder resolution ²²
连接器	Connector	动力和信号航空插头(28-100) 接线盒(132-180)	Power and signal aviation plugs(28-100) Junction box(132-180)
选件	Options	失电制动器	Power-off brake

5 马达运行环境

- ◆ 所允许的相对湿度:
-15°C ≤ T ≤ 20°C: 100%
20°C < T ≤ 30°C: 95%
30°C < T ≤ 40°C: 55%
- ◆ 对于更高的环境温度、以及(或者)高于海拔1000m的地点, 马达的额定功率换算系数为K_{ht}所允许的功率值: P_{n'} = P_n · K_{ht}

5 Motor operating environment

- ◆ Allowable relative humidity:
-15°C ≤ T ≤ 20°C: 100%
20°C < T ≤ 30°C: 95%
30°C < T ≤ 40°C: 55%
- ◆ For higher ambient temperatures, and above 1000m altitude, the motor's rated power conversion factor is the power value allowed by K_{ht}: P_{n'} = P_n · K_{ht}

对于不同高度和(或)不同环境温度的功率折算系数K_{ht}

Power conversion factor for different altitudes and different ambient temperatures K_{ht}

Altitude	对应海拔高度的环境温度 Ambient temperature corresponding to altitude					
	<30°C	30~40°C	45°C	50°C	55°C	60°C
1000 m	1.07	1	0.96	0.92	0.87	0.82
1500 m	1.04	0.97	0.93	0.89	0.84	0.79
2000 m	1	0.94	0.9	0.86	0.82	0.77
2500 m	0.96	0.9	0.86	0.83	0.78	0.74
3000 m	0.92	0.86	0.82	0.79	0.75	0.7
3500 m	0.88	0.82	0.79	0.75	0.71	0.67
4000 m	0.82	0.77	0.74	0.71	0.67	0.63

6 马达铭牌信息

6.1 马达铭牌信息(28-100)

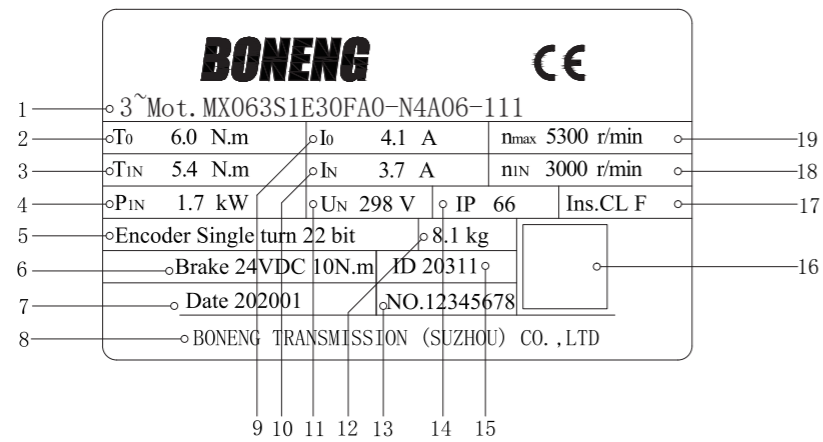

- | | | | |
|---------------|-----------------|-------------------------|----------------------|
| 1. 马达型号 | 11. 额定转速下的感应线电压 | 1. Model of motor | 11. Back EMF |
| 2. 静止转矩(100K) | 12. 重量 | 2. Static torque(100K) | 12. Weight |
| 3. 额定转矩(100K) | 13. 出厂编号 | 3. Rated torque(100K) | 13. Factory number |
| 4. 额定功率 | 14. 防护等级 | 4. Rated power | 14. Protection class |
| 5. 编码器参数 | 15. 马达ID | 5. Parameter of encoder | 15. ID of the motor |
| 6. 制动器参数 | 16. 二维码 | 6. Parameter of brake | 16. QR code |
| 7. 生产日期 | 17. 绝缘等级 | 7. Date in produced | 17. Insulation class |
| 8. 公司名称 | 18. 额定转速 | 8. Company name | 18. Rated speed |
| 9. 静止电流 | 19. 最大转速 | 9. Static current | 19. Maximum speed |
| 10. 额定电流 | | 10. Rated current | |

6.2 马达铭牌信息(132-180)

6.2 Motor nameplate information (132-180)

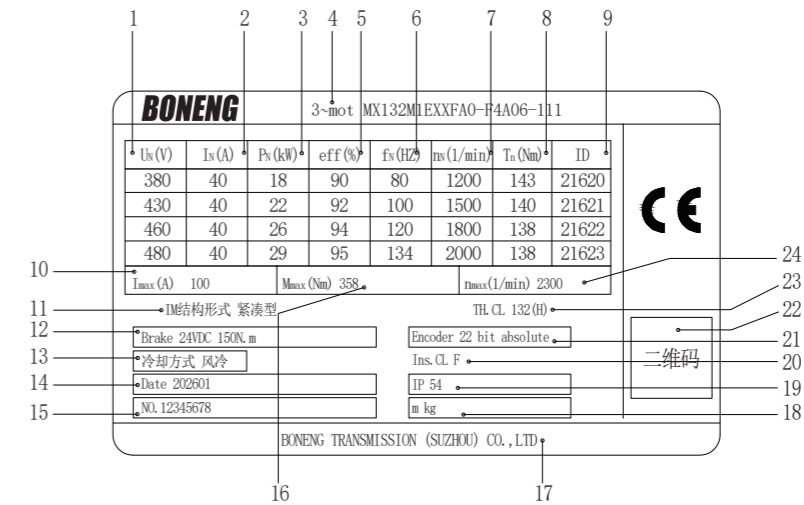

- | | | | |
|---------------|-----------|------------------------|--------------------------|
| 1. 额定电压 | 13. 冷却方式 | 1. Rated voltage | 13. Cooling method |
| 2. 额定电流 | 14. 生产日期 | 2. Rated current | 14. Date in produced |
| 3. 额定功率 | 15. 出厂编号 | 3. Rated power | 15. Factory number |
| 4. 马达型号 | 16. 最大转矩 | 4. Motor model | 16. Maximum torque |
| 5. 马达效率 | 17. 公司名称 | 5. Motor efficiency | 17. Company name |
| 6. 额定频率 | 18. 重量 | 6. Rated frequency | 18. Weight |
| 7. 额定转速 | 19. 防护等级 | 7. Rated speed | 19. Protection class |
| 8. 额定转矩(100K) | 20. 绝缘等级 | 8. Rated torque(100K) | 20. Insulation class |
| 9. 马达ID | 21. 编码器参数 | 9. Motor ID | 21. Parameter of encoder |
| 10. 最大电流 | 22. 二维码 | 10. Maximum current | 22. QR code |
| 11. 结构形式 | 23. 马达机座号 | 11. Structural form | 23. Motor frame size |
| 12. 制动器参数 | 24. 最大转速 | 12. Parameter of brake | 24. Maximum speed |

7 马达制动器参数

7 Motor brake parameters

制动器型号	Brake model	BN028	BN036	BN048	BN063	BN080	BN100	BN132	BN180
静摩擦力矩(N.m)	Static friction torque(N.m)	≥1.9	≥2.4	≥3.8	≥10	≥22	≥60	≥150	≥400
制动器功率(W)	Brake power(W)	8.76	6.74	13.4	18.5	25	40	85	110
转动惯量(kg·cm ²)	Moment of inertia(kg·cm ²)	0.09	0.11	0.39	0.78	2.55	14.7	26.5	175
额定间隙(mm)	Rated clearance(mm)	0.15	0.12	0.2	0.2	0.3	0.4	0.4	0.5
工作电压(VDC)	Operating voltage(VDC)	24±10%	24±10%	24±10%	24±10%	24±10%	24±10%	24±10%	24±10%
工作温度(°C)	Operating temperature(°C)	-15~120	-15~120	-15~120	-15~120	-15~120	-15~120	-15~120	-15~120
制动吸合时间(ms)	Brake pull-in time(ms)	≤20	≤20	≤30	≤25	≤30	≤50	≤260	≤390
制动释放时间(ms)	Brake release time(ms)	≤35	≤80	≤50	≤90	≤100	≤220	≤78	≤230
紧急制动次数(次)	Emergency braking times(times)	2000	2000	2000	500	2000	500	300	300
紧急制动次数(次/小时)	Emergency braking times(times/hour)	20	20	20	20	20	20	17	12
最大紧急制动转速(r/min)	Maximum emergency braking speed(r/min)	6000	6000	6000	3000	3000	3000	4800	3300
适配马达机座号	Compatible motor frame size	028	036	048	063/080S	080M/100S	100M/100L	132	180

8 马达和驱动器的
选型及订货号

8 Selection and order
numbers of motor
and drives

马达 机座 号	马达额定 功率 (kW)	马达额定 转速 (r/min)	马达 能效 等级	马达容 许最大 惯量比	马达ID		马达订货号	驱动器功率 模块订货号
					无制动器	带制动器		
					Motor ID			
Motor frame size	Motor rated power (kw)	Motor rated speed (r/min)	Motor energy efficiency class	Motor allowable maximum inertia ratio	Without brake	With brake	Motor order number	Drive power module order number
028S	0.28	3000	IE5	35	11010	21010	MXO28S1E30FA0-N4□06-111	AX-PM26-B3A75-□
028M	0.42	3000	IE5	25	11012	21012	MXO28M1E30FA0-N4□06-111	AX-PM26-B3A75-□
028S	0.38	4500	IE5	30	11011	21011	MXO28S1E45FA0-N4□06-111	AX-PM26-B3A75-□
028M	0.54	4500	IE5	25	11013	21013	MXO28M1E45FA0-N4□06-111	AX-PM26-B3B15-□
036S	0.47	3000	IE5	15	11110	21110	MXO36S1E30FA0-N4□06-111	AX-PM26-B3A75-□
036M	0.75	3000	IE5	15	11112	21112	MXO36M1E30FA0-N4□06-111	AX-PM26-B3B15-□
036S	0.66	4500	IE5	10	11111	21111	MXO36S1E45FA0-N4□06-111	AX-PM26-B3B15-□
036M	0.8	4500	IE5	10	11113	21113	MXO36M1E45FA0-N4□06-111	AX-PM26-B3B15-□
048S	1	3000	IE5	10	11210	21210	MXO48S1E30FA0-N4□06-111	AX-PM26-B3B15-□
048M	1.5	3000	IE5	10	11212	21212	MXO48M1E30FA0-N4□06-111	AX-PM26-B3B22-□
048S	1.32	4500	IE5	5	11211	21211	MXO48S1E45FA0-N4□06-111	AX-PM26-B3B22-□
048M	1.55	4500	IE5	5	11213	21213	MXO48M1E45FA0-N4□06-111	AX-PM26-B3B22-□
063S	1.2	2000	IE5	10	11310	21310	MXO63S1E20FA0-N4□06-111	AX-PM26-B3B22-□
063M	2.05	2000	IE5	5	11313	21313	MXO63M1E20FA0-N4□06-111	AX-PM26-B3B40-□
063S	1.7	3000	IE5	5	11311	21311	MXO63S1E30FA0-N4□06-111	AX-PM26-B3B30-□
063M	2.76	3000	IE5	10	11314	21314	MXO63M1E30FA0-N4□06-111	AX-PM26-B3B55-□
063S	2.07	4500	IE5	5	11312	21312	MXO63S1E45FA0-N4□06-111	AX-PM26-B3B30-□
063M	2.97	4500	IE5	5	11315	21315	MXO63M1E45FA0-N4□06-111	AX-PM26-B3B55-□
080S	2.39	2000	IE5	5	11410	21410	MXO80S1E20FA0-N4□06-111	AX-PM26-B3B40-□
080M	3.98	2000	IE5	5	11412	21412	MXO80M1E20FA0-N4□06-111	AX-PM26-B3B75-□
080S	3.24	3000	IE5	5	11411	21411	MXO80S1E30FA0-N4□06-111	AX-PM26-B3B55-□
080M	5.03	3000	IE5	5	11413	21413	MXO80M1E30FA0-N4□06-111	AX-PM26-B3B75-□
100S	4.08	1500	IE5	5	11510	21510	MX100S1E15FA0-N4□06-111	AX-PM26-B3B75-□
100M	6.6	1500	IE5	5	11513	21513	MX100M1E15FA0-N4□06-111	AX-PM26-B3C11-□
100L	9.11	1500	IE5	5	11516	21516	MX100L1E15FA0-N4□06-111	AX-PM26-B3C15-□
100S	5.03	2000	IE5	5	11511	21511	MX100S1E20FA0-N4□06-111	AX-PM26-B3B75-□
100M	7.96	2000	IE5	5	11514	21514	MX100M1E20FA0-N4□06-111	AX-PM26-B3C15-□
100L	10.06	2000	IE5	5	11517	21517	MX100L1E20FA0-N4□06-111	AX-PM26-B3C15-□
100S	6.28	3000	IE5	5	11512	21512	MX100S1E30FA0-N4□06-111	AX-PM26-B3C11-□
100M	8.8	3000	IE5	5	11515	21515	MX100M1E30FA0-N4□06-111	AX-PM26-B3C15-□
100L	14	2000	IE5	5	11518	21518	MX100L1E20FA0-F4□06-111	AX-PM26-B3C18-□

Without brake N Without filter N
With brake A With filter F

驱动器 操作面板 订货号	驱动器控制模块订货号	信号线订货号	动力线订货号	驱动器可选件 制动电阻 订货号
Drive operator panel order number	Driver control module order number	Signal cable order number	Power cable order number	Drive options: Braking resistor order number
A1-OP25	AX-CM□□-□□-PE	A1-H17-A□□□-□□□	A1-H□□□-A15-□□□	A1-H02-A06-K-D75
A1-OP25	AX-CM□□-□□-PE	A1-H17-A□□□-□□□	A1-H□□□-A15-□□□	A1-H02-A06-K-D75
A1-OP25	AX-CM□□-□□-PE	A1-H17-A□□□-□□□	A1-H□□□-A15-□□□	A1-H02-A06-K-D75
A1-OP25	AX-CM□□-□□-PE	A1-H17-A□□□-□□□	A1-H□□□-A15-□□□	A1-H02-A08-K-D39
A1-OP25	AX-CM□□-□□-PE	A1-H17-A□□□-□□□	A1-H□□□-A15-□□□	A1-H02-A06-K-D75
A1-OP25	AX-CM□□-□□-PE	A1-H17-A□□□-□□□	A1-H□□□-A15-□□□	A1-H02-A08-K-D39
A1-OP25	AX-CM□□-□□-PE	A1-H17-A□□□-□□□	A1-H□□□-A15-□□□	A1-H02-A08-K-D39
A1-OP25	AX-CM□□-□□-PE	A1-H17-A□□□-□□□	A1-H□□□-A15-□□□	A1-H02-A08-K-D39
A1-OP25	AX-CM□□-□□-PE	A1-H17-A□□□-□□□	A1-H□□□-A15-□□□	A1-H02-A08-K-D39
A1-OP25	AX-CM□□-□□-PE	A1-H17-A□□□-□□□	A1-H□□□-A15-□□□	A1-H02-A15-K-D18
A1-OP25	AX-CM□□-□□-PE	A1-H17-A□□□-□□□	A1-H□□□-A15-□□□	A1-H02-A15-K-D18
A1-OP25	AX-CM□□-□□-PE	A1-H17-A□□□-□□□	A1-H□□□-A15-□□□	A1-H02-A15-K-D18
A1-OP25	AX-CM□□-□□-PE	A1-H17-A□□□-□□□	A1-H□□□-A15-□□□	A1-H02-A15-K-D18
A1-OP25	AX-CM□□-□□-PE	A1-H17-A□□□-□□□	A1-H□□□-A15-□□□	A1-H02-A30-K-D10
A1-OP25	AX-CM□□-□□-PE	A1-H17-A□□□-□□□	A1-H□□□-A15-□□□	A1-H02-A15-K-D18
A1-OP25	AX-CM□□-□□-PE	A1-H17-A□□□-□□□	A1-H□□□-A15-□□□	A1-H02-A30-K-D10
A1-OP25	AX-CM□□-□□-PE	A1-H17-A□□□-□□□	A1-H□□□-A15-□□□	A1-H02-A15-K-D18
A1-OP25	AX-CM□□-□□-PE	A1-H17-A□□□-□□□	A1-H□□□-A15-□□□	A1-H02-A30-K-D10
A1-OP25	AX-CM□□-□□-PE	A1-H17-A□□□-□□□	A1-H□□□-A25-□□□	A1-H02-A30-K-D10
A1-OP25	AX-CM□□-□□-PE	A1-H17-A□□□-□□□	A1-H□□□-A25-□□□	A1-H02-A40-K-C75
A1-OP25	AX-CM□□-□□-PE	A1-H17-A□□□-□□□	A1-H□□□-A25-□□□	A1-H02-A30-K-D10
A1-OP25	AX-CM□□-□□-PE	A1-H17-A□□□-□□□	A1-H□□□-A40-□□□	A1-H02-A40-K-C75
A1-OP25	AX-CM□□-□□-PE	A1-H17-A□□□-□□□	A1-H□□□-A40-□□□	A1-H02-A80-K-C36
A1-OP25	AX-CM□□-□□-PE	A1-H17-A□□□-□□□	A1-H□□□-A40-□□□	A1-H02-A80-K-C36
A1-OP25	AX-CM□□-□□-PE	A1-H17-A□□□-□□□	A1-H□□□-A40-□□□	A1-H02-A40-K-C75
A1-OP25	AX-CM□□-□□-PE	A1-H17-A□□□-□□□	A1-H□□□-A40-□□□	A1-H02-A80-K-C36
A1-OP25	AX-CM□□-□□-PE	A1-H17-A□□□-□□□	A1-H□□□-A40-□□□	A1-H02-A80-K-C36
A1-OP25	AX-CM□□-□□-PE	A1-H17-A□□□-□□□	A1-H□□□-A40-□□□	A1-H02-A80-K-C36
A1-OP25	AX-CM□□-□□-PE	A1-H17-A□□□-□□□	A1-H□□□-A60-□□□	A1-H02-B10-K-C27

55 EA Without battery 12 B30(3m) Without brake 18 B30(3m)
PA With battery 13 B50(5m) With brake 16 B50(5m)
53 PA Without battery 14 B70(7m) B70(7m)
With battery 15 C10(10m) C10(10m)
C15(15m) C15(15m)
C20(20m) C20(20m)
C30(30m) C30(30m)
C40(40m) C40(40m)
C50(50m) C50(50m)

马达机座号	马达额定功率 (kW)	马达额定转速 (r/min)	马达能效等级	马达容许最大惯量比	马达ID		马达订货号	驱动器功率模块订货号
					无制动器	带制动器		
					Motor ID			
Motor frame size	Motor rated power (kw)	Motor rated speed (r/min)	Motor energy efficiency class	Motor allowable maximum inertia ratio	Without brake	With brake	Motor order number	Drive power module order number
132M	18	1200	IE5	3	11620	21620	MX132M1E12FA0-F4□06-111	AX-PM26-B3C22-□
132M	22	1500	IE5	3	11621	21621	MX132M1E15FA0-F4□06-111	AX-PM26-B3C22-□
132M	26	1800	IE5	3	11622	21622	MX132M1E18FA0-F4□06-111	AX-PM26-B3C22-□
132M	29	2000	IE5	3	11623	21623	MX132M1E20FA0-F4□06-111	AX-PM26-B3C22-□
132M	33	2200	IE5	3	11624	21624	MX132M1E22FA0-F4□06-111	AX-PM26-B3C37-□
132M	37	2500	IE5	3	11625	21625	MX132M1E25FA0-F4□06-111	AX-PM26-B3C37-□
132M	42	2800	IE5	3	11626	21626	MX132M1E28FA0-F4□06-111	AX-PM26-B3C37-□
132M	45	3000	IE5	3	11627	21627	MX132M1E30FA0-F4□06-111	AX-PM26-B3C37-□
180M	38	800	IE5	3	11720	21720	MX180M1E08FA0-F4□06-111	AX-PM26-B3C45-□
180M	47	1000	IE5	3	11721	21721	MX180M1E10FA0-F4□06-111	AX-PM26-B3C45-□
180M	57	1200	IE5	3	11722	21722	MX180M1E12FA0-F4□06-111	AX-PM26-B3C45-□
180M	66	1400	IE5	3	11723	21723	MX180M1E14FA0-F4□06-111	AX-PM26-B3C45-□
180M	74	1500	IE5	3	11724	21724	MX180M1E15FA0-F4□06-111	AX-PM26-B3C90-□
180M	85	1700	IE5	3	11725	21725	MX180M1E17FA0-F4□06-111	AX-PM26-B3C90-□
180M	94	1900	IE5	3	11726	21726	MX180M1E19FA0-F4□06-111	AX-PM26-B3C90-□
180M	103	2100	IE5	3	11727	21727	MX180M1E21FA0-F4□06-111	AX-PM26-B3C90-□

Without brake N Without filter N
With brake A With filter F

注:MX132及以上机座号, 马达制动器线和动力线由客户自购
所有风冷马达的风机线由客户自购

Note: For MX132 and above frame numbers, the motor brake wires and power wires are purchased by the customer.
All cooling fan motor wires are purchased by the customer.

驱动器操作面板订货号	驱动器控制模块订货号	信号线订货号	驱动器供电电压/VAC	驱动器可选件制动电阻订货号
Drive operator panel order number	Driver control module order number	Signal cable order number	Driver power supply voltage / VAC	Drive options: Braking resistor order number
A1-OP25	AX-CM□□-□□-PE	A1-H19-A□□-□□□	380	A1-H02-B10-K-C27
A1-OP25	AX-CM□□-□□-PE	A1-H19-A□□-□□□	430	A1-H02-B10-K-C27
A1-OP25	AX-CM□□-□□-PE	A1-H19-A□□-□□□	460	A1-H02-B10-K-C27
A1-OP25	AX-CM□□-□□-PE	A1-H19-A□□-□□□	480	A1-H02-B10-K-C27
A1-OP25	AX-CM□□-□□-PE	A1-H19-A□□-□□□	380	A1-H02-B20-K-C15
A1-OP25	AX-CM□□-□□-PE	A1-H19-A□□-□□□	430	A1-H02-B20-K-C15
A1-OP25	AX-CM□□-□□-PE	A1-H19-A□□-□□□	460	A1-H02-B20-K-C15
A1-OP25	AX-CM□□-□□-PE	A1-H19-A□□-□□□	480	A1-H02-B20-K-C15
A1-OP25	AX-CM□□-□□-PE	A1-H19-A□□-□□□	380	A1-H02-B30-K-C10
A1-OP25	AX-CM□□-□□-PE	A1-H19-A□□-□□□	430	A1-H02-B30-K-C10
A1-OP25	AX-CM□□-□□-PE	A1-H19-A□□-□□□	460	A1-H02-B30-K-C10
A1-OP25	AX-CM□□-□□-PE	A1-H19-A□□-□□□	480	A1-H02-B30-K-C10
A1-OP25	AX-CM□□-□□-PE	A1-H19-A□□-□□□	380	A1-H02-B40-K-B75
A1-OP25	AX-CM□□-□□-PE	A1-H19-A□□-□□□	430	A1-H02-B40-K-B75
A1-OP25	AX-CM□□-□□-PE	A1-H19-A□□-□□□	460	A1-H02-B40-K-B75
A1-OP25	AX-CM□□-□□-PE	A1-H19-A□□-□□□	480	A1-H02-B40-K-B75

55 EA Without battery 12 B30(3m)
PA With battery 13 B50(5m)
53 PA Without battery 14 B70(7m)
With battery 15 C10(10m)
C15(15m)
C20(20m)
C30(30m)
C40(40m)
C50(50m)

9 马达型号表示方法

9 Motor model indication method

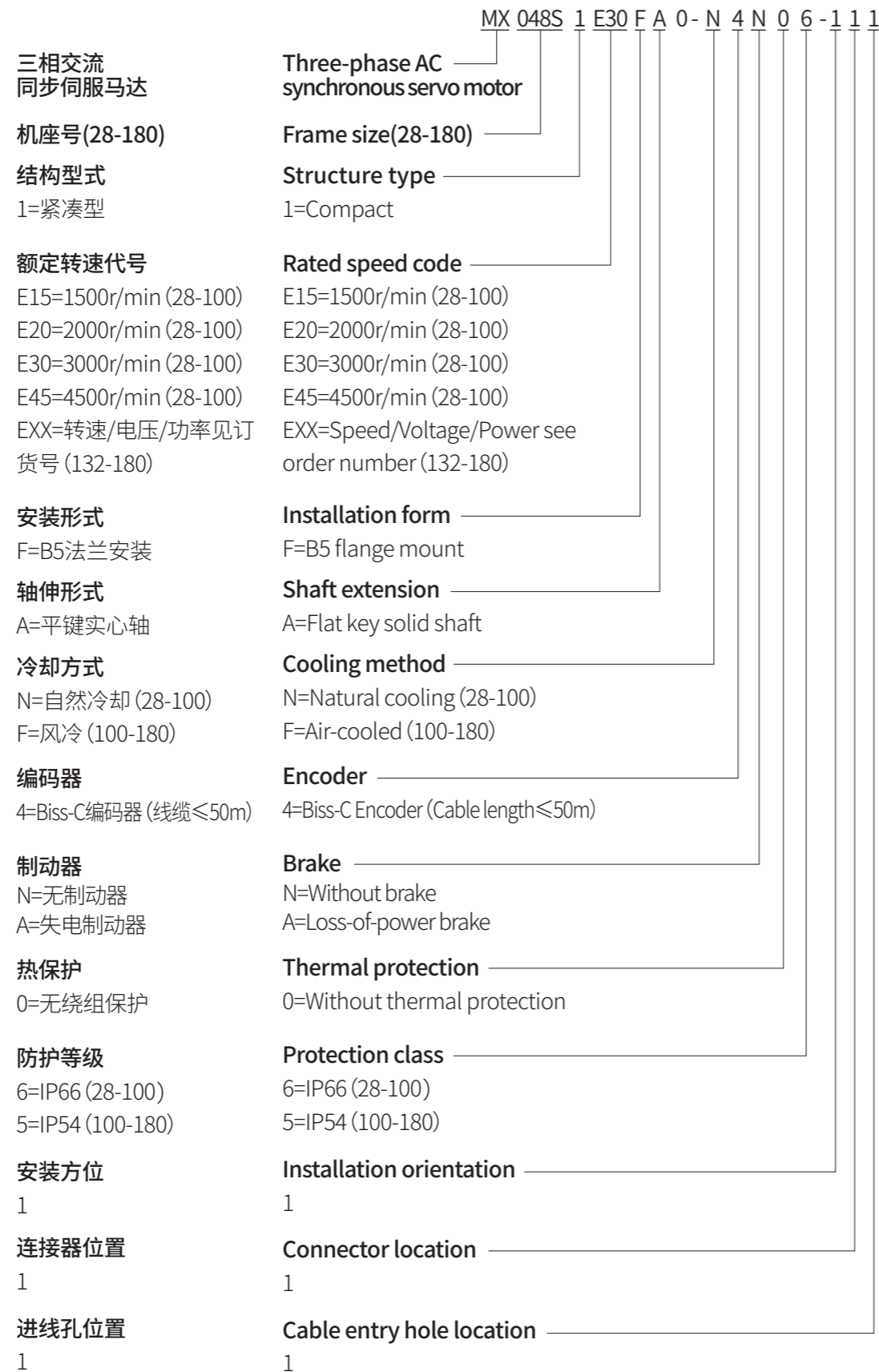

整机标配颜色 RAL9006 The standard RAL9006 color of the whole machine

10 马达特性及外形尺寸

10 Motor characteristics and dimensions

10.1 机座号028伺服马达参数、外形尺寸以及特性曲线

马达型号	Motor model	MX028S1E30FA0 -N4□06-111	MX028M1E30FA0 -N4□06-111	MX028S1E45FA0 -N4□06-111	MX028M1E45FA0 -N4□06-111
额定转速 $n_{IN}(r/min)$	Rated speed $n_{IN}(r/min)$	3000	3000	4500	4500
额定功率 $P_{IN}(kW)$	Rated power $P_{IN}(kW)$	0.28	0.42	0.38	0.54
额定电流 $I_{N(100K)}(A)$	Rated current $I_{N(100K)}(A)$	0.9	1	1.2	1.8
额定转矩 $T_{IN(100K)}(N.m)$	Rated torque $T_{IN(100K)}(N.m)$	0.9	1.3	0.8	1.1
静止电流 $I_0(A)$	Static current $I_0(A)$	1	1.2	1.3	2
静止转矩 $T_0(N.m)$	Static torque $T_0(N.m)$	1	1.5	0.9	1.2
最大转速 $n_{max\ drive}(r/min)$	Maximum speed $n_{max\ drive}(r/min)$	5400	4200	6000	6000
最大电流 $I_{max\ drive}(A)$	Maximum current $I_{max\ drive}(A)$	2.7	3	3.6	5.4
最大转矩 $T_{max\ drive}(N.m)$	Maximum torque $T_{max\ drive}(N.m)$	2.7	3.9	2.4	3.3
极限电流 $I_{max}(A)$	Limit current $I_{max}(A)$	4	4.8	5.8	10
极限转矩 $T_{max}(N.m)$	Limit torque $T_{max}(N.m)$	4	6	4	6
转动惯量 $J(10^{-4}kg.m^2)$	Moment of inertia $J(10^{-4}kg.m^2)$	0.15(0.17)	0.25(0.27)	0.15(0.17)	0.25(0.27)
重量 $m(kg)$	Weight $m(kg)$	1.8(2)	2.4(2.7)	1.8(2)	2.4(2.7)
止口到动力连接器长度 $KB1(mm)$	Socket to Power Connector Length $KB1(mm)$	83.8	128.8	83.8	128.8
动力连接器到信号连接器长度 $KB2(mm)$	Power Connector to Signal Connector Length $KB2(mm)$	51(75)	51(75)	51(75)	51(75)
整机长度 $LL(mm)$	Overall length $LL(mm)$	148(172)	193(217)	148(172)	193(217)

注：括号内为带制动器的数据 Note: The data in parentheses are with brake

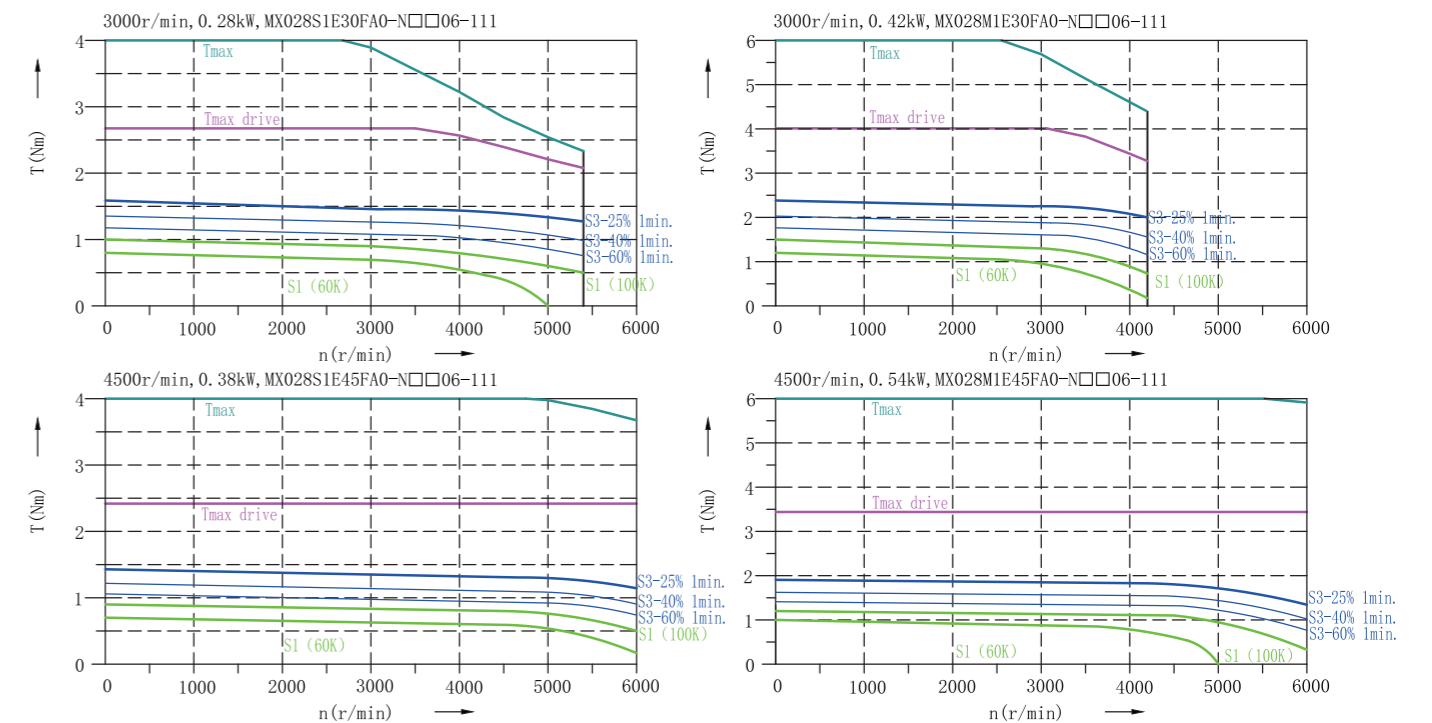
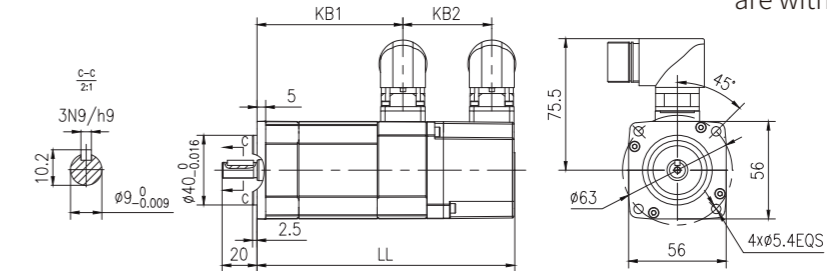

10.2 机座号036伺服马达参数、外形尺寸以及特性曲线

10.2 Frame size 036 servo motor parameters, dimensions and characteristic curve

马达型号	Motor model	MX036S1E30FA0 -N4□06-111	MX036M1E30FA0 -N4□06-111	MX036S1E45FA0 -N4□06-111	MX036M1E45FA0 -N4□06-111
额定转速 n_{IN} (r/min)	Rated speed n_{IN} (r/min)	3000	3000	4500	4500
额定功率 P_{IN} (kW)	Rated power P_{IN} (kW)	0.47	0.75	0.66	0.8
额定电流 $I_{N(100K)}$ (A)	Rated current $I_{N(100K)}$ (A)	1.15	1.6	1.9	1.7
额定转矩 $T_{IN(100K)}$ (N.m)	Rated torque $T_{IN(100K)}$ (N.m)	1.5	2.4	1.4	1.7
静止电流 I_0 (A)	Static current I_0 (A)	1.3	1.8	2.1	1.9
静止转矩 T_0 (N.m)	Static torque T_0 (N.m)	1.6	2.6	1.6	1.9
最大转速 $n_{max\ drive}$ (r/min)	Maximum speed $n_{max\ drive}$ (r/min)	6000	5200	6000	6000
最大电流 $I_{max\ drive}$ (A)	Maximum current $I_{max\ drive}$ (A)	3.45	4.8	5.7	5.1
最大转矩 $T_{max\ drive}$ (N.m)	Maximum torque $T_{max\ drive}$ (N.m)	4.5	7.2	4.2	5.1
极限电流 I_{max} (A)	Limit current I_{max} (A)	4.5	6.2	7.2	9
极限转矩 T_{max} (N.m)	Limit torque T_{max} (N.m)	5.5	9	5.5	9
转动惯量 $J(10^{-4} \text{ kg} \cdot \text{m}^2)$	Moment of inertia $J(10^{-4} \text{ kg} \cdot \text{m}^2)$	0.74 (0.77)	1.41 (1.44)	0.74 (0.77)	1.41 (1.44)
重量 m (kg)	Weight m (kg)	2.7 (3.1)	3.9 (4.3)	2.7 (3.1)	3.9 (4.3)
止口到动力连接器长度 KB1 (mm)	Socket to Power Connector Length KB1 (mm)	86.7	131.7	86.7	131.7
动力连接器到信号连接器长度 KB2 (mm)	Power Connector to Signal Connector Length KB2 (mm)	55.5 (83.8)	55.5 (83.8)	55.5 (83.8)	55.5 (83.8)
整机长度 LL (mm)	Overall length LL (mm)	155.5 (183.8)	200.5 (228.8)	155.5 (183.8)	200.5 (228.8)

注：括号内为带制动器的数据

Note: The data in parentheses are with brake

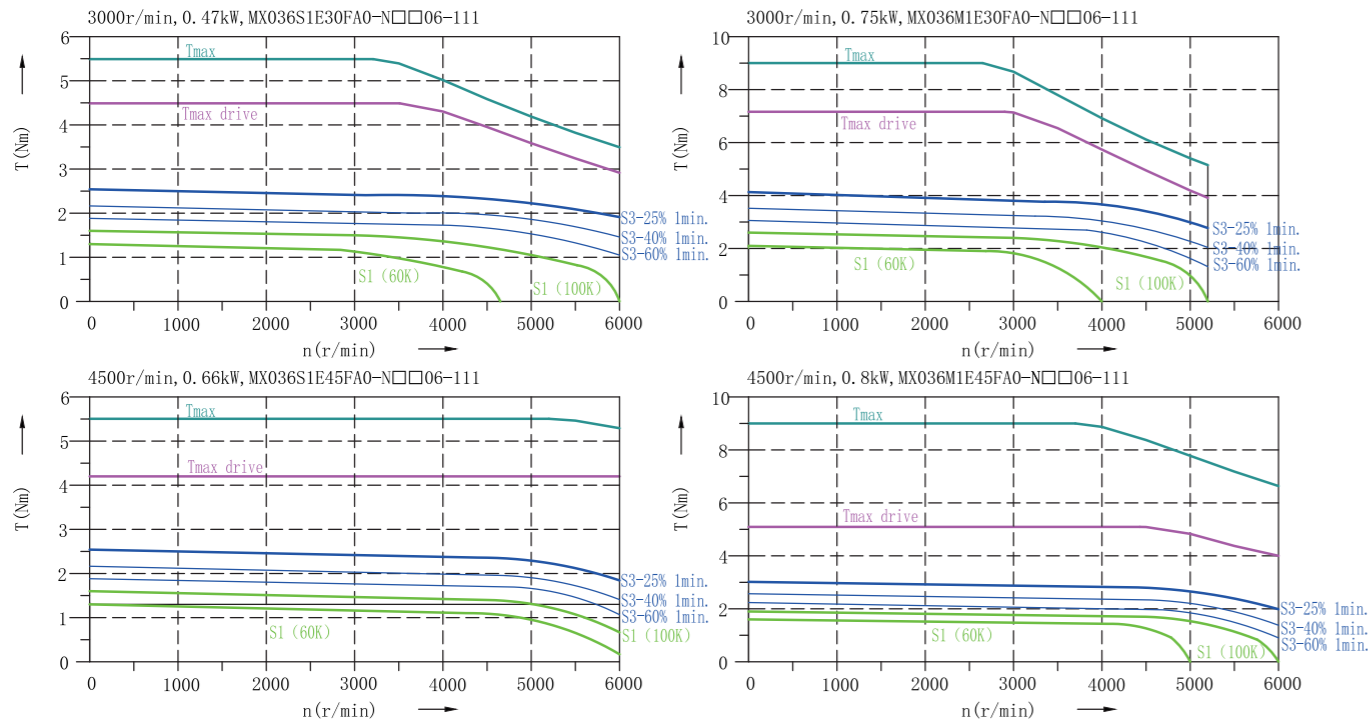
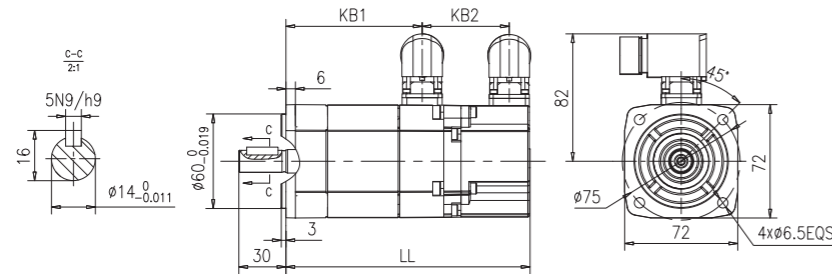

10.3 机座号048伺服马达参数、外形尺寸以及特性曲线

10.3 Frame size 048 servo motor parameters, dimensions and characteristic curve

马达型号	Motor model	MX048S1E30FA0 -N4□06-111	MX048M1E30FA0 -N4□06-111	MX048S1E45FA0 -N4□06-111	MX048M1E45FA0 -N4□06-111
额定转速 n_{IN} (r/min)	Rated speed n_{IN} (r/min)	3000	3000	4500	4500
额定功率 P_{IN} (kW)	Rated power P_{IN} (kW)	1	1.5	1.32	1.55
额定电流 $I_{N(100K)}$ (A)	Rated current $I_{N(100K)}$ (A)	2.2	3	2.8	3.3
额定转矩 $T_{IN(100K)}$ (N.m)	Rated torque $T_{IN(100K)}$ (N.m)	3.2	4.8	2.8	3.3
静止电流 I_0 (A)	Static current I_0 (A)	2.5	3.4	3.1	3.4
静止转矩 T_0 (N.m)	Static torque T_0 (N.m)	3.5	5.3	3.1	3.7
最大转速 $n_{max\ drive}$ (r/min)	Maximum speed $n_{max\ drive}$ (r/min)	5400	4900	6000	6000
最大电流 $I_{max\ drive}$ (A)	Maximum current $I_{max\ drive}$ (A)	6.6	9	8.4	9.9
最大转矩 $T_{max\ drive}$ (N.m)	Maximum torque $T_{max\ drive}$ (N.m)	9.6	14.4	8.4	9.9
极限电流 I_{max} (A)	Limit current I_{max} (A)	9.3	14.8	13	23
极限转矩 T_{max} (N.m)	Limit torque T_{max} (N.m)	13	23	13	23
转动惯量 $J(10^{-4} \text{ kg} \cdot \text{m}^2)$	Moment of inertia $J(10^{-4} \text{ kg} \cdot \text{m}^2)$	2.53 (2.76)	4.85 (5.08)	2.53 (2.76)	4.85 (5.08)
重量 m (kg)	Weight m (kg)	4.5 (5.2)	7 (7.7)	4.5 (5.2)	7 (7.7)
止口到动力连接器长度 KB1 (mm)	Socket to Power Connector Length KB1 (mm)	92.7	142.7	92.7	142.7
动力连接器到信号连接器长度 KB2 (mm)	Power Connector to Signal Connector Length KB2 (mm)	56 (95.5)	56 (95.5)	56 (95.5)	56 (95.5)
整机长度 LL (mm)	Overall length LL (mm)	162.5 (202)	212.5 (252)	162.5 (202)	212.5 (252)

注：括号内为带制动器的数据

Note: The data in parentheses are with brake

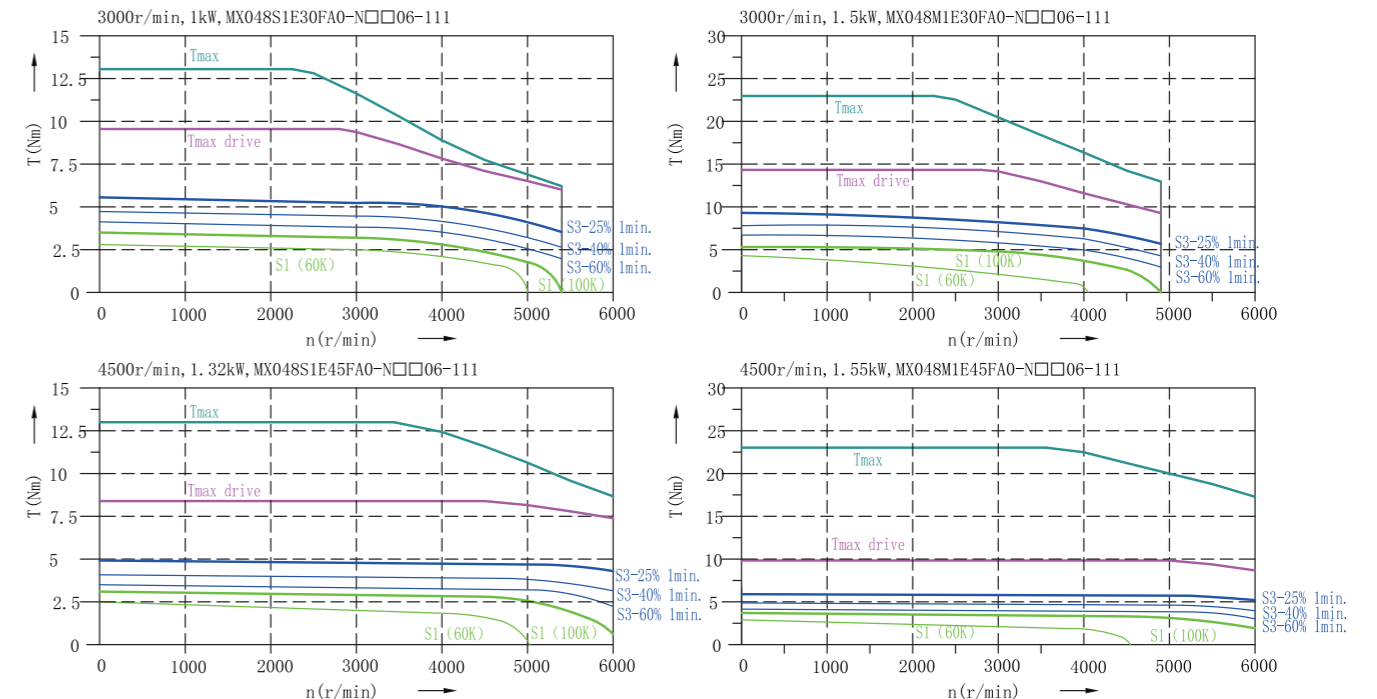
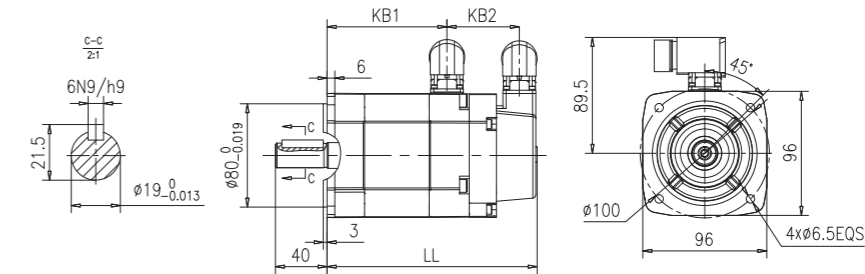

10.4 机座号063伺服马达参数、外形尺寸以及特性曲线

10.4 Frame size 063 servo motor parameters, dimensions and characteristic curve

马达型号	Motor model	MX063S1E20FA0 -N4□06-111	MX063M1E20FA0 -N4□06-111	MX063S1E30FA0 -N4□06-111	MX063M1E30FA0 -N4□06-111	MX063S1E45FA0 -N4□06-111	MX063M1E45FA0 -N4□06-111
额定转速	n_{IN} (r/min)	2000	2000	3000	3000	4500	4500
额定功率	P_{IN} (kW)	1.2	2.05	1.7	2.76	2.07	2.97
额定电流	$I_{N(100K)}$ (A)	2.8	4.6	3.6	6	4.3	6.4
额定转矩	$T_{IN(100K)}$ (N.m)	5.7	9.8	5.4	8.8	4.4	6.3
静止电流	I_0 (A)	3.1	5.1	4	6.7	4.8	7.1
静止转矩	T_0 (N.m)	6.3	10.9	6	9.8	4.9	7
最大转速	$n_{max drive}$ (r/min)	3800	3850	5300	5350	6000	6000
最大电流	$I_{max drive}$ (A)	8.4	13.8	10.8	18	12.9	19.2
最大转矩	$T_{max drive}$ (N.m)	17.1	29.4	16.2	26.4	13.2	18.9
极限电流	I_{max} (A)	11.8	20.1	16	29.4	23.5	43.6
极限转矩	T_{max} (N.m)	24	43	24	43	24	43
转动惯量	$J(10^{-4}kg.m^2)$	7.36(7.57)	14.09(14.31)	7.36(7.57)	14.09(14.31)	7.36(7.57)	14.09(14.31)
重量	m(kg)	7.1(8)	10.9(11.8)	7.1(8)	10.9(11.8)	7.1(8)	10.9(11.8)
止口到动力连接器长度	KB1(mm)	93.3	141.3	93.3	141.3	93.3	141.3
动力连接器到信号连接器长度	KB2(mm)	56.5(85)	56.5(85)	56.5(85)	56.5(85)	56.5(85)	56.5(85)
整机长度	LL(mm)	163.5(192)	211.5(240)	163.5(192)	211.5(240)	163.5(192)	211.5(240)

注：括号内为带制动器的数据

Note: The data in parentheses are with brake

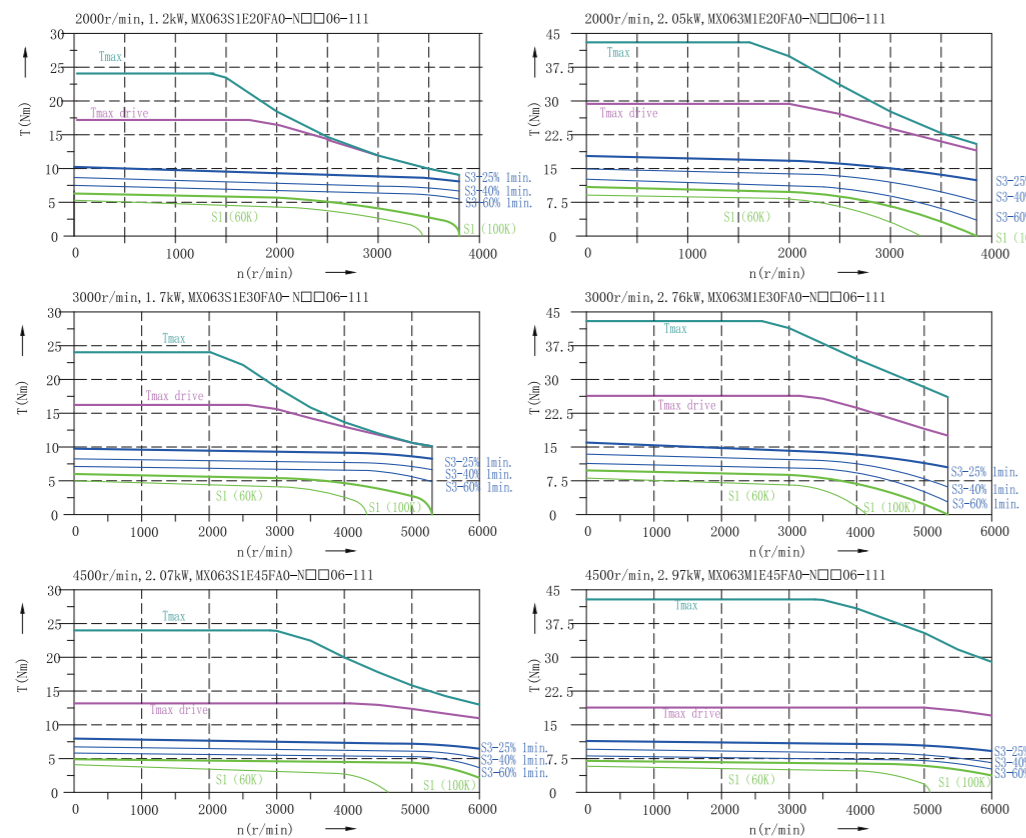
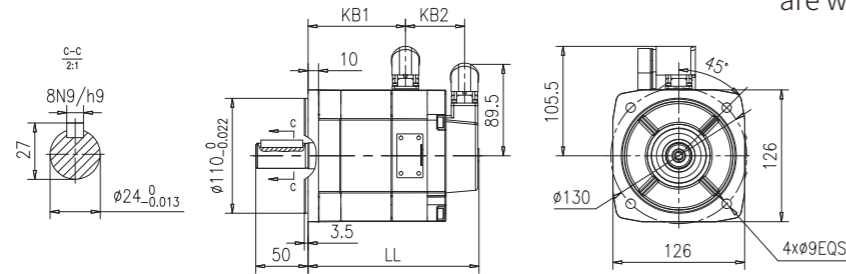

10.5 机座号080伺服马达参数、外形尺寸以及特性曲线

10.5 Frame size 080 servo motor parameters, dimensions and characteristic curve

马达型号	Motor model	MX080S1E20FA0 -N4□06-111	MX080M1E20FA0 -N4□06-111	MX080S1E30FA0 -N4□06-111	MX080M1E30FA0 -N4□06-111
额定转速	n_{IN} (r/min)	2000	2000	3000	3000
额定功率	P_{IN} (kW)	2.39	3.98	3.24	5.03
额定电流	$I_{N(100K)}$ (A)	5	8.1	7.1	9.6
额定转矩	$T_{IN(100K)}$ (N.m)	11.4	19	10.3	16
静止电流	I_0 (A)	5.7	9.2	8.1	10.9
静止转矩	T_0 (N.m)	13	21.6	11.7	18.2
最大转速	$n_{max drive}$ (r/min)	3500	3350	5400	4700
最大电流	$I_{max drive}$ (A)	15	24.3	21.3	28.8
最大转矩	$T_{max drive}$ (N.m)	34.2	57	30.9	48
极限电流	I_{max} (A)	22.4	40.5	35.3	56.9
极限转矩	T_{max} (N.m)	51	95	51	95
转动惯量	$J(10^{-4}kg.m^2)$	25.49(25.59)	48.89(50.08)	25.49(25.59)	48.89(50.08)
重量	m(kg)	13.6(14.3)	21.9(23.9)	13.6(14.3)	21.9(23.9)
止口到动力连接器长度	KB1(mm)	116.8	184.7	116.8	184.7
动力连接器到信号连接器长度	KB2(mm)	62.5(83)	62.5(110.5)	62.5(83)	62.5(110.5)
整机长度	LL(mm)	193(213.5)	261(309)	193(213.5)	261(309)

注：括号内为带制动器的数据

Note: The data in parentheses are with brake

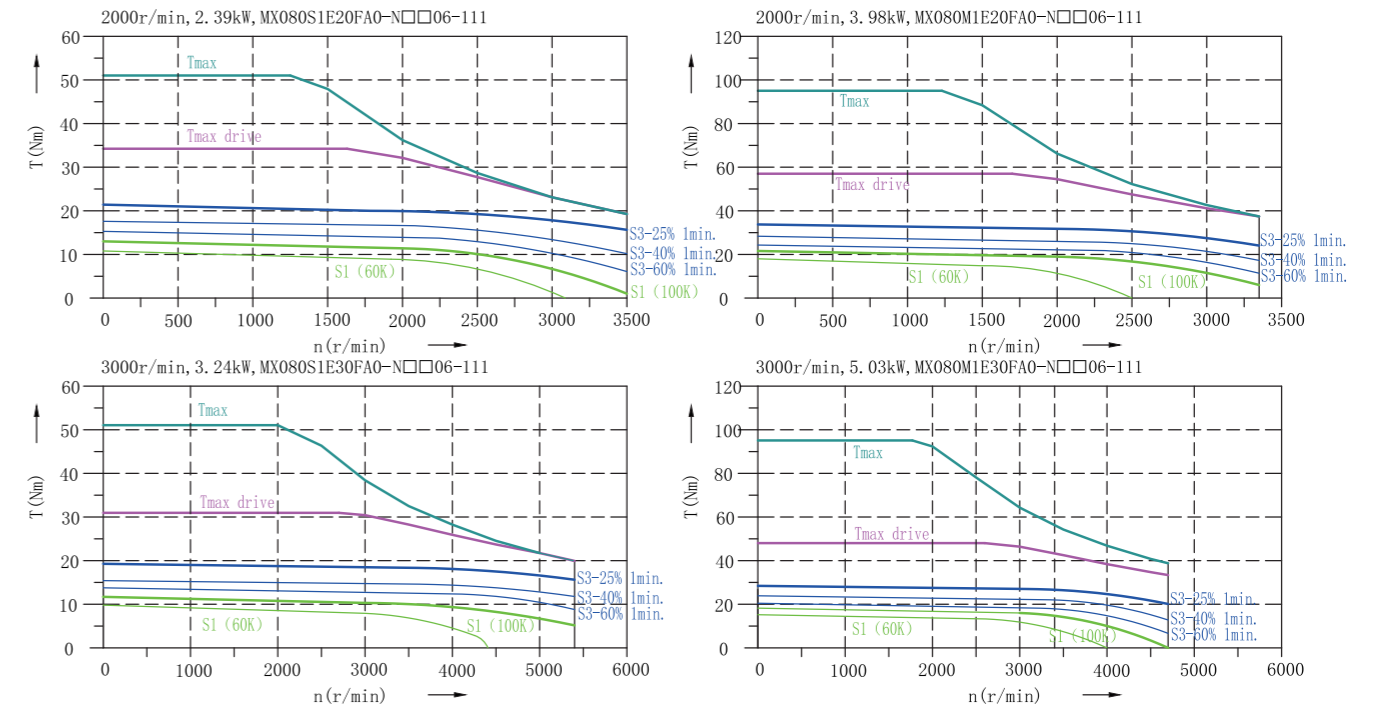
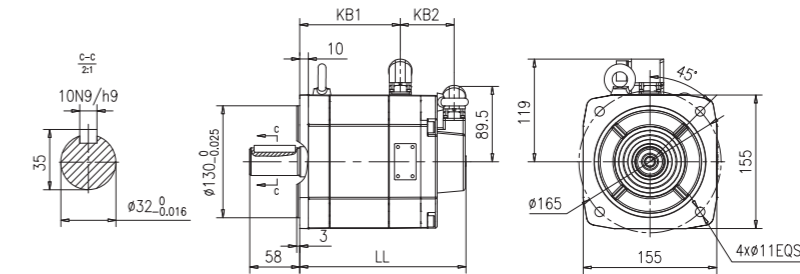

10.6 机座号100伺服马达参数、外形尺寸以及特性曲线

10.6. Frame size 100 servo motor parameters, dimensions and characteristic curve

马达型号	Motor model	MX100S1E15FA0 -N4□06-111	MX100M1E15FA0 -N4□06-111	MX100L1E15FA0 -N4□06-111	MX100S1E20FA0 -N4□06-111
额定转速 n_{IN} (r/min)	Rated speed n_{IN} (r/min)	1500	1500	1500	2000
额定功率 P_{IN} (kW)	Rated power P_{IN} (kW)	4.08	6.6	9.11	5.03
额定电流 $I_{N(100K)}$ (A)	Rated current $I_{N(100K)}$ (A)	8.1	14.5	18.4	10.1
额定转矩 $T_{IN(100K)}$ (N.m)	Rated torque $T_{IN(100K)}$ (N.m)	26	42	58	24
静止电流 I_0 (A)	Static current I_0 (A)	9.4	16.6	21.2	11.8
静止转矩 T_0 (N.m)	Static torque T_0 (N.m)	30	48	66.6	28
最大转速 $n_{max\ drive}$ (r/min)	Maximum speed $n_{max\ drive}$ (r/min)	2550	2750	2500	3400
最大电流 $I_{max\ drive}$ (A)	Maximum current $I_{max\ drive}$ (A)	24.3	43.5	55.2	30.3
最大转矩 $T_{max\ drive}$ (N.m)	Maximum torque $T_{max\ drive}$ (N.m)	78	126	174	72
极限电流 I_{max} (A)	Limit current I_{max} (A)	36.7	67.5	88.7	49.3
极限转矩 T_{max} (N.m)	Limit torque T_{max} (N.m)	117	195	280	117
转动惯量 $J(10^{-4}\text{kg}\cdot\text{m}^2)$	Moment of inertia $J(10^{-4}\text{kg}\cdot\text{m}^2)$	87.49(87.79)	169.96(172.56)	252.43(257.33)	87.49(87.79)
重量 m (kg)	Weight m (kg)	25.6(27)	42.4(47.2)	58.5(63)	25.6(27)
止口到动力连接器长度 KB1(mm)	Socket to Power Connector Length KB1(mm)	144	229	314	144
动力连接器到信号连接器长度 KB2(mm)	Power Connector to Signal Connector Length KB2(mm)	67.2(86.8)	67.2(126.7)	67.2(126.7)	67.2(86.8)
整机长度 LL(mm)	Overall length LL(mm)	225(247)	310(369.5)	395(454.5)	225(247)

注：括号内为带制动器的数据

Note: The data in parentheses are with brake

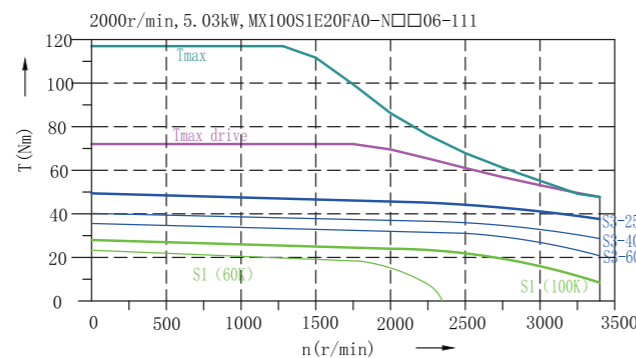
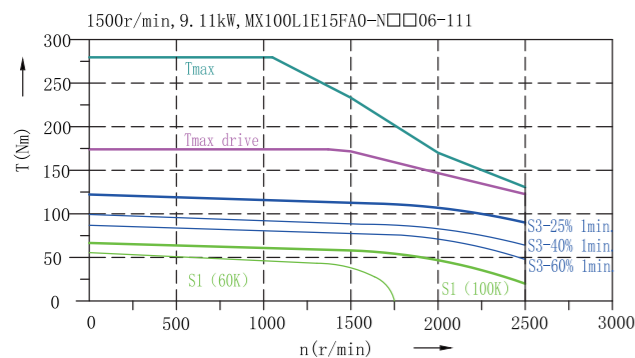
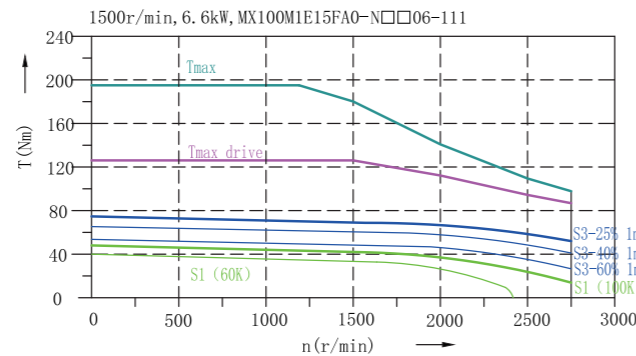
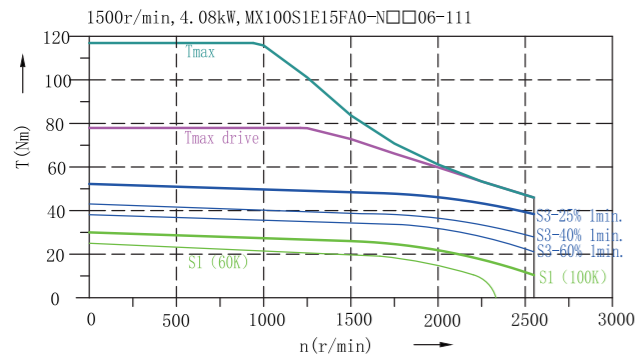
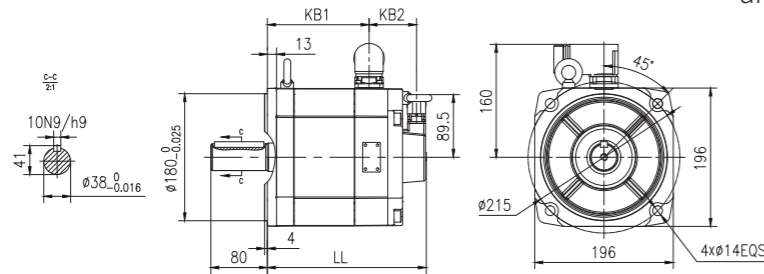

马达型号	Motor model	MX100M1E20FA0 -N4□06-111	MX100L1E20FA0 -N4□06-111	MX100S1E30FA0 -N4□06-111	MX100M1E30FA0 -N4□06-111
额定转速 n_{IN} (r/min)	Rated speed n_{IN} (r/min)	2000	2000	3000	3000
额定功率 P_{IN} (kW)	Rated power P_{IN} (kW)	7.96	10.06	6.28	8.8
额定电流 $I_{N(100K)}$ (A)	Rated current $I_{N(100K)}$ (A)	17.3	19.6	13.8	17.9
额定转矩 $T_{IN(100K)}$ (N.m)	Rated torque $T_{IN(100K)}$ (N.m)	38	48	20	28
静止电流 I_0 (A)	Static current I_0 (A)	19.6	22.5	15.9	20.5
静止转矩 T_0 (N.m)	Static torque T_0 (N.m)	43	55.2	23	32
最大转速 $n_{max\ drive}$ (r/min)	Maximum speed $n_{max\ drive}$ (r/min)	3600	3000	5500	5000
最大电流 $I_{max\ drive}$ (A)	Maximum current $I_{max\ drive}$ (A)	51.9	58.8	41.4	53.7
最大转矩 $T_{max\ drive}$ (N.m)	Maximum torque $T_{max\ drive}$ (N.m)	114	144	60	84
极限电流 I_{max} (A)	Limit current I_{max} (A)	88.9	114.3	80.9	124.9
极限转矩 T_{max} (N.m)	Limit torque T_{max} (N.m)	195	280	117	195
转动惯量 $J(10^{-4}\text{kg}\cdot\text{m}^2)$	Moment of inertia $J(10^{-4}\text{kg}\cdot\text{m}^2)$	169.96(172.56)	252.43(257.33)	87.49(87.79)	169.96(172.56)
重量 m (kg)	Weight m (kg)	42.4(47.2)	58.5(63)	25.6(27)	42.4(47.2)
止口到动力连接器长度 KB1(mm)	Socket to Power Connector Length KB1(mm)	229	314	144	229
动力连接器到信号连接器长度 KB2(mm)	Power Connector to Signal Connector Length KB2(mm)	67.2(126.7)	67.2(126.7)	67.2(86.8)	67.2(126.7)
整机长度 LL(mm)	Overall length LL(mm)	310(369.5)	395(454.5)	225(247)	310(369.5)

注：括号内为带制动器的数据

Note: The data in parentheses are with brake

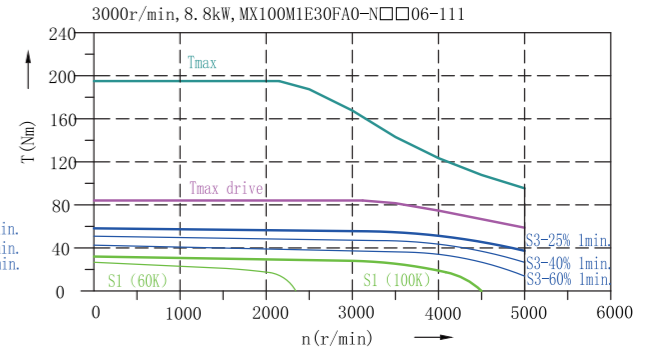
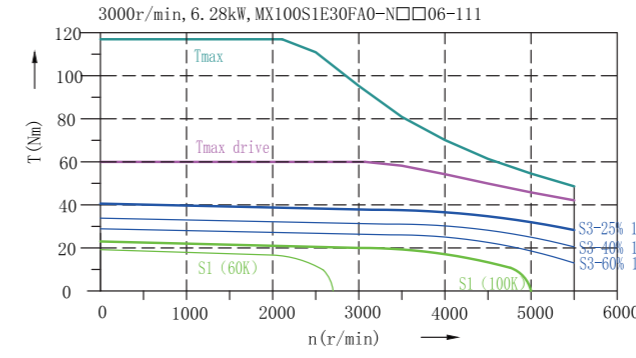
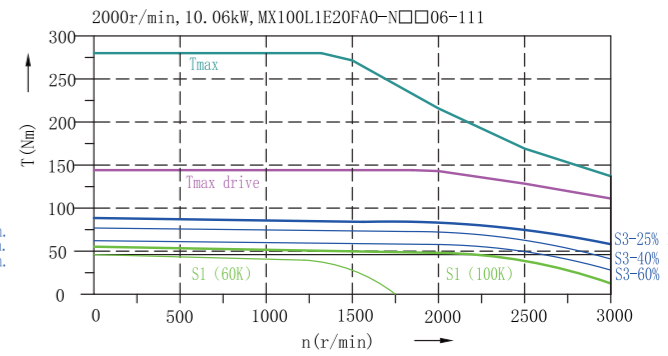
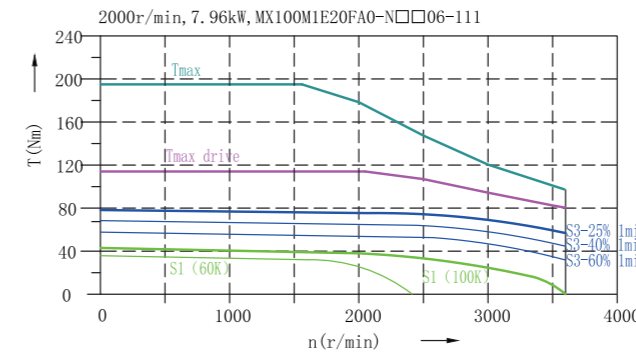
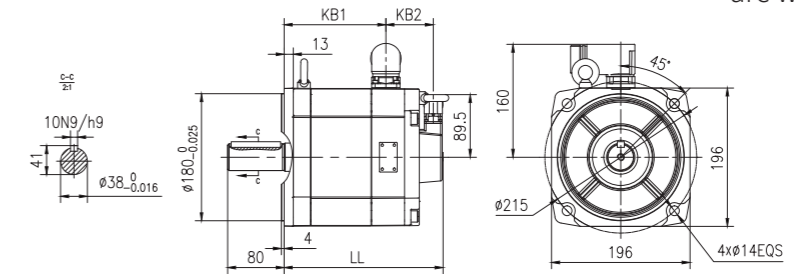

10.7 机座号132伺服马达参数、外形尺寸以及特性曲线

10.7 Frame size 132 servo motor parameters, dimensions and characteristic curve

马达型号	Motor model	MX132M1E12FAO -F4□06-111	MX132M1E15FAO -F4□06-111	MX132M1E18FAO -F4□06-111	MX132M1E20FAO -F4□06-111
额定转速 n_N (r/min)	Rated speed n_N (r/min)	1200	1500	1800	2000
额定功率 P_N (kW)	Rated power P_N (kW)	18	22	26	29
额定电流 I_N (100K) (A)	Rated current I_N (100K) (A)	40	40	40	40
额定转矩 T_N (100K) (N.m)	Rated torque T_N (100K) (N.m)	143.3	140	138	138.5
静止电流 I_0 (A)	Static current I_0 (A)	42	42	42	42
静止转矩 T_0 (N.m)	Static torque T_0 (N.m)	153	150	148	149
最大转速 $n_{max\ inv}$ (r/min)	Maximum speed $n_{max\ inv}$ (r/min)	2300	2300	2300	2300
最大电流 $I_{max\ inv}$ (A)	Maximum current $I_{max\ inv}$ (A)	100	100	100	100
最大转矩 $T_{max\ inv}$ (N.m)	Maximum torque $T_{max\ inv}$ (N.m)	358	350	345	346
转动惯量 J (10^{-4} kg.m ²)	Moment of inertia J (10^{-4} kg.m ²)	740 (870)	740 (870)	740 (870)	740 (870)
重量 m (kg)	Weight m (kg)	120 (136)	120 (136)	120 (136)	120 (136)
整机长度 LL (mm)	Overall length LL (mm)	502 (585)	502 (585)	502 (585)	502 (585)
驱动器供电电压/VAC	Driver supply voltage/VAC	380	430	460	480

注：括号内为带制动器的数据

Note: The data in parentheses are with brake

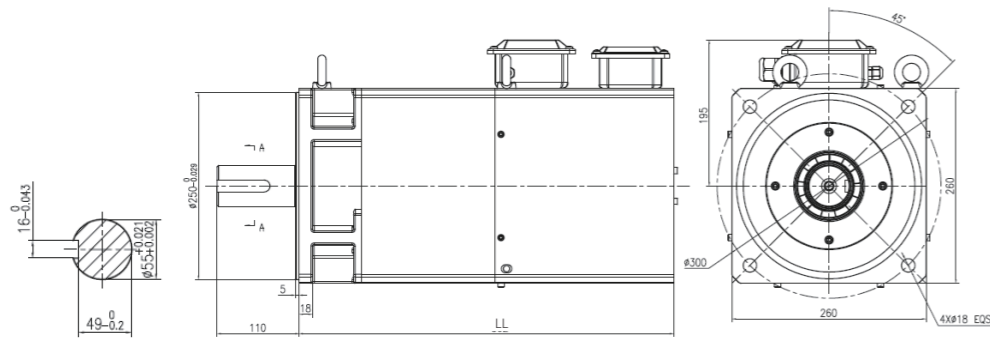

马达型号	Motor model	MX132M1E22FAO -F4□06-111	MX132M1E25FAO -F4□06-111	MX132M1E28FAO -F4□06-111	MX132M1E30FAO -F4□06-111
额定转速 n_N (r/min)	Rated speed n_N (r/min)	2200	2500	2800	3000
额定功率 P_N (kW)	Rated power P_N (kW)	33	37	42	45
额定电流 I_N (100K) (A)	Rated current I_N (100K) (A)	67	67	67	67
额定转矩 T_N (100K) (N.m)	Rated torque T_N (100K) (N.m)	143	141	143	143
静止电流 I_0 (A)	Static current I_0 (A)	71	71	71	71
静止转矩 T_0 (N.m)	Static torque T_0 (N.m)	153	150	153	153
最大转速 $n_{max\ inv}$ (r/min)	Maximum speed $n_{max\ inv}$ (r/min)	3200	3200	3200	3200
最大电流 $I_{max\ inv}$ (A)	Maximum current $I_{max\ inv}$ (A)	168	168	168	168
最大转矩 $T_{max\ inv}$ (N.m)	Maximum torque $T_{max\ inv}$ (N.m)	357	352	357	357.5
转动惯量 J (10^{-4} kg.m ²)	Moment of inertia J (10^{-4} kg.m ²)	740 (870)	740 (870)	740 (870)	740 (870)
重量 m (kg)	Weight m (kg)	120 (136)	120 (136)	120 (136)	120 (136)
整机长度 LL (mm)	Overall length LL (mm)	502 (585)	502 (585)	502 (585)	502 (585)
驱动器供电电压/VAC	Driver supply voltage/VAC	380	430	460	480

注：括号内为带制动器的数据

Note: The data in parentheses are with brake

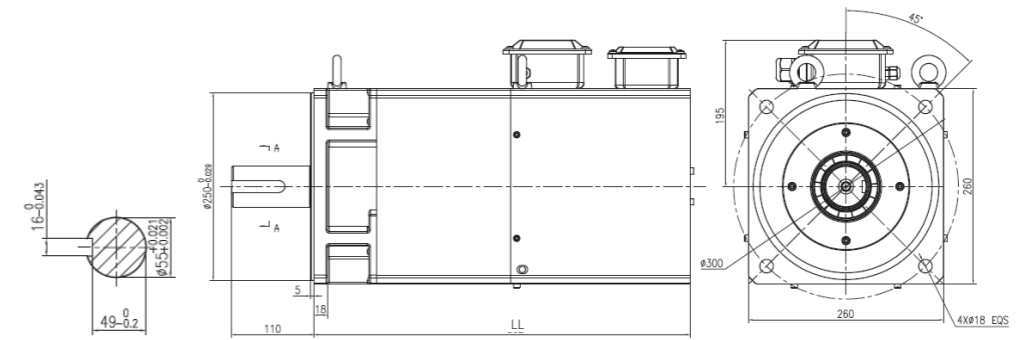

10.8 机座号180伺服马达参数、
外形尺寸以及特性曲线

10.8 Frame size 180 servo motor
parameters, dimensions and
characteristic curve

马达型号	Motor model	MX180M1E08FA0 -F4□06-111	MX180M1E10FA0 -F4□06-111	MX180M1E12FA0 -F4□06-111	MX180M1E14FA0 -F4□06-111
额定转速 n_N (r/min)	Rated speed n_N (r/min)	800	1000	1200	1400
额定功率 P_N (kW)	Rated power P_N (kW)	38	47	57	66
额定电流 $I_{N(100K)}$ (A)	Rated current $I_{N(100K)}$ (A)	85	85	85	85
额定转矩 $T_{N(100K)}$ (N.m)	Rated torque $T_{N(100K)}$ (N.m)	453	448	453	450
静止电流 I_0 (A)	Static current I_0 (A)	90	90	90	90
静止转矩 T_0 (N.m)	Static torque T_0 (N.m)	480	474	480	477
最大转速 $n_{max\ inv}$ (r/min)	Maximum speed $n_{max\ inv}$ (r/min)	1800	1800	1800	1800
最大电流 $I_{max\ inv}$ (A)	Maximum current $I_{max\ inv}$ (A)	212.5	212.5	212.5	212.5
最大转矩 $T_{max\ inv}$ (N.m)	Maximum torque $T_{max\ inv}$ (N.m)	1132.5	1120	1132.5	1125
转动惯量 $J(10^{-4}kg.m^2)$	Moment of inertia $J(10^{-4}kg.m^2)$	4600(5400)	4600(5400)	4600(5400)	4600(5400)
重量 m (kg)	Weight m (kg)	330(360)	330(360)	330(360)	330(360)
整机长度 LL (mm)	Overall length LL (mm)	945(1150)	945(1150)	945(1150)	945(1150)
驱动器供电电压/VAC	Driver supply voltage/VAC	380	430	460	480

注：括号内为带制动器的数据

Note: The data in parentheses are with brake

马达型号	Motor model	MX180M1E15FA0 -F4□06-111	MX180M1E17FA0 -F4□06-111	MX180M1E19FA0 -F4□06-111	MX180M1E21FA0 -F4□06-111
额定转速 n_N (r/min)	Rated speed n_N (r/min)	1500	1700	1900	2100
额定功率 P_N (kW)	Rated power P_N (kW)	74	85	94	103
额定电流 $I_{N(100K)}$ (A)	Rated current $I_{N(100K)}$ (A)	166	166	166	166
额定转矩 $T_{N(100K)}$ (N.m)	Rated torque $T_{N(100K)}$ (N.m)	471	478	472	468
静止电流 I_0 (A)	Static current I_0 (A)	176	176	176	176
静止转矩 T_0 (N.m)	Static torque T_0 (N.m)	499	507	500	496
最大转速 $n_{max\ inv}$ (r/min)	Maximum speed $n_{max\ inv}$ (r/min)	2300	2300	2300	2300
最大电流 $I_{max\ inv}$ (A)	Maximum current $I_{max\ inv}$ (A)	415	415	415	415
最大转矩 $T_{max\ inv}$ (N.m)	Maximum torque $T_{max\ inv}$ (N.m)	1480	1475	1507.5	1512.5
转动惯量 $J(10^{-4}kg.m^2)$	Moment of inertia $J(10^{-4}kg.m^2)$	4600(5400)	4600(5400)	4600(5400)	4600(5400)
重量 m (kg)	Weight m (kg)	330(360)	330(360)	330(360)	330(360)
整机长度 LL (mm)	Overall length LL (mm)	945(1150)	945(1150)	945(1150)	945(1150)
驱动器供电电压/VAC	Driver supply voltage/VAC	380	430	460	480

注：括号内为带制动器的数据

Note: The data in parentheses are with brake

11 马达电气连接

马达电气连接(MX28-100)

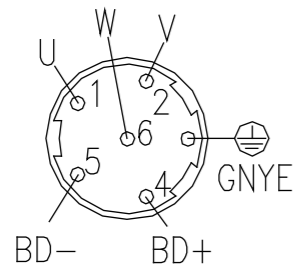

马达动力端插头 (28~80机座) Motor power end plug (28-80)

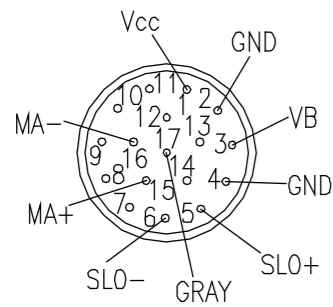

马达信号端插头 (Biss-C编码器) Motor signal end plug (Biss-C encoder)

马达电气连接(MX132-180)

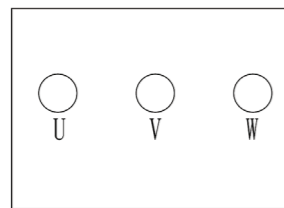

马达动力线接线图 Motor power line wiring diagram

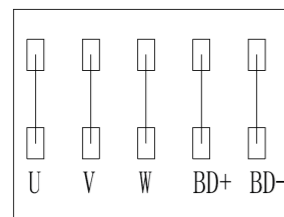

马达风机、制动器电气接线图 Motor fan & brake electrical wiring diagram

11 Motor electrical connection

Motor electrical connection (MX28-100)

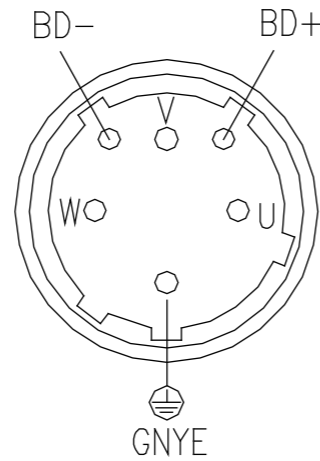

马达动力端插头 (100机座) Motor power end plug (100)

Motor electrical connection (MX132-180)

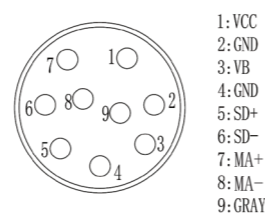

马达编码器接线图 Motor encoder wiring diagram

11.1 旋转连接器

马达上的动力连接器和信号连接器可以在一定范围内旋转。可以使用配套的母插来旋转连接器。母插必须完全插入，以免损坏插针。

11.1 Rotary connector

The power connector and signal connector on the motor can be rotated within a certain range. The connector can be rotated using the mating female socket. The female plug must be fully inserted to avoid damage to the pins.

动力线连接器的旋转范围:

Rotation range of power cable connector:

马达 Motor	角度α1 Angle α1	角度β1 Angle β1	示意图 Schematic
MX028	135°	140°	
MX036	135°	140°	
MX048	135°	140°	
MX063	135°	140°	
MX080	135°	200°	
MX100	135°	200°	

信号线连接器的旋转范围:

Rotation range of signal cable connector:

马达 Motor	角度α1 Angle α1	角度β1 Angle β1	示意图 Schematic
MX028	140°	135°	
MX036	140°	135°	
MX048	143°	135°	
MX063	105°	110°	
MX080	100°	100°	
MX100	95°	95°	

动力/信号接线盒安装方位示意:

Power/Signal Junction Box Installation Orientation Diagram:

马达 Motor	示意图 Schematic
MX132	
MX180	

伺服驱动器

12 驱动器概述

AX精准系列伺服驱动器是专为高性能伺服应用设计的模块化伺服驱动器，搭配CM55/CM53控制模块，和适配不同功率伺服马达的功率模块及一些可选附件组成，灵活的模块化为使用者的系统设计及应用提供更丰富的选择。

AX伺服驱动器配合MX永磁同步伺服马达，可以做到精准的位置、速度、扭矩控制，AX伺服驱动器也可以驱动博能异步马达，实现精确的异步伺服控制。

AX精准系列伺服驱动器由三部分组成：

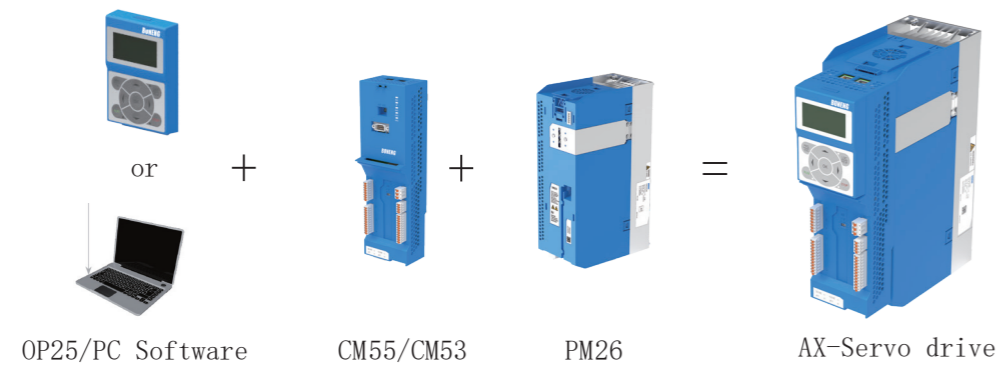

操作面板(OP25)或上位机调试软件 BonengDrivesoft: 操作面板或上位机调试软件可以为用户提供方便快捷的参数设定方法，支持汉字显示，更简单易懂的信息反馈，及高级示波器检测诊断功能。

控制模块(CM53/CM55): 控制模块为用户提供丰富的控制接口，输入输出端子，模拟信号，及通讯等，且通过多种方式可对所接入的马达进行控制和监视。

功率模块(PM26): 书本型功率模块功率范围从0.75kW-132kW，支持多种控制模块，使马达调速变得简单且灵活，且包含了完备的驱动器保护功能。

Servo Drive

12 Servo drive overview

AX precision series servo drive is modular designed for high-performance servo applications, consisting of a CM55/CM53 control module, a power module adapted to different power motors, and some optional accessories. AX series servo drive provides users with richer options for system design and application though its flexible modularization feature.

AX servo drive can achieve accurate position, speed, and torque control when combined with the MX permanent magnet synchronous servo motor, as well as drive the Boneng asynchronous motor to achieve accurate asynchronous servo control.

The AX servo drive consist of three parts:

Operation panel (OP25) or desktop software BongDrivesoft: operation panel and desktop software can provide users with convenient and efficient methods for parameters configuration. The OP25 and BonengDrivesoft can display in English and Chinese, and the BonengDrivesoft can also provide users with advanced functions such as oscilloscope, condition monitoring and diagnosis, and etc.

Control module (CM51/CM55): The control module contains a wealth of control interfaces, input and output terminals, analog signals, and can support communication bus control, which control the motor connected through the Power module.

Power module (PM26) : The power module has a power range from 0.75kW to 132kW, supports a variety of modules, which makes spindle speed adjustment easy and flexible. In addition, complete driver and motor protection functions are available for the power module.

13 驱动器整机安装尺寸图

13 Drive full machine mounting size

13.1 OP25+CM55+PM26

OP25+CM55+PM26组合的整机外形图及安装尺寸图，B1-B6功率范围，单位：mm

13.1 OP25+CM55+PM26

The overall appearance and installation dimension of OP25+CM55+PM26 combination, B1-B6 power range, with unit: mm.

B1(0.75kW-3kW):

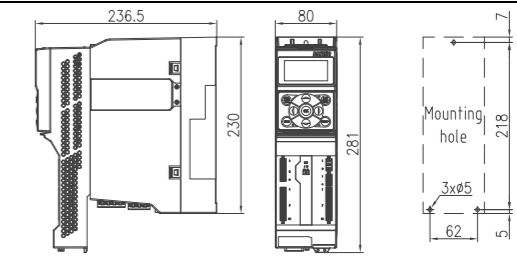

B2(4kW-7.5kW)

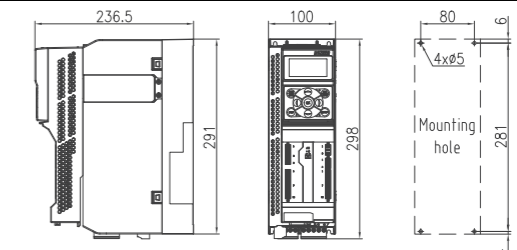

B3(11kW-15kW)

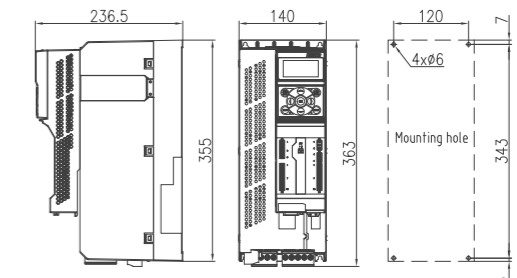

B4(18.5kW-37kW)

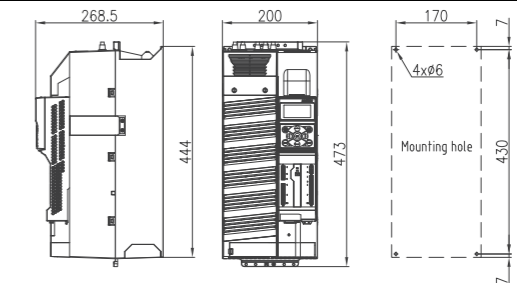

B6(45kW-132kW)

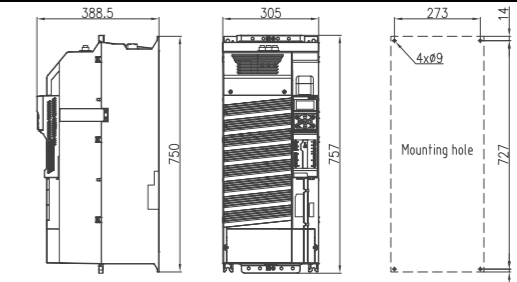

13.2 CM53+PM26

CM53+PM26组合的整机外形图及安装尺寸图, 单位: mm

13.2 CM53+PM26

The overall appearance and installation dimension of CM53+PM26 combination, with unit:mm

B1(0.75kW-3kW):

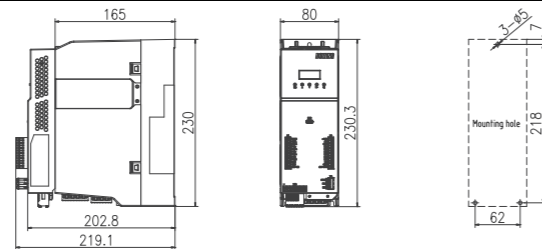

B2(4kW-7.5kW)

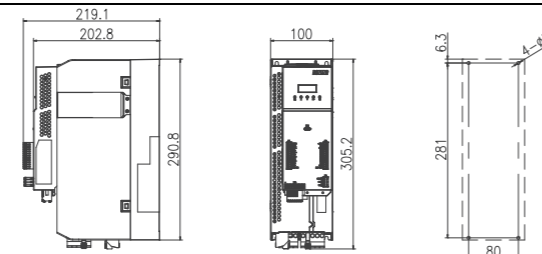

B3(11kW-15kW)

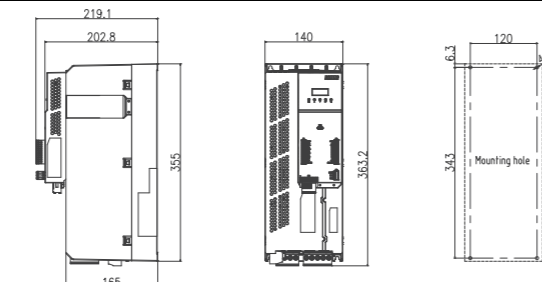

B4(18.5kW-37kW)

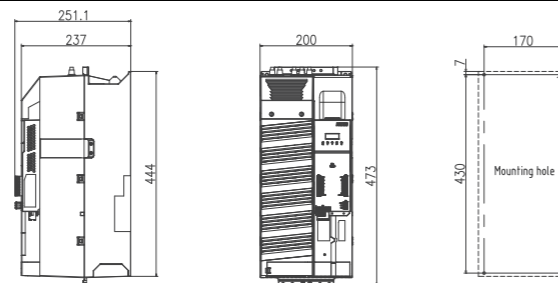

B6(45kW-132kW)

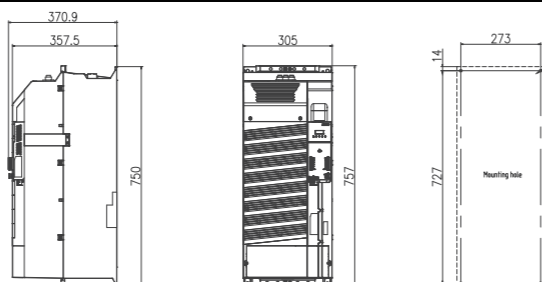

14 驱动器控制模块

14.1 控制模块CM55

14.1.1 概述

CM55模块是专为总线型伺服系统应用而设计的控制模块, 支持EtherCAT及PROFINET通讯, PROFINET通讯支持RT及IRT应用, 除了标准的同步伺服电机为还支持异步伺服定位。

14 Control module

14.1 Control module CM55

14.1.1 Information

The CM55 module is a control module designed specifically for bus type servo system applications, supporting EtherCAT and PROFINET communication. PROFINET communication supports RT and IRT applications, and in addition to standard synchronous servo motors, it also supports asynchronous servo positioning.



CM55控制模块

CM55 control module

14.1.2 控制模块型号表示方法

14.1.2 Designation rules and nameplate for control module

博能精准系列伺服驱动器

控制模块

通讯协议

EA=EtherCAT及博能自定义通讯DriveLink
PA=PROFINET及博能自定义通讯DriveLink

编码器接口

PE=增量式/绝对值编码器

Boneng AX-series precision servo drive

Control module

Communication protocol

EA=EtherCAT and Boneng defined DriveLink.
PA=PROFINET and Boneng defined DriveLink

Encoder Interface

PE=photoelectric incremental /absolute encoder

AX-CM55-PA-PE

控制模块订货号

Control module order number

型号 Model	接口类型描述	Interface type description
AX-CM55-EA-PE	支持EtherCAT及博能自定义DriveLink通讯, 增量/绝对式光电编码器	Support EtherCAT and Boneng defined DriveLink, incremental /absolute optical encoder.
AX-CM55-PA-PE	支持PROFINET及博能自定义DriveLink通讯, 增量/绝对式光电编码器	Support PROFINET and Boneng defined DriveLink, incremental /absolute optical encoder.

14.1.3 控制模块技术参数

14.1.3 Technical date

功能	Functions			技术数据	Technical data
总线接口	Bus interface	AX-CM55-PA-PE	AX-CM55-PA-PE	<ul style="list-style-type: none"> 支持PROFINET、DriveLink RJ45接口 	<ul style="list-style-type: none"> PROFINET, DriveLink bus RJ45 interface
		AX-CM55-EA-PE	AX-CM55-EA-PE	<ul style="list-style-type: none"> 支持EtherCAT、DriveLink RJ45接口 	<ul style="list-style-type: none"> EtherCAT, DriveLink bus RJ45 interface
工作电源	Power supply	功率模块供电	By power module	<ul style="list-style-type: none"> 数字量输入/输出端子作为输出使用时需外接24V电源 	<ul style="list-style-type: none"> DI/DO terminal as an output, an external 24v power supply is required
		外部端子供电	By external terminals	<ul style="list-style-type: none"> 电压范围: DC 20.8 ~ 28.8V 最大电流: 2.6A 	<ul style="list-style-type: none"> Voltage range: DC 20.8 ~ 28.8V Maximum current: 2.6A
输出电源	Power output	+24V输出	+24V output	<ul style="list-style-type: none"> 电压范围: DC 18V ~ 26.8V 最大电流: 200mA 	<ul style="list-style-type: none"> Voltage range: DC 18V ~ 26.8V Maximum current: 200mA
		+10V输出	+10V output	<ul style="list-style-type: none"> 电压范围: DC 9.5V ~ 10.5V 最大电流: 40mA 	<ul style="list-style-type: none"> Voltage range: DC 9.5V ~ 10.5V Maximum current: 40mA
		DB15接口编码器电源	DB15 encoder power supply	<ul style="list-style-type: none"> 电压: DC 5V或DC 24V 最大电流: 350mA 	<ul style="list-style-type: none"> Voltage: DC 5V or DC 24V Maximum current: 350mA
		RJ45接口编码器电源	RJ45 encoder power supply	<ul style="list-style-type: none"> 电压: DC 5V 最大电流: 200mA 	<ul style="list-style-type: none"> Voltage: DC 5V Maximum current: 200mA
数字量输入	Digital input	11个 (DIO [~] DI10)	11 (DIO [~] DI10)	<ul style="list-style-type: none"> DI1、DI3、DI5、DI7 为非公共端子类型 DI0、DI2、DI4、DI6 公共端子DICO0 DI8、DI9、DI10公共端子DICO1 电气隔离 支持Source和Sink模式 电压: DC 24V、AC 36V "1"信号电压: >11V "0"信号电压: <5V 24V典型电流: 4mA 响应时间: 6ms (含软件滤波) 	<ul style="list-style-type: none"> Differential inputs: DI1、DI3、DI5、DI7 Single inputs: DI0、DI2、DI4、DI6 share DICO0 Single inputs: DI8、DI9、DI10 share DICO1 Electrical isolation Support Source and Sink mode Voltage: DC 24V, AC 36V Level "1" voltage: >11V Level "0" voltage: <5V 24V typical current: 4mA Response time: 6ms(Including software filter)
数字量输出	Digital output	1个继电器 (DO0)	1 relay (DO0)	<ul style="list-style-type: none"> 电压: DC 24V、AC 220V 连续电流: 2A 切换电流: 2A 触点类型: 1常开1常闭 	<ul style="list-style-type: none"> Voltage: DC 24V、AC 220V Continuous current: 2A Switching current: 2A Contact type: 1 normally open and 1 close
数字量输入/输出	Bidirectional digital input and output	8个 (DIO20 [~] DI027)	8 (DIO20 [~] DI027)	<ul style="list-style-type: none"> 电压: 最大DC 30V 电流: 输出最大200mA, 24V输入典型4mA 频率: 最大100Hz 输入"1"信号电压: >15V 输入"0"信号电压: <5V 非电气隔离 外部供电端子需接24V 	<ul style="list-style-type: none"> Voltage: DC 30V maximum Current: output 200mA maximum, 24V input typical 4mA Frequency: 100Hz maximum Input level "1" voltage: >15V Input level "0" voltage: <5V Non-electrically isolated 24V power supply is needed for DIO

功能	Functions			技术数据	Technical data
模拟量输入	Analog input	1个 (AIO)	1 (AIO)	<ul style="list-style-type: none"> 差分输入 拨码开关切换电压和电流模式 电压型支持-10V ~ +10V、0V ~ 10V 电流型支持0mA ~ 20mA、4mA ~ 20mA 电流型内阻250Ω 响应时间: 2ms (含软件滤波) 精度: ±1% 	<ul style="list-style-type: none"> Differential input Dip switch to choose voltage and current mode Voltage range(voltage mode): -10V~+10V、0V~10V Current range(current mode): 0mA~20mA、4mA~20mA Internal resistance in current mode: 250Ω Response time: 2ms(including software filter) Precision: ±1%
温度传感器	Temperature sensor	2个	2	<ul style="list-style-type: none"> 分别位于端子X5和X11 支持KTY84-130、PTC 	<ul style="list-style-type: none"> Respectively at the X5and X11 Support KTY84-130、PTC
编码器信号输入	Encoder interface		ABZ	<ul style="list-style-type: none"> 支持24V的单端信号、5V和24V的差分信号 输入频率: 最大250kHz 断线侦测: 仅支持差分类型 最大长度: 5V差分类型100m 24V开集电极类型50m 24V推挽类型100m 24V差分类型300m 	<ul style="list-style-type: none"> 24V single-ended signal.5V and 24V differential signal Input frequency:250kHz maximum Disconnection detection: only support differential mode Maximum wire length: 5V differential mode: 100m 24V open-collector type: 50m 24V push-pull: 100m 24V differential mode: 300m
			BISS-C	<ul style="list-style-type: none"> 波特率: 最大4Mbps 最大长度: 500kbps时100m 	<ul style="list-style-type: none"> Baud rate: 4Mbps maximum Maximum wire length:100m at 500kbps
			RS485	<ul style="list-style-type: none"> 波特率: 最大2.5Mbps 最大长度: 500kbps时100m 	<ul style="list-style-type: none"> Baud rate: 2.5 Mbps maximum Maximum wire length:100m at 500kbps
USB接口	USB interface	1个	1	<ul style="list-style-type: none"> USB 2.0 Mini-B 	<ul style="list-style-type: none"> USB 2.0 Mini-B
指示灯	Status LEDs	2个双色指示灯	2two-color LEDs	<ul style="list-style-type: none"> RDY指示灯: 红绿双色 BF指示灯: 红绿双色 	<ul style="list-style-type: none"> RDY LED: red and green BF LED: red and green
		3个单色指示灯	3single-color LEDs	<ul style="list-style-type: none"> SAFE指示灯: 黄色 LNK1指示灯: 绿色 LNK2指示灯: 绿色 	<ul style="list-style-type: none"> SAFE LED: yellow LNK1 LED: green LNK2 LED: green
键盘接口	Keyboard interface	支持OP25	OP25 supported	<ul style="list-style-type: none"> 可直接安装或外引安装 	<ul style="list-style-type: none"> Install directly or external with extension cable
工作温度	Use ambient temperature	-20℃ ~ +50℃	-20℃ ~ +50℃		
存储温度	Storage temperature	-40℃ ~ +70℃	-40℃ ~ +70℃		
相对空气湿度	Environment humidity	<95%	<95%	不允许有凝露	Condensation prohibited
污染	Pollution	符合IEC 61800-5-1	IEC 61800-5-1	适用于污染等级2的环境	Pollution degree: level 2
电磁兼容性	Electromagnetic compatibility	符合IEC 61800-3	IEC 61800-3		

14.1.4 控制模块电气连接

14.1.4 Control module wiring

14.1.4.1 控制模块接线示意图

14.1.4.1 Control module wiring example

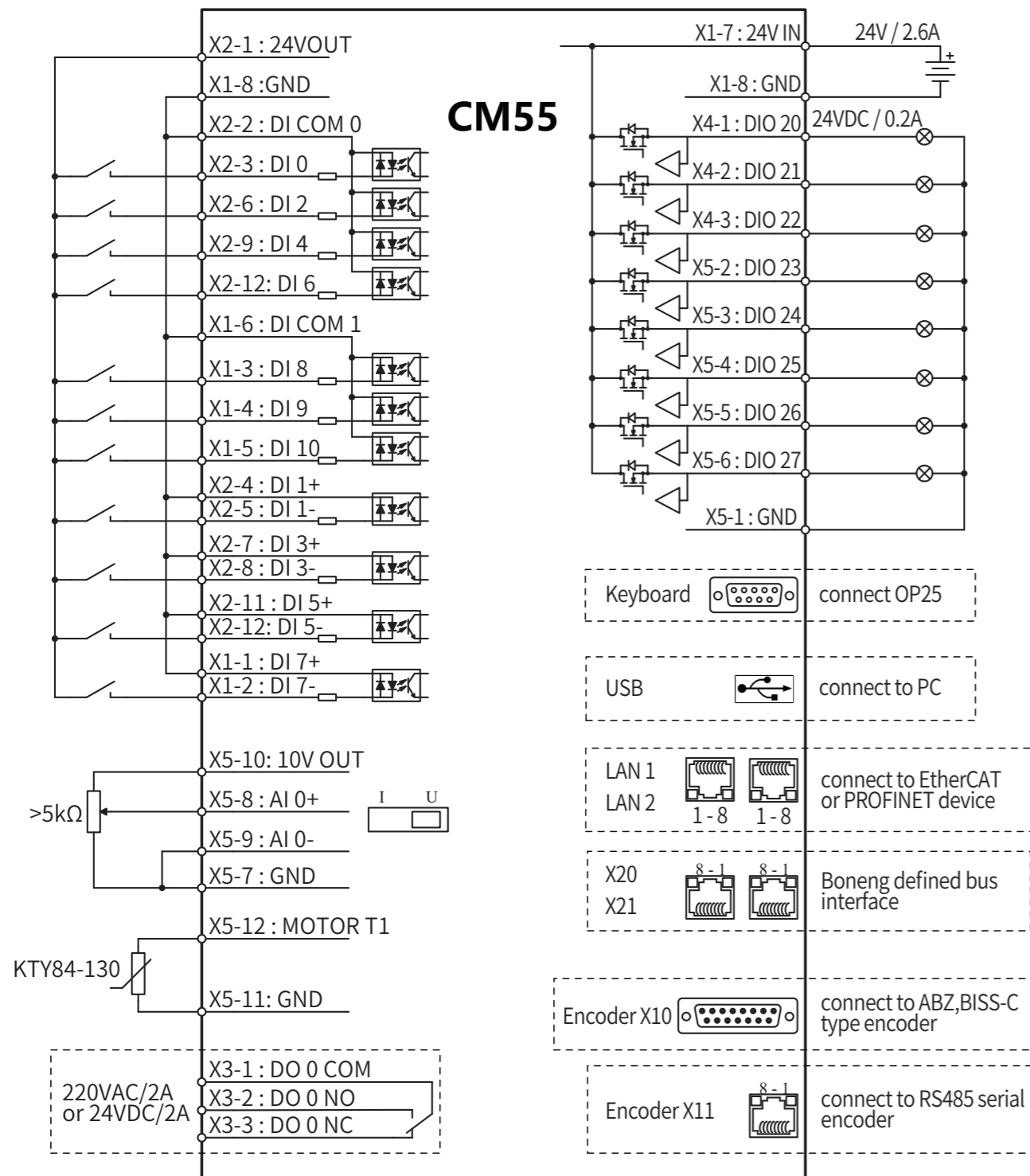

14.1.4.2 编码器接口信号定义

14.1.4.2 Encoder interface

a) 编码器接口(X10)信号定义

a) Encoder interface(X10) signals

Pin.	信号说明	Signal description
1	BISS-C的数据+	BISS-C data+
2	BISS-C的时钟+	BISS-C clock+
3	BISS-C的时钟-	BISS-C clock-
4	编码器电源(5V或24V)	Encoder power supply(5V or 24V)
5	编码器电源(5V或24V)	Encoder power supply(5V or 24V)
6	编码器电源侦测输入	Encoder power detection input
7	电源地	Power ground
8	BISS-C的数据-	BISS-C data-
9	编码器电源侦测输入接地	Encoder power detection ground
10	增量式信号Z+	Incremental type Z+
11	增量式信号Z-	Incremental type Z-
12	增量式信号B-	Incremental type B-
13	增量式信号B+	Incremental type B+
14	增量式信号A-	Incremental type A-
15	增量式信号A+	Incremental type A+

b) 编码器接口(X11)信号定义

b) Encoder interface(X11) signals

Pin.	信号说明	Signal description
1	KTY84-130或PTC输入	KTY84-130/PTC input
2	KTY84-130或PTC的接地	KTY84-130/PTC ground
3	BISS-C信号CK+	BISS-C signal CK+
4	RS485信号B或BISS-C信号DA-	RS485 signal B / BISS-C signal DA-
5	RS485信号A或BISS-C信号DA+	RS485 signal A / BISS-C signal DA+
6	BISS-C信号CK-	BISS-C signal CK-
7	编码器电源(5V)	Encoder power supply(5V)
8	编码器电源地	Power ground

14.2 控制模块CM53

14.2.1 概述

CM53模块是专为总线型伺服系统应用而设计的控制模块，支持PROFINET通讯，支持RT及IRT应用，除了标准的同步伺服电机为还支持异步伺服定位。



14.2.2 控制模块型号表示方法

博能精准系列伺服驱动器
控制模块
通讯协议
编码器
PE=增量式/绝对值编码器

Boneng AX-series precision servo drive
Control module
Communication protocol
Encoder Interface
PE=photoelectric incremental /absolute encoder

AX-CM53-PA-PE

订货号

Order number

型号 Model	接口类型描述	Interface type description
AX-CM53-PA-PE	支持PROFINET通讯，增量/绝对式光电编码器	Support PROFINET, incremental / absolute optical encoder

14.2 Control module CM53

14.2.1 Information

The CM53 module is a control module designed specifically for bus type servo system applications, supporting PROFINET communication, supports RT and IRT applications, and in addition to standard synchronous servo motors, it also supports asynchronous servo positioning.

14.2.2 Designation rules and nameplate for control module

14.2.3 技术参数

14.2.3 Technical data

功能 Functions	技术数据 Technical data	技术数据 Technical data	14.2.3 技术参数	14.2.3 Technical data
总线接口 Bus interface	AX-CM53-PA-PE	AX-CM53-PA-PE	•支持PROFINET、DriveLink •RJ45接口	•PROFINET, DriveLink bus •RJ45 interface
工作电源 Power supply	功率模块供电	By power module	•DC 24V/1.0A	•DC 24V/1.0A
	外部端子供电	By external terminals	•电压范围: DC 20.8 ... 28.8V •最大电流: 1.0A	•Voltage range: DC 20.8 ~28.8V •Maximum current: 1.0A
输出电源 Power output	+24V输出	+24V output	•电压范围: DC 18V ... 26.8V •最大电流: 100mA	•Voltage range: DC 18V ... 26.8V •Maximum current: 100mA
	+10V输出	+10V output	•电压范围: DC 9.5V ... 10.5V •最大电流: 10mA	•Voltage range: DC 9.5V ... 10.5V •Maximum current: 10mA
数字量输入 Digital input	6个	6	•DI0、DI1 ... DI5共公共端子MO •电气隔离 •支持Source和Sink模式 •电压: DC 24V、AC 36V •“1”信号电压: >11V •“0”信号电压: <5V •24V典型电流: 4mA •响应时间: 6ms (含软件滤波)	•Single inputs: DI0, DI1 ... DI5 share MO •Electrical isolation •Support Source and Sink mode •Voltage: DC 24V, AC 36V •Level “1” voltage: >11V •Level “0” voltage: <5V •24V typical current: 4mA •Response time: 6ms (Including software filter)
数字量输出 Digital output	1个继电器(DO0)	1 relay (DO0)	•电压: DC 24V、AC 220V •连续电流: 2A •切换电流: 2A •触点类型: 1常开1常闭	•Voltage: DC 24V, AC 220V •Continuous current: 2A •Switching current: 2A •Contact type: 1 normally open and 1 close
脉冲输出 Pulse output	3个(POA ~ POZ)	3 (POA ~ POZ)	•电压: DC 5V •电流: 最大20mA •频率: 最大2MHz •差分输出 •Z相支持开集电极输出	•Voltage: DC 5V •Current: Maximum 20mA •Frequency: Maximum 2MHz •Differential output •Z-phase supports open collector output
模拟量输入 Analog input	1个(AIO)	1 (AIO)	•电子开关切换电压和电流模式 •电压型支持0V ... 10V •电流型支持0mA ... 20mA, 4mA ... 20mA •电流型内阻500Ω •响应时间: 2ms (含软件滤波) •精度: ±1%	•Electronic switch to choose voltage and current mode •Voltage range (voltage mode): 0V ~ 10V •Current range (current mode): 0mA ~ 20mA, 4mA ~ 20mA •Internal resistance in current mode: 500Ω •response time: 2ms (including software filter) •Precision: ±1%
温度传感器 Temperature sensor	1个	1	•位于RJ45编码器端子X11 •支持KTY84-130、PTC	•Respectively at the X11 •Support KTY84-130, PTC

功能	Functions	技术数据	Technical data
编码器信号输入 Encoder interface		ABZ	<ul style="list-style-type: none"> 支持24V或5V的差分信号 输入频率: 最大250kHz 最大长度: 100m 断线侦测功能
		SSI	<ul style="list-style-type: none"> 支持5V的差分信号 波特率: 最大1Mbps
		BISS-C	<ul style="list-style-type: none"> 波特率: 最大2.5Mbps RJ45接口 最大长度: 500kbps时 50m
		RS485	<ul style="list-style-type: none"> 波特率: 最大2.5Mbps 最大长度: 500kbps时 50m
USB接口	USB interface	1个	1
键盘显示	Keyboard display	支持	support
工作温度	Ambient temperature	-20°C ... +50°C	-20°C ... +50°C
存储温度	Storage temperature	-40°C ... +70°C	-40°C ... +70°C
相对空气湿度	Environment humidity	<95%	<95%
污染	Pollution	符合IEC 61800-5-1	适用于污染等级2的环境
电磁兼容性	Electromagnetic compatibility	符合IEC 61800-3	IEC 61800-3
重量	Weight	大约635g	Approximately 635g

14.2.4 控制模块电气连接

14.2.4.1 控制模块接线示意图

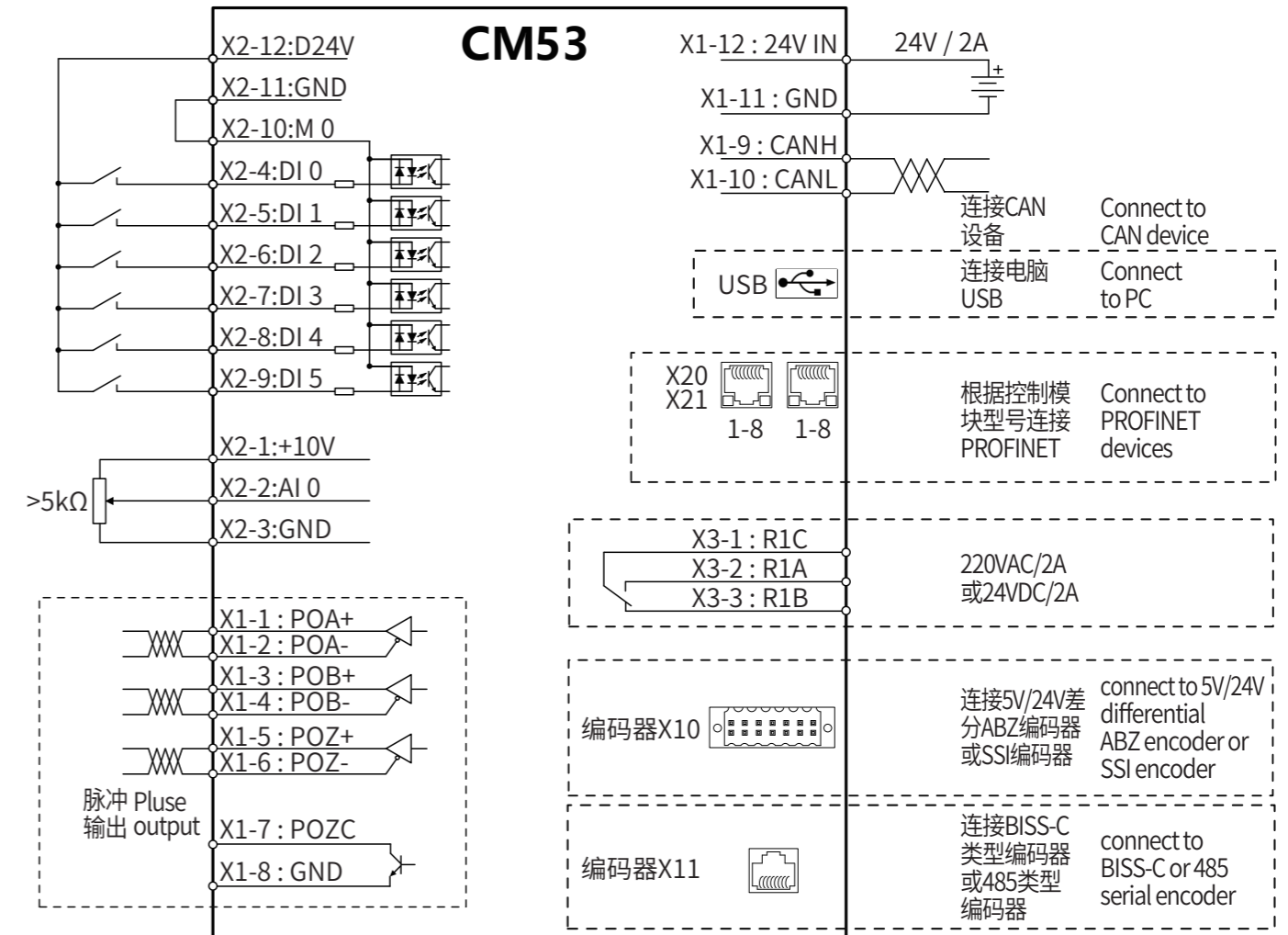

14.2.4 Control module wiring

14.2.4.1 Control module wiring example

14.2.4.2 编码器接口信号定义:

a) 编码器接口(X10)信号定义

14.2.4.2 Encoder interface

a) Encoder interface (X10) signals

	Pin.	信号说明	Signal description
	1	增量式编码器信号A+	Incremental type A+
	2	增量式编码器信号A-	Incremental type A-
	3	增量式编码器信号B+	Incremental type B+
	4	增量式编码器信号B-	Incremental type B-
	5	增量式编码器信号Z+	Incremental type Z+
	6	增量式编码器信号Z-	Incremental type Z-
	7	编码器电源 (5V/0.2A)	Encoder power supply (5V/0.2A)
	8	编码器电源地	Power ground
	9	编码器电源 (24V/0.2A)	Encoder power supply (24V/0.2A)
	10	编码器电源地	Power ground
	11	SSI编码器信号CK+	SSI signal CK +
	12	SSI编码器信号CK-	SSI signal CK -
	13	SSI编码器信号DA+	SSI signal DA+
14	SSI编码器信号DA-	SSI signal DA-	

b) 编码器接口(X11)信号定义

b) Encoder interface (X11) signals

	Pin.	信号说明	Signal description
	1	KTY84-130或PTC输入	KTY84-130 / PTC input
	2	KTY84-130或PTC接地	KTY84-130 / PTC ground
	3	BISS-C信号CK+	BISS-C signal CK+
	4	RS485信号B或BISS-C信号DA-	RS485 signal B / BISS-C signal DA-
	5	RS485信号A或BISS-C信号DA+	RS485 signal A / BISS-C signal DA+
	6	BISS-C信号CK-	BISS-C signal CK-
	7	编码器电源(5V)	Encoder power supply (5V)
8	编码器电源地	Power ground	

15 驱动器功率模块

15.1 功率模块概述

伺服驱动器功率模块AX-PM26的功率范围为0.75kW-132kW,可适配博能MX系列伺服马达,用户无需担心MX伺服马达和AX-PM26的选型匹配问题,只需要按样本前面章节中厂家推荐的默认选型匹配表进行匹配即可。AX-PM26伺服功率模块匹配AX-CM55/CM53伺服控制模块,构成了博能精准定位的伺服驱动器。

15.2 功率模块型号表示方法

博能精准系列伺服驱动器

功率模块

电压等级

B=400V AC

输入相数

3=三相输入 3φ

功率代号

内置滤波器代号

N=不带内置滤波器代号

F=带内置滤波器代号

Boneng AX-series precision servo drive

Power module

Voltage level

B=400V AC

Num.input phases

3=Three-phases input 3φ

Power id

Built-in filter id

N=Without built-in filter

F=With built-in filter

15 Power module

15.1 General information

The power module AX-PM26 has a power range from 0.75 kW to 132 kW, can be adapted to the MX-series motor, which makes it easily for users to choose motor and AX-PM26(just select as what recommended in the default model matching table) without worrying about matching problems. The AX-PM26 can be matched to AX-CM55/CM53 to form a precisely positioned servo drive.

15.2 Designation rules and nameplate for power module

AX-PM26-B 3-A75-N

功率模块订货数据

Power module order number

380...480V 3AC输入				380...480V 3AC input	
额定数据		Rated data		外形 Dimension 尺寸 type	型号 Model
额定功率 (kW)	Rated Power (kW)	额定电流 (A)	Rated Current (A)		
0.75		1.25		B1	AX-PM26-B3A75-N
1.5		2.42			AX-PM26-B3B15-N
2.2		3.43			AX-PM26-B3B22-N
3		4.51		B2	AX-PM26-B3B30-N
4		5.93			AX-PM26-B3B40-N
5.5		7.69			AX-PM26-B3B55-N
7.5		10.53		B3	AX-PM26-B3B75-N
11		15.2			AX-PM26-B3C11-N
15		18.71			AX-PM26-B3C15-N
18.5		38		B4	AX-PM26-B3C18-N
22		45			AX-PM26-B3C22-N
30		60			AX-PM26-B3C30-N
37		75		B6	AX-PM26-B3C37-N
45		90			AX-PM26-B3C45-N
55		110			AX-PM26-B3C55-N
75		145			AX-PM26-B3C75-N
90		178			AX-PM26-B3C90-N
110		190			AX-PM26-B3D11-N
132		202		AX-PM26-B3D13-N	

注:带内置滤波器的功率模块PM26无现货库存,如需要,请咨询厂家。

Note: PM26 with built-in filter is out of stock, contact us if need.

15.3 功率模块电气连接

15.3 Power module wiring

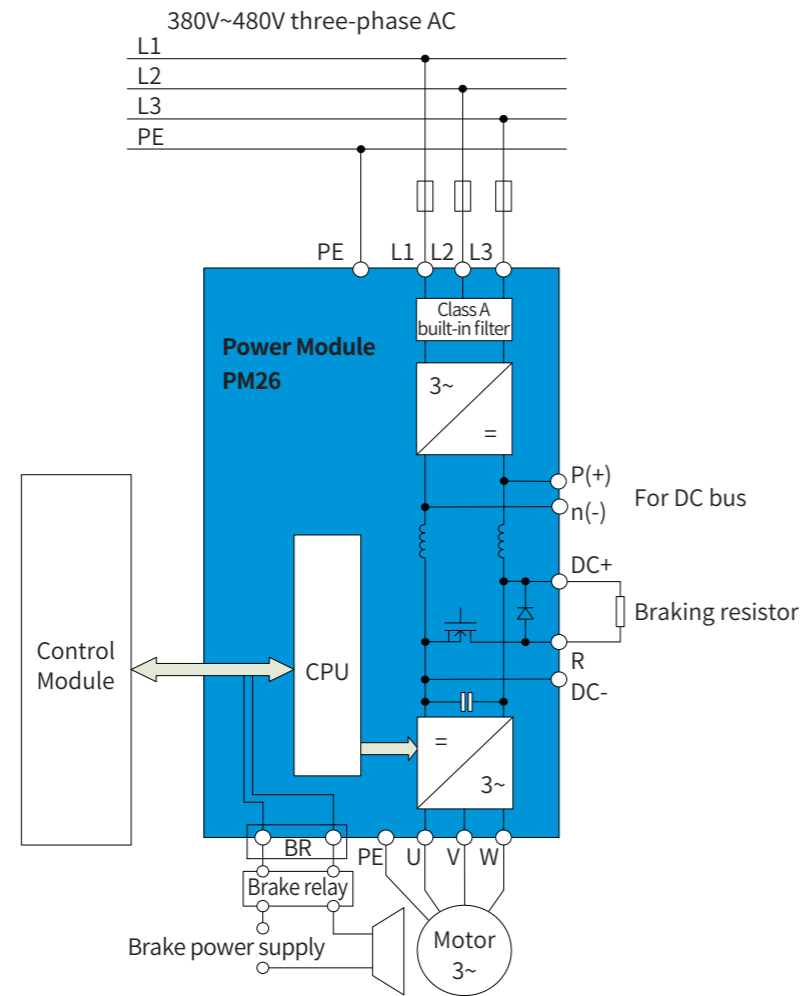

注：PM26的BR接口仅在配合控制模块CM55时可用，配合控制模块CM51时不可用，可以接端子上的继电器来控制抱闸。

Note: The BR interface of PM26 is only available when working with control module CM55, but not when working with control module CM51. It can be connected to a relay on the terminal to control the holding brake.

15.4 功率模块通用技术参数

15.4 General technical data for power module

		PM26功率模块（通用参数）	PM26 power module(general parameters)
输入电压	Voltage input	380...480V 3AC ±10%	380...480V 3AC ±10%
输入频率	Input frequency	47...63Hz	47...63Hz
默认载波频率	Default carrier frequency	变频模式：90kW及以下4kHz, 110kW及以上2kHz	Frequency conversion mode: 4 kHz for 90 kW and below; 2 kHz for 110 kW and above.
		伺服模式：15kW及以下8kHz, 18.5kW及以上为4kHz	Servo mode: 8kHz for 15kW and below; 4kHz for 18.5kW and above.
功率因数	Power factor	0.95	0.95
驱动器效率	Drive efficiency	95...97%	95...97%
过载能力	Overload capacity	在30s周期性冲击负载下, 可实现3倍3s的过载能力	Under 30s periodic impact load, can withstand 3 times the overload for 3s.
电磁兼容	Electromagnetic compatibility	可选符合EN 55011标准的A级滤波器和B级滤波器	Optional A-level and B-level filters complying with EN 55011.
可选制动方式	Optional braking method	• DC制动	直流电流制动, 制动力有限
		• 外挂制动单元	直流母线上外接制动单元, 或外挂回馈单元制动
		• 内置制动斩波器, 需外接制动电阻	DC current braking, with limited braking force. External braking unit on DC bus, or external feedback unit braking. Built-in braking chopper, external resistor is required.
防护等级	Protection level	IP20	IP20
工作温度	Use ambient temperature	-20...+40℃无需降额; +40℃...+50℃每升高1℃降额1.5%; +50℃...+60℃每升高1℃降额5%	-20~+40C: no derating; +40C~+50C: decrease by 1.5% for every 1C increase; +50C~+60C: decrease by 5% for every 1C increase.
存储温度	Storage temperature	-40...+70℃	-40...+70℃
相对湿度	Relative humidity	<95% RH, 无结露	<95% RH, no condensation
冷却方式	Cooling method	内部风冷	功率部分采用内置风扇强制风冷
安装海拔高度	Installation altitude	海拔1000m以下无需降额; 1000m...4000m每升高100m降额1%	No derating within 1000m; 1000m~4000m: decrease by 1% for every 100m rise in altitude
标准SCCR	Standard SCCR	小于100kA	Less than 100kA
保护功能	Protective function	• 欠电压	• Under voltage
		• 过电压	• Over voltage
		• 过载	• Overload
		• 接地故障	• Ground fault
		• 短路	• Short-circuit
		• 马达抱闸保护	• Motor braking protection
		• 马达过温	• Motor over temperature
		• 输出缺相	• Output phase loss
• 变频器过温	• Inverter over temperature		

15.5 功率模块详细技术参数

15.5 Detailed technical parameters

		进线电压380...480V 3AC						Incoming line voltage 380...480V 3AC								
技术参数		Technical data		AX-PM26-B3A75	AX-PM26-B3B15	AX-PM26-B3B22	AX-PM26-B3B30	AX-PM26-B3B40	AX-PM26-B3B55	AX-PM26-B3B75						
额定输出功率 kW		Rated output power kW		0.75	1.5	2.2	3	4	5.5	7.5						
额定输入电流	Rated output current	带进线电抗器A With incoming line reactorA		2.3	4.3	6.1	8	10.4	15.3	18.7						
		不带进线电抗器A Without incoming line reactorA		2.6	4.9	7.6	10.2	13.4	17.2	21.9						
额定输出电流 A		Rated output current A		1.25	2.42	3.43	4.51	5.93	7.69	10.53						
效率 η		Efficiency η		>0.95												
功率损失kW		Power loss kW		0.1	0.11	0.14	0.16	0.18	0.24	0.3						
冷却风量要求 m³/s		Cooling air requirement m³/s		0.005			0.024			0.055						
噪声水平 dB(A)		Noise level dB(A)		<40				<50								
控制单元接口		Interface with control unit		1												
制动电阻连接电缆的最大长度m		Maxi mum cable length of braking resistor m		15												
进线电源连接	Power supply wiring	L1、L2、L3		螺钉端子 Screw terminal												
		电缆截面积mm² Cable sectional Aera mm²		1...2.5				2.5...6								
马达连接	Motor wiring	U、V、W		螺钉端子 Screw terminal												
		电缆截面积mm² Cable sectional Aera mm²		1...2.5				2.5...6								
直流母线连接(制动电阻的连接)	DC bus connection (connection of braking resistor)	DC+、DC-、R		螺钉端子 Screw terminal												
		电缆截面积mm² Cable sectional Aera mm²		1...2.5				2.5...6								
PE连接		PE connection		外壳上的 M4螺钉				M4 screws on the housing								
最大马达电缆长度	Maximum motor cable length	屏蔽电缆 m Shielded cable m		50												
		非屏蔽电缆 m Unshielded cable m		100												
防护等级		Protection level		IP20												
外形尺寸		Dimensions		B1				B2								
大约重量 kg		Weight kg		1.7				2.8								

AX-PM26-B3C11	AX-PM26-B3C15	AX-PM26-B3C18	AX-PM26-B3C22	AX-PM26-B3C30	AX-PM26-B3C37	AX-PM26-B3C45	AX-PM26-B3C55	AX-PM26-B3C75	AX-PM26-B3C90	AX-PM26-B3D11	AX-PM26-B3D13
11	15	18.5	22	30	37	45	55	75	90	110	132
26	33	39	46	63	78	86	104	140	172	198	242
32	39	46	53	73	88	78	94	117	154	189	218
15.2	18.71	38	45	60	75	90	110	145	178	190	202
>0.95											
0.4		0.5	0.7	1	1.3		1.67	1.93	2.48	2.3	3.02
0.055				2x0.055		0.083		0.153			
<40				<50		<75					
1											
15											
螺钉端子 Screw terminal						电缆终端 Cable termination					
4...10			6...25			35...2x120					
螺钉端子 Screw terminal						电缆终端 Cable termination					
4...10			6...25			35...2x120					
螺钉端子 Screw terminal											
4...10			6...25			25...70					
外壳上的 M4螺钉 the housing			外壳上的 M5螺钉 the housing			电缆终端 Cable termination					
50											
100											
IP20											
B3		B4				B6					
7		16				65					

16 驱动器操作面板

16.1 操作面板概述

操作面板OP25为驱动器调试提供更加灵活的调试诊断方式，AX系列伺服驱动器可以通过PC及上位机进行调试，也可以使用OP25进行快捷调试。

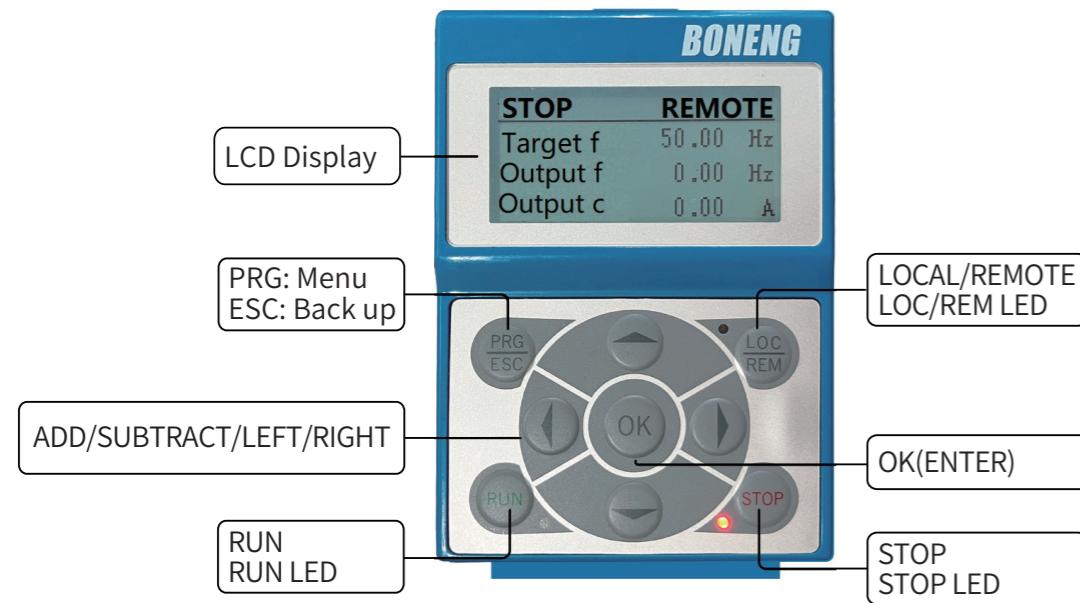

操作面板订货型号为：
A1-OP25

注：A1-OP25和AX-CM51-PN-PE匹配时，需要通过专用转接线来连接，请直接订购AD-OP25即可，既包含了操作键盘也包含了转接线。

16 Operation panel

16.1 General information

The AX-series drive can be debugged with either PC-Software(BonengDrivesoft) or Operation Panel(OP25). The operation Panel(OP25) can make drive debugging and diagnosis easier and more flexible.

The Operation Panel order number is: A1-OP25

Note: When A1-OP25 and AX-CM51-PN-PE are matched, they need to be connected through a dedicated adapter cable. Please order AD-OP25 directly, which includes both the operation keyboard and the adapter cable.

17 驱动器可选件

17.1 制动电阻

制动电阻用于使大转动惯量的负载迅速制动。在马达和负载制动时，动能转换成的再生电能会返回到驱动器中，直流母线电压因此抬高，驱动器将这些再生的能量几乎全部消耗在制动电阻上；400V 50/60Hz AX精准系列伺服驱动器可选的制动电阻推荐规格如下：

17 Options

17.1 Braking Resistor

The braking resistor is used to quickly brake the load with large moment of inertia. When the load and motor brake, the regenerative energy converted from kinetic energy will be returned to the driver, and then the DC bus voltage will be raised. The braking resistor is installed to consume almost all of this part of energy to keep the DC bus voltage level. The recommended model of optional Braking Resistor for 400V-50/60 Hz AX-series servo drives are as follows:

框架	驱动器		允许的最小 制动电阻	推荐值		博能型号	
	无内置滤波器型号	有内置滤波器型号		功率(W)	阻值(Ω)	订货号	等效制动电阻
	Power module		Minimum allowable resistance value for the brake resistor	Recommend value		BONENG Type	
Frame size	Article number without filter	Article number with filter		Power (W)	Resistance (Ω)	Article number	Equivalent brake resistor
B1	AX-PM26-B3A75-N	AX-PM26-B3A75-F	374 Ω	60	750	A1-H02-A06-K-D75	60W 750 Ω
	AX-PM26-B3B15-N	AX-PM26-B3B15-F	374 Ω	80	390	A1-H02-A08-K-D39	80W 390 Ω
	AX-PM26-B3B22-N	AX-PM26-B3B22-F	140 Ω	150	180	A1-H02-A15-K-D18	150W 180 Ω
	AX-PM26-B3B30-N	AX-PM26-B3B30-F	140 Ω	150	180	A1-H02-A15-K-D18	150W 180 Ω
B2	AX-PM26-B3B40-N	AX-PM26-B3B40-F	75 Ω	300	100	A1-H02-A30-K-D10	300W 100 Ω
	AX-PM26-B3B55-N	AX-PM26-B3B55-F	75 Ω	300	100	A1-H02-A30-K-D10	300W 100 Ω
	AX-PM26-B3B75-N	AX-PM26-B3B75-F	75 Ω	400	75	A1-H02-A40-K-C75	400W 75 Ω
B3	AX-PM26-B3C11-N	AX-PM26-B3C11-F	30 Ω	800	36	A1-H02-A80-K-C36	800W 36 Ω
	AX-PM26-B3C15-N	AX-PM26-B3C15-F	30 Ω	800	36	A1-H02-A80-K-C36	800W 36 Ω
B4	AX-PM26-B3C18-N	AX-PM26-B3C18-F	27 Ω	1000	27	A1-H02-B10-K-C27	1000W 27 Ω
	AX-PM26-B3C22-N	AX-PM26-B3C22-F	27 Ω	1000	27	A1-H02-B10-K-C27	1000W 27 Ω
	AX-PM26-B3C30-N	AX-PM26-B3C30-F	15 Ω	2000	15	A1-H02-B20-K-C15	2000W 15 Ω
	AX-PM26-B3C37-N	AX-PM26-B3C37-F	15 Ω	2000	15	A1-H02-B20-K-C15	2000W 15 Ω
B6	AX-PM26-B3C45-N	AX-PM26-B3C45-F	10 Ω	3000	10	A1-H02-B30-K-C10	3000W 10 Ω
	AX-PM26-B3C55-N	AX-PM26-B3C55-F	10 Ω	3000	10	A1-H02-B30-K-C10	3000W 10 Ω
	AX-PM26-B3C75-N	AX-PM26-B3C75-F	7.1 Ω	4000	7.5	A1-H02-B40-K-B75	4000W 7.5 Ω
	AX-PM26-B3C90-N	AX-PM26-B3C90-F	7.1 Ω	4000	7.5	A1-H02-B40-K-B75	4000W 7.5 Ω
	AX-PM26-B3D11-N	AX-PM26-B3D11-F	5 Ω	6000	5	A1-H02-B60-K-B50	6000W 5 Ω
	AX-PM26-B3D13-N	AX-PM26-B3D13-F	5 Ω	6000	5	A1-H02-B60-K-B50	6000W 5 Ω

17.2 进线电抗器

当系统的故障率高时，需要加装进线电抗器以保护驱动器不受过大的谐波电流的干扰，改善驱动器的输入侧功率因数；防止过载，并将进线谐波限制在允许的值内，以确保驱动器达到期望的使用寿命。400V 50/60Hz AX精准系列伺服驱动器可选的进线电抗器推荐型号如下表：

17.2 Incoming line reactors

A incoming line reactor is required and needful to prevent the drive from being disturbed by excessive harmonic currents, and improve the Input side power factor, when the system has a high failure rate. In addition, the incoming line reactor can limit the line harmonics to allowable values to ensure the drive's expected service life, when the overload occurs. The recommended model of optional incoming line reactors for 400V-50/60 Hz AX-series servo drives are listed below:

驱动器 Drives		进线电抗器 推荐参数 Recommended parameters of reactors		订货号 Order number
框架 Dimension types	无内置 滤波器 Without built-in filter 型号	额定 电流 (A) Rated current (A)	电感 (mH) (A) Rated inductance (A)	
B1	AX-PM26-B3A75-N	2.6	5.9	A1-H12-TB280
	AX-PM26-B3B15-N	4.9	3.1	A1-H12-TB280
	AX-PM26-B3B22-N	7.1	2.2	A1-H12-TB200
	AX-PM26-B3B30-N	9.2	1.7	A1-H12-TB140
B2	AX-PM26-B3B40-N	12.2	1.3	A1-H12-TA930
	AX-PM26-B3B55-N	15.8	1	A1-H12-TA700
	AX-PM26-B3B75-N	21.6	0.8	A1-H12-TA700
B3	AX-PM26-B3C11-N	31.2	0.5	A1-H12-TA470
	AX-PM26-B3C15-N	38.4	0.4	A1-H12-TA350
B4	AX-PM26-B3C18-N	45.6	0.5	A1-H12-TA280
	AX-PM26-B3C22-N	54	0.4	A1-H12-TA240
	AX-PM26-B3C30-N	72	0.3	A1-H12-TA160
	AX-PM26-B3C37-N	90	0.2	A1-H12-TA160
B6	AX-PM26-B3C45-N	120	0.117	A1-H12-TB120
	AX-PM26-B3C55-N	150	0.094	A1-H12-TA095
	AX-PM26-B3C75-N	200	0.07	A1-H12-TA070
	AX-PM26-B3C90-N	250	0.056	A1-H12-TA056
	AX-PM26-B3D11-N	250	0.056	A1-H12-TA056
	AX-PM26-B3D13-N	290	0.048	A1-H12-TA048

17.3 进线滤波器

进线滤波器的作用是抑制驱动器通过输入电源线所传输到公共电网中的电磁干扰,同时也衰减从电源线进入驱动器的干扰；在安装时请尽量靠近驱动器的输入端子侧进行安装，请使用驱动器专用的进线滤波器。400V 50/60Hz AX精准系列伺服驱动器可选的进线滤波器推荐型号如下表：

17.3 Incoming filter

The function of the incoming line filter is to suppress the electromagnetic interference transmitted from/to the drive to/from the public power supply network through the power supply line. When use it, please choose recommended drive specific line filter, and install it as close to the input end of the drive as possible. The recommended types of incoming line filter for 400V-50/60 Hz AX-series servo drives are as follows:

驱动器 Drives		EMC 滤波器 filter		订货号 Order number
框架 Dimension types	无内置 滤波器 Without built-in filter 型号	额定 电流 (A) Rated current (A)	EMC 滤波器 filter	
B1	AX-PM26-B3A75-N	2.9		A1-H11-A-C10
	AX-PM26-B3B15-N	5.5		A1-H11-A-C10
	AX-PM26-B3B22-N	7.7		A1-H11-A-C10
	AX-PM26-B3B30-N	10.1		A1-H11-A-C10
B2	AX-PM26-B3B40-N	13.3		A1-H11-A-C20
	AX-PM26-B3B55-N	17.2		A1-H11-A-C20
	AX-PM26-B3B75-N	22.2		A1-H11-A-C30
B3	AX-PM26-B3C11-N	32.6		A1-H11-A-C36
	AX-PM26-B3C15-N	39.9		A1-H11-A-C50
B4	AX-PM26-B3C18-N	36		A1-H11-A-C50
	AX-PM26-B3C22-N	42		A1-H11-A-C50
	AX-PM26-B3C30-N	57		A1-H11-A-C65
	AX-PM26-B3C37-N	70		A1-H11-A-C80
B6	AX-PM26-B3C45-N	100		A1-H11-A-D10
	AX-PM26-B3C55-N	130		A1-H11-A-D13
	AX-PM26-B3C75-N	150		A1-H11-A-D15
	AX-PM26-B3C90-N	180		A1-H11-A-D18
	AX-PM26-B3D11-N	200		A1-H11-A-D20
	AX-PM26-B3D13-N	250		A1-H11-A-D25

17.4 出线电抗器

当驱动器和马达之间的距离超过50米时，由于长电缆对地的寄生电容效应导致漏电流过大，驱动器容易频繁发生过流保护，同时为了避免马达绝缘损坏，须加输出电抗器补偿，输出电抗器可以减小马达绕组上的电压负载，以及采用长的马达电缆时，容性充放电电流加在功率部分的附加负载。400V 50/60Hz AX精准系列伺服驱动器可选的输出电抗器推荐型号如下表：

17.4 Outlet reactor

When the motor is more than 50m away from the drive, due to the parasitic capacitance effect of the long cable to the ground, the leakage current will become too large to trigger the over-current fault to protect the drive. To avoid this case and prevent motors from being damaged, a outlet reactor can be used. Because the outlet reactor can reduce the voltage applied to the motor windings and the additional load that capacitive charge/discharge current added to the power module when long cable used. The recommended model of optional Outlet Reactor for 400V-50/60 Hz AX-series servo drives are as follows:

驱动器 Drives		进线电抗器 推荐参数		Recommended parameters of reactors	订货 Order 号 number
框架 Dimension types	无内置 滤波器 型号 built-in filter	额定 电流 (A)	Rated current (A)	电感 (mH) Rated inductance (A)	
B1	AX-PM26-B3A75-N	2.6		3.2	A1-H13-TB140
	AX-PM26-B3B15-N	4.9		1.7	A1-H13-TB140
	AX-PM26-B3B22-N	7.1		1.2	A1-H13-TB100
	AX-PM26-B3B30-N	9.2		0.9	A1-H13-TA700
B2	AX-PM26-B3B40-N	12.2		0.7	A1-H13-TA470
	AX-PM26-B3B55-N	15.8		0.5	A1-H13-TA350
	AX-PM26-B3B75-N	21.6		0.4	A1-H13-TA230
B3	AX-PM26-B3C11-N	31.2		0.3	A1-H13-TA180
	AX-PM26-B3C15-N	38.4		0.2	A1-H13-TA180
B4	AX-PM26-B3C18-N	45.6		0.2	A1-H13-TA140
	AX-PM26-B3C22-N	54		0.2	A1-H13-TA120
	AX-PM26-B3C30-N	72		0.1	A1-H13-TA087
	AX-PM26-B3C37-N	90		0.1	A1-H13-TA078
B6	AX-PM26-B3C45-N	120		0.058	A1-H13-TA058
	AX-PM26-B3C55-N	150		0.047	A1-H13-TA047
	AX-PM26-B3C75-N	200		0.035	A1-H13-TA035
	AX-PM26-B3C90-N	250		0.028	A1-H13-TA028
	AX-PM26-B3D11-N	250		0.028	A1-H13-TA028
	AX-PM26-B3D13-N	290		0.024	A1-H13-TA024

随着技术迭代进步，博能产品样本将会同步更新，请见谅。
Along with the technology advancedet.,the product of
the manual of Boneng will be changed,please forgive.

控制层 CONTROL

驱动层 DRIVE

马达层 MOTOR

齿轮层 GEAR



X3010 PLC

EtherCAT&Modbus
24VDC



X3050 运动控制器
Motion Controller

EtherCAT&Modbus
24VDC

C/F/K/S-M
* . . . D
马达分布式
变频驱动器
Integrated
Gearmotor
Drive

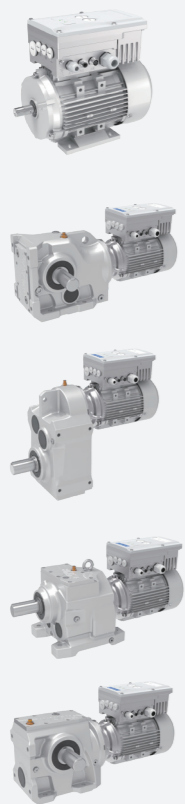

EtherCAT &
Modbus
380~480VAC
0.25~3kW
i=4~355

AM 变频驱动器
Variable Frequency Drive



Modbus
380~480VAC
0.75~5.5kW

A1 变频驱动器
Variable Frequency Drive



Modbus/CANopen
/PROFINET
380~480VAC
0.75~250kW

C/F/K/S/R
齿轮马达
Gearmotor



380~480VAC
0.09~200kW
i=1.25~500

MP/MU/MA
三相交流异步马达
Asynchronous Motor



380~480VAC
0.09~90kW
960/1450r/min
1160/1750r/min

HB/BE/HK
齿轮箱
Gearbox



4.2~15775kW
i=5.6~450

P/PK
行星齿轮箱
Planetary
Gearbox



0.4~14000kW
i=25~4000

PW
卷扬齿轮箱
Planetary
Winch
Gearbox

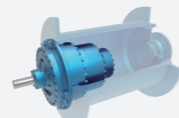

1~1810kW
i=13~940

PS
回转齿轮箱
Planetary
Slewing
Gearbox



1~1626kW
i=14~947

J/JB
升降机
Jack



0.35~22.63kW
i=5~34

T
转向箱
Spiral Bevel
Gearbox



0.08~303kW
i=1:1~3:1

MX&AX
伺服马达&伺
服驱动器
Permanent
Magnet
Servo Motor
& Servo Drive



EtherCAT/
PROFINET
380~480VAC
0.28~14kW
1500/2000r/min
3000/4500r/min

C/F/K/S-MX
&AX齿轮伺
服马达&伺
服驱动器
Servo
Gearmotor
& Servo Drive

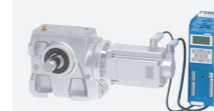
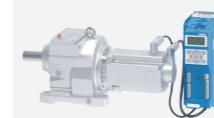
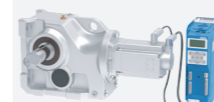

EtherCAT/
PROFINET
380~480VAC
0.28~14kW
i=1.25~315

PX-MX&AX
行星伺服马达
&伺服驱动器
Planetary
Precision Gear
Servo Motor
& Servo Drive



EtherCAT/
PROFINET
380~480VAC
0.38~14kW
i=3~100

PN-MN&AN
行星伺服马达
&伺服驱动器
Planetary
Precision Gear
Servo Motor
& Servo Drive



EtherCAT
PROFINET
380~480VAC
0.28~5.03kW
i=3~100

ME&AN
永磁同步伺服马
达&伺服驱动器
Permanent
Magnet
Servo Motor
& Servo Drive



EtherCAT/
PROFINET
200~240VAC
0.1kW~1.2kW

博能传动(沈阳)有限公司	BONENG TRANSMISSION(SHENYANG)CO.,LTD.
辽宁省沈阳市沈北新区 太平洋工业城A区A73-6号 电话: 024-31271571	No. A73-6, Area A, Pacific Industrial City, Shenbei New District, Shenyang, Liaoning Province, China TEL: 024-31271571

博能传动(天津)有限公司	BONENG TRANSMISSION(TIANJIN)CO.,LTD.
天津市北辰区双海道6号 宏鹏工业园7号车间 电话: 022-26929556	7th Workshop, Hongpeng Industrial Park, No. 6 Shuanghai Road, Beichen District, Tianjin City,China TEL: 022-26929556

博能传动(潍坊)有限公司	BONENG TRANSMISSION(WEIFANG)CO.,LTD.
山东省潍坊市安丘市经济开发区 汶水路与昆仑大街交叉口往北 100米路东1号车间 电话: 0536-2141166	1st Workshop, Economic Development Zone, Anqiu, Weifang City, Shandong Province, China TEL: 0536-2141166

博能传动(开封)有限公司	BONENG TRANSMISSION(KAIFENG)CO.,LTD.
河南省开封市宋城路四大街11号 海神机械院内五号厂房 电话: 0371-23335238	5th Workshop, Haishen Machinery, No.11, Fourth Street, Songcheng Road,New District, Kaifeng City, Henan Province, China TEL: 0371-23335238

博能传动(长沙)有限公司	BONENG TRANSMISSION(CHANGSHA)CO.,LTD.
湖南省长沙市望城经济开发区 普瑞大道1288号 电话: 0731-88386958	No. 1288 Puri Avenue, Wangcheng Economic Development Zone, Changsha City, Hunan Province, China TEL: 0731-88386958

博能传动设备(成都)有限公司	BONENG TRANSMISSION EQUIPMENT(CHENGDU) CO., LTD.
四川省成都市金牛区金牛坝路9号5栋 向荣中心A座7楼-703 电话: 028-87741100	703, 7th Floor, Block A, Xiangrong Center, Building 5, No. 9 Jinniuba Road, Jinniu District, Chengdu City, Sichuan Province, China TEL: 028-87741100

博能传动(肇庆)有限公司	BONENG TRANSMISSION(ZHAOQING)CO.,LTD.
广东省肇庆市鼎湖区肇庆新区 科创大道7号平谦国际现代产业园 一期A12北厂房 电话: 0757-86719757	No. 7 Science and Technology Innovation Avenue, Zhaoqing New Area, Dinghu District, Zhaoqing City, Guangdong Province, China TEL: 0757-86719757

博能传动(苏州)有限公司	BONENG TRANSMISSION(SUZHOU)CO.,LTD.
江苏省苏州市相城区如元路100号 电话: 0512-66189662	No. 100, Ruyuan Road, Xiangcheng District, Suzhou, Jiangsu Province, China TEL: 0512-66189662

博能传动(美国)有限公司	BONENG TRANSMISSION(USA)LLC.
1250 E 222nd Euclid, OH 44117, United Staes TEL: 1-216-618-0138 TEL: 1-216-618-0496 TEL: 1-216-618-3099	1250 E 222nd Euclid, OH 44117, United Staes TEL: 1-216-618-0138 TEL: 1-216-618-0496 TEL: 1-216-618-3099

博能传动(印度)有限公司	BONENG TRANSMISSION(INDIA)PVT.LTD
Plot No. E-10/3, MIDC sinnar (Malegaon) Industrial Area, Nashik, 422123, Maharashtra, India. TEL:+91-11- 4507 6293 (DELHI) TEL:+91-22-2781 3385 (MUMBAI)	Plot No. E-10/3, MIDC sinnar (Malegaon) Industrial Area, Nashik, 422123, Maharashtra, India. TEL:+91-11- 4507 6293 (DELHI) TEL:+91-22-2781 3385 (MUMBAI)